

SIEMENS

SINUMERIK 840D/ SIMODRIVE 611digital SINUMERIK Safety Integrated

Description of Functions

Valid for

Control

SINUMERIK 840D powerline/840 DE powerline

Drive

SIMODRIVE 611 digital

Software release

NC	6.5
NC	7.1
NC	7.2

03.06 Edition

Regulations and Standards	1
Brief Description	2
System Features	3
Basic Procedures and Mechanisms	4
Safety-Related Functions	5
Data Descriptions	6
Commissioning	7
Diagnostics	8
Interaction with Other Functions	9
Engineering and Application Examples	10
Appendix	A
Index	I

SINUMERIK® documentation

Printing history

Brief details of this edition and previous editions are listed below.

The status of each edition is shown by the code in the "Remarks" column.

Status code in the "Remarks" column:

A New documentation.

B Unrevised reprint with new Order No.

C Revised edition with new status.

If factual changes have been made on the page since the last edition, this is indicated by a new edition coding in the header on that page.

Edition	Order No.	Remarks
04.96	6FC5 297-0AB80-0BP0	A
08.97	6FC5 297-0AB80-0BP1	C
04.99	6FC5 297-5AB80-0BP0	C
05.00	6FC5 297-5AB80-0BP0	C
07.02	6FC5 297-6AB80-0BP1	C
11.03	6FC5 297-6AB80-0BP2	C
10.04	6FC5 297-7AB80-0BP0	C
03.06	6FC5 297-7AB80-0BP1	C

Trademarks

All product designations could be trademarks or product names of Siemens AG or other companies which, if used by third parties, could infringe the rights of their owners.

We have checked that the contents of this document correspond to the hardware and software described. Nevertheless, differences might exist and therefore we cannot guarantee that they are completely identical. However, the information contained in this document is reviewed regularly and any necessary changes included in subsequent editions. We welcome suggestions for improvement.

Foreword

Structure of the documentation

The SINUMERIK documentation is organized in 3 parts:

- General Documentation
- User Documentation
- Manufacturer/Service Documentation

More detailed information about other SINUMERIK 840D/810D documents and publications for all SINUMERIK controllers (e.g. universal interface, measuring cycles, etc.) can be obtained from your local SIEMENS representative.

An overview of publications, which is updated on a monthly and also provides information about the language versions available, can be found on the Internet at: <http://www.siemens.com/motioncontrol>

Follow menu items "Support" → "Technical Documentation" → "Overview of Documentation".

Target audience

This documentation is intended for manufacturers/end users of machine tools and production machines who use SINUMERIK 840D and SIMODRIVE 611digital and the integrated safety functions (SINUMERIK Safety Integrated[®]).

Standard scope

This documentation only describes the functionality of the standard version. Extensions or changes made by the machine tool manufacturer are documented by the machine tool manufacturer.

It may be possible to run functions that are not described in this document in your controller. This does not, however, represent an obligation to supply such functions with a new control or when servicing.

Hotline

If you have any questions, please get in touch with our Hotline:

A&D Technical Support

Tel.: +49 (0) 180 / 5050 – 222

Fax: +49 (0) 180 / 5050 – 223

E-mail: <mailto:adsupport@siemens.com>

Internet: <http://www.siemens.com/automation/support-request>

Please send any questions about the documentation (suggestions for improvement, corrections) to the following fax number or e-mail address:

Fax: +49 (0) 9131 / 98–63315

Fax form: Refer to the reply form at the end of the document

E-mail: mailto:motioncontrol.docu@siemens.com

Internet address

<http://www.siemens.com/motioncontrol>

Objectives

This Description of Functions provides all of the information regarding the safety functions integrated in the SINUMERIK 840D and SIMODRIVE 611 digital that are relevant for start-up (commissioning) and configuration.

Standard scope

The main areas covered by this Description of Functions are as follows:

- Regulations and Standards
- Short description
- System features
- Basic procedures and mechanisms
- Description of safety functions
- Lists and description of all of the signals and data
- Start-up (commissioning)
- Diagnostics
- Interaction with other functions
- Engineering and application examples

Separate documents are available for user-oriented activities. These include, for example, generating part programs and handling controls.

Separate information is also available for operations that the machine tool manufacturer must carry-out. These include, for example, configuring/engineering, installation and programming the PLC.

Notes on how to use this manual

The following reference guides are provided in this Description of Functions:

- Overall table of contents
- Appendix with abbreviations and references, glossary
- Index

If you require information about a certain term, please look in the Appendix for the specific Chapter Index for the particular term. Both the chapter number and the page number are listed where you will find this particular information.

Documentation, 07/02 Edition

Note

The documentation Edition 07/02 describes the scope of functions for the following products and software release:

SINUMERIK 840D with software release 6.3.21
SIMODRIVE 611digital with software release 5.1.14

When compared to the 03/01 Edition, in the 07/02 Edition, the main functions for SINUMERIK 840D/611digital have been added:

Cons. No.	New functions in SINUMERIK 840D/611digital
1	NCU onboard I/Os (Chapter 3)
2	Internal NC pulse cancellation (Chapter 3)
3	SPL block, brake test, safe brake test (Chapter 8)
4	Disable SPL block (software relay) (Chapter 3)
5	Improved diagnostics (Chapter 5)
6	PROFIsafe (Chapter 3)

Documentation, 11/03 Edition

Note

The documentation Edition 11/03 describes the functionality for the following products and software release:

SINUMERIK 840D with software release 6.4

When compared to the 07/02 Edition, in the 11/03 Edition, the main functions for SINUMERIK 840D/611digital have been added:

Cons. No.	New functions in SINUMERIK 840D/611digital
1	ProgEvent (Chapter 3.10.10)
2	STOP E (Chapter 3)
3	Acceptance test support (Chapter 5.4)
4	Drive bus failure (Chapter 3.13)

Documentation, 10/04 Edition

Note

The documentation Edition 10/04 describes the functionality for the following products and software release:

SINUMERIK 840D with software release 6.4, 6.5, 7.1, 7.2

When compared to the 11/03 Edition, in the 10/04 Edition, the main functions for SINUMERIK 840D/611digital have been added:

Cons. No.	New functions in SINUMERIK 840D/611digital
1	Setpoint changeover (from SW 7.2) (Chapter 9.2)
2	Deleting the external SPL outputs for SPL system faults (from SW 6.5) Chapter 3.10
3	PROFIsafe net (useful) data expansion filtering (Chapter 3.12)

Documentation, 03/06 Edition

Note

The documentation 03/06 Edition describes the scope of functions for the following products and software release:

SINUMERIK 840D with software release 6.5, 7.1, 7.2

When compared to the 10/04 Edition, in the 03/06 Edition, the main functions for SINUMERIK 840D/611digital have been added:

Cons. No.	New functions in SINUMERIK 840D/611digital
1	Certification acc. to IEC 61508, NFPA 79–2002 (Chapters 1.2.6, 1.3.3) NRTL Listing (Chapter 1.3.2)

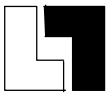

Supplement to ordering data

In this documentation you will find the symbol shown on the left with a reference to an ordering data option. The function described will only be able to be used if the control contains the designated option.

Safety Instructions

This Manual contains information which you should carefully observe to ensure your own personal safety and the prevention of material damage. The notices referring to your personal safety are highlighted by a safety alert symbol. The notices referring to property damage alone have no safety alert symbol. The warnings appear in decreasing order of risk as given below.



Danger

Indicates that death or severe personal injury **will** result if proper precautions are not taken.



Warning

Indicates that death or severe personal injury **can** result if proper precautions are not taken.



Caution

With a warning triangle indicates that minor personal injury can result if proper precautions are not taken.

Caution

Without warning triangle indicates that material damage can result if proper precautions are not taken.

Notice

Indicates that an undesirable event or state may arise if the relevant notes are not observed.

If several hazards of different degrees occur, the hazard with the highest degree must always be given priority. If a warning note with a warning triangle warns of personal injury, the same warning note can also contain a warning of material damage.

Qualified personnel

The associated device/system may only be set up and operated using this documentation. Commissioning and operation of a device/system may only be performed by **qualified personnel**. Qualified persons are defined as persons who are authorized to commission, to ground, and to tag circuits, equipment, and systems in accordance with established safety practices and standards.

Correct use

Please note the following:



Warning

The equipment may only be used for single purpose applications explicitly described in the catalog and in the technical description and it may only be used along with third-party devices and components recommended by Siemens. To ensure trouble-free and safe operation of the product, it must be transported, stored and installed as intended and maintained and operated with care.

PRÜFZERT symbol

The safety functions that are available under the "SINUMERIK Safety Integrated" name with the SINUMERIK 840D/DE powerline system have been certified by several institutes.

When ordering the "SINUMERIK Safety Integrated" option, in addition to the Certificate of License included with the product, four different adhesive labels are also provided.

1. PRÜFZERT symbol for certification acc. to EN 954–1/VDE 801



Symbol of the BGIA
[BG Institute for
Occupational Safety
and Health]

If the SINUMERIK 840D powerline system is used in Europe, this PRÜFZERT symbol can be used. Standards EN 954–1 and DIN V VDE 0801 were the basis for the testing.

The associated certificate is valid for software releases up to and including 6.5.

2. PRÜFZERT symbol for certification acc. to EN 954–1/IEC 61508



Symbol of the BGIA
[BG Institute for
Occupational Safety
and Health]

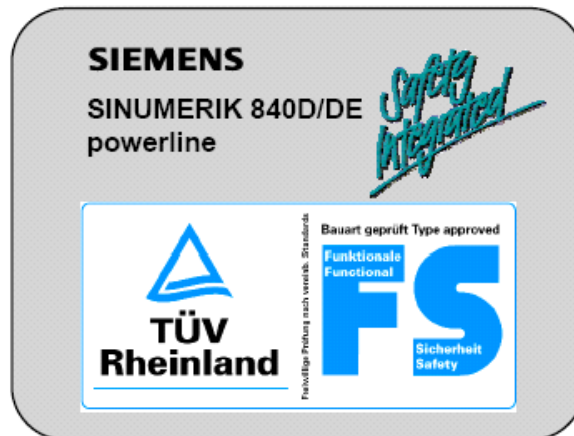

Symbol of TÜV Rheinland

If the SINUMERIK 840D powerline system is used worldwide, then one of these PRÜFZERT symbols can be used.

The safety functions fulfill the requirements of Category 3 acc. to EN 954–1 and SIL 2 (Safety Integrity Level) according to IEC 61508.

If the SINUMERIK 840D/DE powerline system with the SINUMERIK Safety Integrated safety functions is to be operated, making reference to the associated certificate, then certain additional limitations and constraints must be carefully observed (refer to Chapter 3.6).

The certificate according to EN 954–1/IEC 61508 is valid from software release 6.4.15 onwards.

3. PRÜFZERT symbol for the certificate according to NFPA 79–2002 and NRTL listing



Symbol of the TÜV Rheinland of North America



In order to increase the level of acceptance in the US, the system was also tested by an NRTL (Nationally Recognized Testing Laboratory) corresponding to the requirements of NFPA 79–2002. The basis for this is certification according to IEC 61508. If the SINUMERIK 840D/DE powerline system with the SINUMERIK Safety Integrated safety functions is to be operated, making reference to this NRTL listing, certain, additional limitations and constraints must be carefully observed (refer to Chapter 3.6).

The certificate according to EN 954–1/IEC 61508 is valid from software release 6.4.15 onwards.

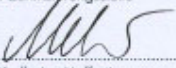

Test certificates

The attachments to the following test certificates with the certified software and hardware releases are not included in this documentation. If you require the appropriate attachments, then please use the address specified in the corrections/suggestions sheet (last page).

Type test certificate of the BGIA according to EN 954-1/VDE 0801

Prüf- und Zertifizierungsstelle im BG-PRÜFZERT		 BIA Berufsgenossenschaftliches Institut für Arbeitsschutz Hauptverband der gewerblichen Berufsgenossenschaften	
Baumusterprüfbescheinigung		0306004	
		Bescheinigungs-Nummer	
Name und Anschrift des Bescheinigungsinhabers: (Auftraggeber)	Siemens AG, A&D MC RD12 Frauenauracher Straße 80, 91056 Erlangen		
Name und Anschrift des Herstellers:	Siemens AG, A&D MC RD12 Frauenauracher Straße 80 91056 Erlangen		
Zeichen des Auftraggebers: A&D MC RD12	Zeichen der Prüf- und Zertifizierungsstelle: 2001 21145-10 Met/Apf/NKtr	Ausstellungsdatum: 26.07.2004	
Produktbezeichnung:	Sicherheits-Antriebssteuerung für Maschinen		
Typ:	SINUMERIK 840 D und 840 DE safety integrated mit SIMODRIVE 611 D safety integrated Nähere Angaben zu Hard- und Softwareständen siehe Anlage.		
Bestimmungsgemäße Verwendung:	Realisierung sicherer Maschinenfunktionen: Halt, Betriebshalt, reduzierte Geschwindigkeit, begrenzte Absolutlage, Ein-/Ausgangssignale, programmierbare Logik, Bremsrampe, Bremsentest, Profi Safe-Host		
Prüfgrundlage:	[1] DIN V VDE 0801; 01/90 [2] DIN V VDE 0801/A1; 10/94 [3] EN 954-1; 03/97 [4] EN 60204-1; 1998 [5] IEC-Arbeitspapier 22G/21/CDV, 1995-04-14 EMC product standard including specific methods for power drive systems		
Zugehöriges Prüfzeugnis:	2001 21145-10		
Bemerkungen:	Gültig für Steuerungen mit den in der Anlage näher bezeichneten Versionsständen. Steuerung entspricht Anforderungsklasse 4 nach DIN V VDE801 und Kategorie 3 nach EN 954-1:1996 mit Ausnahme des Bremsentests, der Kategorie 2 nach EN 954-1:1996 erfüllt.		
Das geprüfte Baumuster entspricht den einschlägigen Bestimmungen der Richtlinie 98/37/EG (Maschinen). Weitere Bedingungen regelt die Prüf- und Zertifizierungsordnung vom April 2004.			
Leiter der Zertifizierungsstelle	Fachzertifizierer		
 (i.V. Dr. Karlheinz Meffert)	 (Dipl.-Ing. Ralf Apfeld)		
PZB100 05.04 	Postadresse: 53754 Sankt Augustin	Hausadresse: Alte Heerstraße 111 53757 Sankt Augustin	Telefon: 0 22 41/2 31-02 Telefax: 0 22 41/2 31-22 34

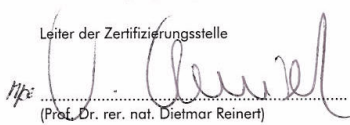
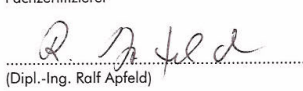
Type test certificate of the BGIA according to EN 954-1/IEC 61508

Prüf- und Zertifizierungsstelle im BG-PRÜFZERT		 BGIA Berufsgenossenschaftliches Institut für Arbeitsschutz Hauptverband der gewerblichen Berufsgenossenschaften	
Baumusterprüfbescheinigung			
			0406008
Bescheinigungs-Nummer			
Name und Anschrift des Bescheinigungsinhabers: (Auftraggeber)	Siemens AG, A&D MC RD12 Frauenauracher Straße 80, 91056 Erlangen		
Name und Anschrift des Herstellers:	Siemens AG, A&D MC RD12 Frauenauracher Straße 80, 91056 Erlangen		
Zeichen des Auftraggebers: A&D MC RD12	Zeichen der Prüf- und Zertifizierungsstelle: 2005 20724-05 Rt/Apf/MKr	Ausstellungsdatum: 27.07.2005	
Produktbezeichnung:	Antriebssteuerung für Maschinen mit Sicherheitsfunktionen		
Typ:	SINUMERIK Safety Integrated mit SINUMERIK 840D powerline / SINUMERIK 840DE powerline mit SIMODRIVE 611 digital, genaue Bezeichnung der Hard- und Softwarestände siehe Anlage		
Bestimmungsgemäße Verwendung:	Maschinensteuerung mit integrierten Sicherheitsfunktionen für die Realisierung der sicheren Maschinenfunktionen Halt, Betriebshalt, reduzierte Geschwindigkeit, „n<nx“, Software Endschalter, Software Nocken, Stops A-E und Bremsrampe. Ebenso sind in sicherer Technik die Funktionen Ein-/Ausgangssignale (einschließlich Bremsenansteuerung), PROFIsafe-Master, programmierbare Logik und Bremsentest realisiert.		
Prüfgrundlage:	[1] DIN EN 61508, Teil 1 - 7:2002/2003 (soweit zutreffend) [2] DIN EN 954-1:1997-03 [3] DIN EN 61800-5-1:2003-09 [4] DIN EN 61800-3:2005-07 [5] DIN EN 50178:1998-04 [6] DIN EN 60204-1:1998-11		
Zugehöriges Prüfzeugnis:	2004 22769-01 vom 27.07.2005		
Bemerkungen:	Die Sicherheitsfunktionen erfüllen die grundsätzlichen Sicherheitsanforderungen der DIN EN 61508 für den Einsatz bis einschließlich SIL2 in der Betriebsart mit hoher Anforderungsrate und die Kategorie 3 nach DIN EN 954-1 mit Ausnahme der Funktionalität des Bremsentests, für die Kategorie 2 nach DIN EN 954-1 erfüllt ist. Diese Baumusterprüfbescheinigung ersetzt die Baumusterprüfbescheinigung mit gleicher Nummer vom 08.09.2004.		
Das geprüfte Baumuster entspricht den einschlägigen Bestimmungen der Richtlinie 98/37/EG (Maschinen).			
Weitere Bedingungen regelt die Prüf- und Zertifizierungsordnung vom April 2004.			
Leiter der Zertifizierungsstelle	Fachzertifizierer		
 /s: (Prof. Dr. rer. nat. Dietmar Reinert)	 (Dipl.-Ing. Ralf Apfeld)		
PZB10D 01.05	 Postadresse: 53754 Sankt Augustin	Hausadresse: Alte Heerstraße 111 53757 Sankt Augustin	Telefon: 0 22 41/2 31-02 Telefax: 0 22 41/2 31-22 34

Certificate of TÜV Rheinland



TÜV TÜV Rheinland Group

TÜV Industrie Service GmbH
Automation, Software und Informationstechnologie

ZERTIFIKAT

CERTIFICATE

Nr./No. 968/EZ 182.01/05

Prüfgegenstand Product tested	SINUMERIK Safety Integrated drive control	Zertifikatsinhaber Licence holder	Siemens AG, A&D MC Frauenauracher Straße 80 D-91056 Erlangen Germany
		Hersteller Manufacturer	See Licence holder
Typbezeichnung Type designation	SINUMERIK Safety Integrated, consisting of SINUMERIK 840D/DE powerline, SIMODRIVE 611digital. See test report for more detailed product information	Verwendungszweck Intended application	Machine control for Safety functions: Standstill, Operating stop, Reduced speed, Safe software limit switches, Safe software cams, Safety related I/O (including brake control), Programmable logic, Braking ramp, PROFIsafe-Master, Safe defined output signal (n<nx), Safe stops (Stops A-E)
Prüfgrundlagen Codes and standards forming the basis of testing	IEC 61508, Part 1 - 7:2000 EN 954-1:1996 EN 60204-1:1997 EN 61800-5-1:2003 DIN EN 61800-3:2001 EN 50178:1997 NFPA 79:2002		
Prüfungsergebnis Test results	The system is suitable for safety related applications up to SIL 2 (IEC 61508) and CAT 3 (EN 954-1) under consideration of the information provided in the "Description of Functions".		
Besondere Bedingungen Specific requirements	-		



Der Prüfbericht-Nr. 968/EZ 182.01/05 vom 2005-08-29 ist Bestandteil dieses Zertifikates.

Der Inhaber eines für den Prüfgegenstand gültigen Genehmigungs-Ausweises ist berechtigt, die mit dem Prüfgegenstand übereinstimmenden Erzeugnisse mit dem abgebildeten Prüfzeichen zu versehen.

The test report-no. 968/EZ 182.01/05 dated 2005-08-29 is an integral part of this certificate.

The holder of a valid licence certificate for the product tested is authorised to affix the test mark shown opposite to products which are identical with the product tested.

TÜV Industrie Service GmbH
Geschäftsfeld ASI
Automation, Software und Informationstechnologie
Am Grauen Stein, 51105 Köln
Postfach 91 09 51, 51101 Köln

2005-08-29
Datum/Date



Firmenstempel/Company seal





Unterschrift/Signature

10102 00 - 04/04 - 02/03

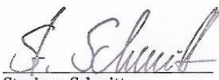
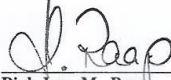
Certificate of TÜV Rheinland of North America

<h1>Certificate</h1>		
Certificate no. CU 72052622 01		
License Holder: Siemens AG, A&D MC Frauenauracher Str. 80 91056 Erlangen Germany		Manufacturing Plant: Siemens AG, A&D MC Frauenauracher Str. 80 91056 Erlangen Germany
Test report no.: USA-GG 30472653 002		Client Reference: Dietmar Wanner
Tested to: UL 508:1999 R12.03 UL 508C R7.03 NFPA 79:2002 CAN/CSA C22.2 No. 14-95 see also additional page[s]		
Certified Product: Ind. Ctrl. Equip. for Safety-related Functions License Fee - Units		
Listing Category: Industrial Control Equipment for Safety-Related Functions and E-Stop (per NFPA 79):		
Model Designation: SINUMERIK Safety Integrated Drive Control, consisting of: SINUMERIK 840D powerline or SINUMERIK 840DE powerline and SIMODRIVE 611 digital		
Rated Voltage: 3 AC 480V, 60Hz		
Rated Power: 3.7kW to 156kW		
Protection Class: I		
Appendix: 1		contd. on page 2
Licensed Test mark:	Signatures	Date of Issue (day/mo/yr)
	 Stephan Schmitt President	19/10/2005
	 Dipl.-Ing. M. Raap QA Certification Officer	
<small>TUV Rheinland of North America, Inc., 12 Commerce Road, Newtown, CT 06470, Tel (203) 426-0888 Fax (203) 426-4009</small>		

Certificate of TÜV Rheinland of North America

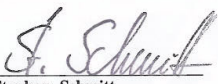
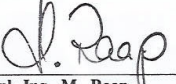
<h1>Certificate</h1>		
Certificate no. CU 72052622 02		
License Holder: Siemens AG, A&D MC Fraunauracher Str. 80 91056 Erlangen Germany	Manufacturing Plant: SIEMENS AG Elektronikwerk Amberg Werner-von-Siemens-Strasse 50 92224 Amberg Germany	
Test report no.: USA-GG 30472653 002	Client Reference: Dietmar Wanner	
Tested to: IEC 61508-1:1998 IEC 61508-2:2000 IEC 61508-3:1998 see also previous page[s]		
Certified Product: Ind. Ctrl. Equip. for Safety-related Functions License Fee - Units contd. from page 1		
Additional Manufacturing Plant: see above (K751531)		
Special Remarks: To be installed according to the licensee's installation instructions. Replaces Certificate CU72042952.		
Licensed Test mark: 	Signatures  Stephan Schmitt President	Date of Issue (day/mo/yr) 19/10/2005  Dipl.-Ing. M. Raap QA Certification Officer
<small>TUV Rheinland of North America, Inc., 12 Commerce Road, Newtown, CT 06470, Tel (203) 426-0888 Fax (203) 426-4009</small>		

Page 2/2

Table of Contents

1	Regulations and Standards	1-25
1.1	General information	1-25
1.1.1	Objectives	1-25
1.1.2	Functional safety	1-26
1.2	Safety of machinery in Europe	1-27
1.2.1	Machinery Directive (98/37/EC)	1-27
1.2.2	Harmonized European Standards	1-28
1.2.3	Standards to implement safety-related programmable electronic controls	1-30
1.2.4	pr EN/ISO 13849-1 (revision from EN 954-1)	1-31
1.2.5	EN IEC 62061	1-32
1.2.6	DIN EN 61508 (VDE 0803) or IEC 61508	1-34
1.2.7	Risk analysis/assessment	1-35
1.2.8	Risk reduction	1-37
1.2.9	Residual risk	1-37
1.3	Machine safety in the US	1-38
1.3.1	Minimum requirements of the OSHA	1-38
1.3.2	NRTL Listing	1-39
1.3.3	NFPA 79	1-39
1.3.4	ANSI B11	1-40
1.4	Machine safety in Japan	1-41
1.5	Equipment regulations	1-41
1.6	Other safety-related subjects and issues	1-42
1.6.1	Information sheets from the various regulatory bodies	1-42
1.6.2	Safety Integrated System Manual	1-42
2	Short Description	2-43
2.1	Control/drive system	2-43
2.2	SI system structure and basic features	2-45
2.3	Overview, SI functions	2-47
3	System Features	3-49
3.1	Certification	3-49
3.1.1	Certification acc. to EN 954-1/VDE 801	3-49
3.1.2	Certification acc. to EN 954-1/IEC 61508	3-50
3.1.3	NRTL Listing/NFPA 79-2002	3-50
3.2	Fault analysis	3-51
3.2.1	Monitoring functions	3-51
3.2.2	Fault analysis	3-51
3.3	Probability of failure	3-52
3.3.1	Subsystem "SINUMERIK 840D/ SIMODRIVE 611digital"	3-52
3.3.2	Subsystem "fail-safe PROFIsafe I/O"	3-54
3.3.3	Subsystem "Standard SIMATIC/SINUMERIK I/O"	3-55
3.4	Residual risks	3-56

3.5	System prerequisites	3-58
3.5.1	General prerequisites	3-58
3.6	Limitations/restrictions (IEC 61508, NFPA 79–2002, NRTL)	3-62
3.6.1	SINUMERIK 840D NCU – software release	3-62
3.6.2	SINUMERIK 840D NCU – modules	3-62
3.6.3	SIMODRIVE 611digital – control modules	3-62
3.6.4	PROFIsafe I/O	3-63
3.6.5	SINUMERIK I/O	3-63
3.6.6	Standard SIMATIC I/O	3-64
3.6.7	24 V power supplies that are permitted	3-66
3.6.8	Additional limitations/restrictions in order to fulfill NFPA 79–2002	3-67
4	Basic Procedures and Mechanisms	4-69
4.1	Monitoring clock cycle	4-69
4.2	Crosswise data comparison	4-70
4.3	Forced checking procedure	4-71
4.4	Actual value conditioning	4-73
4.4.1	Encoder types	4-73
4.4.2	Encoder adjustment, calibrating the axes	4-75
4.4.3	User agreement	4-76
4.4.4	Axis states	4-78
4.4.5	Overview of the data for mounting encoders	4-81
4.4.6	Taking into account selector gearboxes	4-82
4.4.7	Actual value synchronization (slip for 2–encoder systems)	4-84
4.4.8	Encoder limit frequency	4-86
4.5	Enabling the safety–related functions	4-87
4.6	Switching the system on/off	4-88
5	Safety–Related Functions	5-91
5.1	Basic mechanisms of SI functions	5-91
5.1.1	Safe standstill – disconnecting the energy feed	5-91
5.1.2	Shutdown paths	5-92
5.1.3	Testing the shutdown paths	5-96
5.1.4	Overview of the machine data for the shutdown paths	5-102
5.1.5	Stop responses	5-103
5.1.6	Overview of the machine data for a stop response	5-114
5.2	External STOPs	5-116
5.2.1	Test stop for external STOPs	5-120
5.2.2	Overview of the machine data for the "external STOPs" function	5-124
5.3	Safe standstill (SH)	5-126
5.3.1	Overview of the machine data for the SH function	5-128
5.4	Safe operating stop (SBH)	5-129
5.4.1	Selecting/de–selecting the safe operating stop	5-130
5.4.2	Effects when the limit is exceeded for SBH	5-133
5.4.3	Overview of the machine data for the SBH function	5-135
5.5	Safely–reduced speed	5-136
5.5.1	Selecting/de–selecting safely reduced speed	5-138
5.5.2	Effects when the limit value is exceeded for SG	5-141

5.5.3	SG specific stop responses	5-143
5.5.4	Override for safely-reduced speed	5-143
5.5.5	Example: Override for safely-reduced speed	5-147
5.5.6	Application example for SG	5-149
5.5.7	Overview of the machine data for the SG function	5-149
5.6	Safe software limit switches (SE)	5-151
5.6.1	Effects when an SE responds	5-152
5.6.2	Overview of the machine data for the SE function	5-154
5.7	Safe software cams (SN)	5-155
5.7.1	Effects when SN responds	5-160
5.7.2	Application example for "safe software cams"	5-161
5.7.3	Overview of machine data for the SN function	5-165
5.8	Safe braking ramp (SBR)	5-167
5.8.1	Overview of machine data for SBR	5-169
5.9	Safety-related input/output signals (SGE/SGA)	5-171
5.9.1	Signal processing for the NCK monitoring channel	5-179
5.9.2	Signal processing in the drive monitoring channel	5-182
5.9.3	Overview of machine data for SGE/SGA	5-184
5.10	Safe programmable logic (SPL)	5-185
5.10.1	NCK-SPL program	5-191
5.10.2	Starting the NCK-SPL using the PROG_EVENT mechanism (from SW 6.4.15)	5-193
5.10.3	Starting the NCK-SPL from the PLC user program	5-196
5.10.4	Linking the NCK-SPL to the I/O and monitoring channel	5-198
5.10.5	Diagnostics/commissioning	5-200
5.10.6	Safety software relay (from SW 6.3.30)	5-202
5.10.7	System variables for SINUMERIK 840D	5-209
5.10.8	Behavior after power on/mode change/reset	5-212
5.10.9	SPL data on the PLC side	5-212
5.10.10	Direct communications between the NCK and PLC-SPL (from SW 6.3.30)	5-215
5.10.11	PLC data block (DB 18)	5-218
5.10.12	Forced checking procedure of SPL signals	5-224
5.11	SI I/Os using fail-safe modules connected to PROFIBUS-DP (from SW 6.3.30)	5-228
5.11.1	Description of functions	5-228
5.11.2	System prerequisites	5-229
5.11.3	System structure	5-231
5.11.4	Configuring and parameterizing the ET 200S F I/O	5-232
5.11.5	Parameterizing the F master (NCK)	5-238
5.11.6	Parameterizing the PROFIsafe communication (NCK)	5-238
5.11.7	Parameterizing the SPL-SGE/SGA interface (up to SW 7.1)	5-241
5.11.8	Parameterizing the SPL-SGE interface (NCK) (from SW 7.2)	5-242
5.11.9	Parameterizing the SPL-SGA interface (NCK) (from SW 7.2)	5-246
5.11.10	Module type (NCK)	5-249
5.11.11	Axial checksum (NCK)	5-249
5.11.12	Parameterizing the F master (PLC)	5-250
5.11.13	Response times	5-250
5.11.14	Functional limitations	5-253

6	Data Description	6-255
6.1	Machine data for SINUMERIK 840D	6-255
6.1.1	Overview of the machine data	6-255
6.1.2	Description of machine data	6-259
6.2	Machine data for SIMODRIVE 611digital	6-304
6.2.1	Overview of the machine data	6-304
6.2.2	Description of machine data	6-307
6.3	System variables	6-325
6.3.1	System variables for SINUMERIK 840D	6-325
6.3.2	Description of the system variables	6-328
6.4	Interface signals	6-338
6.4.1	Interface signals for SINUMERIK 840D	6-339
6.4.2	Description of the interface signals	6-339
7	Start-up (Commissioning)	7-349
7.1	Commissioning SINUMERIK 840D	7-350
7.1.1	Commissioning conditions	7-350
7.1.2	First commissioning	7-352
7.1.3	Series commissioning	7-356
7.1.4	Upgrading software	7-356
7.1.5	Changing data	7-357
7.2	Acceptance report	7-359
7.3	Conventional acceptance test	7-364
7.4	NCK acceptance test support	7-366
7.4.1	Scope of the test list	7-367
7.4.2	Internal mechanisms to support the test procedure	7-368
7.4.3	Trace techniques	7-372
7.4.4	Basic operating information and instructions	7-373
8	Diagnostics	8-375
8.1	Troubleshooting procedure	8-375
8.1.1	Service displays	8-376
8.1.2	Diagnostics support by configuring your own extended alarm text	8-380
8.1.3	Servo trace bit graphics for Safety Integrated	8-383
8.1.4	Bit graphics for SI signals in the servo trace	8-386
8.2	Alarms for Sinumerik 840D	8-391
8.3	Alarms from SIMODRIVE 611digital	8-447
8.4	PLC alarms	8-463
8.5	Reducing the number of alarms	8-464
8.5.1	Suppressing alarms	8-464
8.5.2	Assigning priorities to alarms	8-465
9	Interaction with Other Functions	9-469
9.1	SG-specific limiting of the setpoint velocity	9-469
9.2	Setpoint changeover (from SW 7.2)	9-471
9.3	Measuring system changeover	9-474

9.4	Gantry axes	9-474
9.5	Vertical axis	9-475
9.6	Parking axis	9-475
9.7	OEM applications	9-476
9.8	Overtemperature	9-477
9.9	Behavior of Safety Integrated when the drive bus fails	9-479
9.9.1	Behavior of the axial NCK monitoring channel	9-480
9.9.2	Behavior without NCK–SPL	9-480
9.9.3	Behavior with NCK–SPL	9-480
9.9.4	Behavior of the drive monitoring channel	9-482
9.9.5	SGE/SGA processing in the PLC	9-482
9.9.6	Limitations/constraints	9-483
9.9.7	Examples	9-483
10	Engineering and Application Examples	10-487
10.1	General information on engineering	10-487
10.2	Circuit examples	10-489
10.2.1	Control and drive components	10-490
10.2.2	Engineering	10-491
10.3	Safety Integrated with SPL	10-494
10.3.1	Starting configuration in the OB100	10-496
10.3.2	Starting the NCK–SPL and PLC–SPL	10-498
10.3.3	Declaring variables	10-502
10.3.4	Connecting–up the drives	10-512
10.3.5	Emergency Stop	10-516
10.3.6	Test stop	10-522
10.3.7	Protective door interlocking	10-535
10.3.8	De–selecting SBH using the key–operated switch	10-537
10.3.9	SG changeover	10-538
10.3.10	NCK–SPL	10-540
10.3.11	PLC blocks	10-543
10.3.12	Appendix	10-552
10.4	Safety Integrated without SPL	10-556
10.4.1	Connecting–up the drives	10-556
10.4.2	Emergency Stop and connecting–up the I/R module	10-557
10.4.3	Test stop	10-559
10.4.4	Protective door interlocking	10-560
10.4.5	De–selecting SBH using the key–operated switch/SG changeover using the door safety contactor	10-561
10.5	External STOPs	10-563
10.6	Application example with PROFIsafe connection	10-567
10.6.1	Software prerequisites	10-567
10.6.2	Functional scope of the application	10-567
10.6.3	Connecting–up the sensors and actuators	10-568
10.6.4	Parts list for the configured ET 200S line–up	10-568
10.6.5	Signal assignment and significance	10-569
10.6.6	Individual functions of the application	10-576
10.6.7	Configuring and connecting–up the ET 200S I/O	10-577

10.6.8	Parameterization Sinumerik 840D NCK	10-585
10.6.9	Programming the NCK-SPL	10-587
10.6.10	Programming the PLC-SPL	10-590
10.6.11	Modified limitations with PROFIsafe	10-595
10.7	Conventional brake control (single-channel from the PLC)	10-595
10.8	Two-channel brake control with SI (SPL)	10-597
10.9	Safe brake test (SBT)	10-602
10.9.1	Applications	10-602
10.9.2	Parameterization	10-602
10.9.3	Sequence	10-606
10.9.4	Limitations/secondary conditions	10-610
10.9.5	Activating	10-611
10.9.6	Examples	10-611
10.10	Safe cams at the modulo limit	10-613
10.11	SPL functionality without real drives	10-620
10.12	Direction detection when retracting from SE	10-622
10.13	Replacing a motor or encoder	10-625
10.14	Service functionality for axes with two encoder systems	10-632
10.15	Examples for safely entering gearbox ratios	10-632
10.16	Example for spindles with 2 encoders and drive with slip	10-640
10.17	Example for combining SI with ESR	10-643
A	Appendix	A-649
A.1	Customer Support	A-649
A.2	Fault analysis tables	A-651
A.3	References	A-656
A.4	Abbreviations	A-658
A.5	Terms	A-662
	Index	I-665

Regulations and Standards

1.1 General information

1.1.1 Objectives

Manufacturers and operating companies of equipment, machines and products are responsible for ensuring the appropriate level of safety. This results in the requirement that plants, machines and other equipment should be made as safe as possible according to state-of-the-art technology. In this case, companies describe in the various Standards, state-of-the-art technology that is relevant for safety. When the relevant Standards are complied with, it can be ensured that state-of-the-art technology has been utilized and therefore the erector/builder of a plant or a manufacturer of a machine or a piece of equipment has fulfilled his appropriate responsibility.

Safety systems are intended to play their role in keeping potential hazards for both people and the environment as low as possible by using suitable technical equipment, without restricting, more than absolutely necessary, industrial production and the use of machines. The protection of man and environment has to be put on an equal footing in all countries by applying rules and regulations that have been internationally harmonized. At the same time, this is also intended to avoid that safety requirements in different countries have an impact on the competitive situation – i.e. the intention is to facilitate international trade.

There are different concepts and requirements in the various regions and countries of the world when it comes to ensuring the appropriate degree of safety. The legislation and the requirements of how and when proof is to be given and whether there is an adequate level of safety are just as different as the assignment of responsibilities.

What is important for manufacturers of machines and companies that erect plants and systems is that always the local legislation and regulations apply where the machine or plant is being operated. For instance, the control system of a machine, that is to be used in the US, must fulfill the local US requirements even if the machinery construction company (OEM) is based in Europe.

1.1 General information

1.1.2 Functional safety

Safety, from the perspective of the object to be protected, cannot be split-up. The causes of hazards and therefore also the technical measures to avoid them can vary significantly. This is the reason that a differentiation is made between different types of safety – e.g. by specifying the cause of possible hazards. "Functional safety" is involved if safety depends on the correct function.

In order to achieve the functional safety of a machine or plant, it is necessary that the safety-related parts of the protection and control devices function correctly. And not only this, when faults develop, they must behave so that either the plant remains in a safe state or it is brought into a safe state.

In this case, it is necessary to use specially qualified technology that fulfills the requirements described in the associated Standards. The requirements to achieve functional safety are based on the following basic goals:

- Avoiding systematic faults
- Controlling systematic faults
- Controlling random faults or failures

The measure for the achieved functional safety is the probability of dangerous failures, the fault tolerance and the quality that should be guaranteed as a result of freedom from systematic faults. This is expressed in the Standards using different terms. In IEC 61508: "Safety Integrity Level" (SIL), in EN 954: "Categories" and ISO 13849-1 "Performance Level" (PL) (this has still not been ratified).

1.2 Safety of machinery in Europe

The EU Directives, that apply to the implementation of products, based on Article 95 of the EU contract, that regulates the free exchange of goods. These are based on a new global concept ("new approach", "global approach"):

- EU Directives only specify generally valid safety goals and define basic safety requirements.
- Technical details can be defined in Standards by Standards Associations that have an appropriate mandate from the EU Commission (CEN, CENELEC). These Standards are harmonized under a specific Directive and are listed in the Official Journal of the EU. When the harmonized Standards are complied with, then it can be assumed that the safety requirements and specifications of the Directives involved are fulfilled.
- Legislation does not specify that certain standards have to be complied with. However, when specific Standards are complied with, then it can be assumed that the safety goals of the EU Directives involved are also fulfilled.
- EU Directives specify that the Member States must mutually recognize domestic regulations.

The EU Directives are equal. This means that if several Directives apply for a specific piece of equipment or device, then the requirements of all of the relevant Directives apply (e.g. for a machine with electrical equipment, then the Machinery Directive and the Low-Voltage Directive apply).

1.2.1 Machinery Directive (98/37/EC)

With the introduction of a European common market, a decision was made that the domestic Standards and regulations of all of the EU Member States – that are involved with the technical implementation of machines – would be harmonized. This means that the Machinery Directive had to be implemented – as an internal market Directive – as far as the content was concerned – in the domestic legislation of the individual Member States. For the Machinery Directive, this was realized with the objective to achieve standard protective goals thus removing trade barriers resulting from technical differences. Corresponding to its definition "a machine is an assembly of linked parts or components – at least one of which moves", this Directive is extremely extensive. The range of applications was subsequently expanded to include "safety-related components" and "exchangeable equipment" in the form of revision Directives.

The Machinery Directive involves the implementation of machines. It has 14 Articles and 7 Annexes. The basic safety and health requirements specified in Annex I of the Directive must be fulfilled for the safety of machines. The manufacturer must carefully observe the following principles when it comes to integrating safety (Annex I, Paragraph 1.1.2):

- a) "Machinery must be constructed that it is fitted for its functions, and can be adjusted and maintained without putting persons at risk when these operations are carried-out under the conditions foreseen by the manufacturer."

1.2 Safety of machinery in Europe

"The measures must...eliminate...any risks of accidents...!"

- b) "When selecting the appropriate solutions, the manufacturer must apply the following basic principles – and more precisely, in the specified sequence:
- Eliminate or minimize hazards (by integrating the safety concept into the development and construction of the machine);
 - Apply and use the necessary protective measures to protect against dangers that cannot be avoided;
 - Inform the user about the residual dangers due to the fact that the safety measures applied are not completely effective."

The protective goals must be responsibly implemented in order to fulfill the requirements for conformity with the Directive.

The manufacturer of a machine must provide proof that his machine is in compliance with the basic requirements. This proof is made more simple by applying harmonized Standards.

1.2.2 Harmonized European Standards

The two Standards Organizations CEN (Comité Européen de Normalisation) and CENELEC (Comité Européen de Normalisation Électrotechnique), mandated by the EU Commission, drew-up harmonized European Standards in order to precisely specify the requirements of the EU Directives for a specific product. These Standards (EN Standards) are published in the Official Journal of the European Communities and must be included in domestic standards without any revisions. These are used to fulfill the basic health and safety requirements and the protective goals specified in Annex I of the Machinery Directive.

When the harmonized Standards are complied with, then there is an "automatic assumption" that the Directive is fulfilled. This means that the manufacturer may then assume that he has complied with the safety aspects of the Directive under the assumption that they are also handled in that particular Standard. However, not every European Standard is harmonized in this sense. The listing in the Official European Journal is decisive.

The European Standards for Safety of Machines is hierarchically structured as follows:

- A Standards (Basic Standards)
- B Standards (Group Standards)
- C Standards (Product Standards)

Regarding Type A Standards/Basic Standards

A Standards include basic terminology and definitions that are applicable for all machines. This includes EN ISO 12100 (previously EN 292) "Safety of Machines, Basic Terminology, General Design Principles."

A Standards primarily address those bodies setting the B and C Standards. However, the techniques documented there regarding minimizing risks can also be helpful to manufacturers if there are no applicable C Standards.

Regarding Type B Standards/Group Standards

B Standards include all Standards with safety-related statements that can involve several machine types.

B Standards also primarily address those bodies setting C Standards. However, they can also be helpful for manufacturers when designing and constructing a machine if no C Standards apply.

For B Standards, an additional sub-division is made – and more precisely as follows:

- **Type B1 Standards** for higher-level safety aspects, e.g. basic ergonomic principles, safety clearances from hazards, minimum clearances to avoid crushing parts of the body.
- **Type B2 Standards** for protective safety devices are defined for various machine types – e.g. Emergency Stop devices, two-hand operating circuits, interlocking elements, contactless protective devices, safety-related parts of controls.

Regarding Type C Standards/Product Standards

C Standards are Standards for specific machines – for instance, machine tools, woodworking machines, elevators, packaging machines, printing machines etc. Product Standards list requirements for specific machines. The requirements can, under certain circumstances, deviate from the Basic and Group Standards. For machinery construction companies (e.g. OEMs), Type C Standards/Product Standards have absolutely the highest priority. The machinery construction company can then assume that it fulfills the basic requirements of Attachment I of the Machinery Directive (automatic presumption of compliance).

If, for a particular machine, no Product Standard is available, then Type B Standards can be used as help when designing and constructing a machine.

All of the listed Standards as well as the mandated Draft Standards are provided in the Internet under:

<http://www.newapproach.org/>

Recommendation: Technical development is progressing at a tremendous pace and with it changes and modifications to machine concepts. This is the reason that especially when using C Standards, it should be carefully checked as to whether they are still up-to-date. Where relevant, it should be noted that it is not mandatory that the Standard is applied but that the safety goal must be achieved.

1.2 Safety of machinery in Europe

1.2.3 Standards to implement safety-related programmable electronic controls

If the functional safety of the machine depends on control functions, then the control must be implemented so that the probability of failure of the safety-related functions is sufficiently low. This is the reason that Standard IEC 61508 must be carefully observed when using programmable electronic systems. ISO 13849-1 and EN 954-1 and IEC 62061 provide instructions specifically addressing the safety of machine controls.

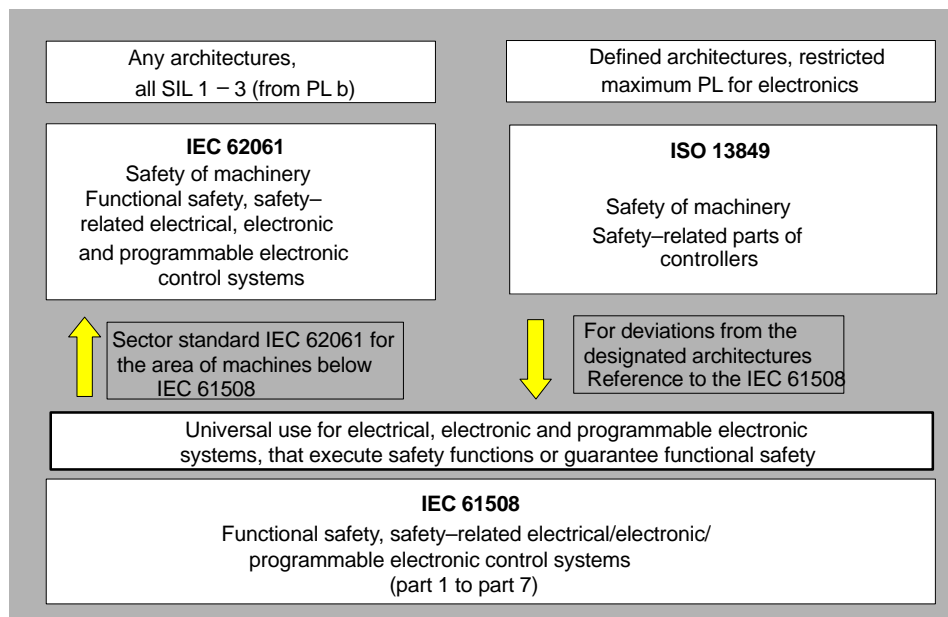

The areas of application of ISO 13849-1 and IEC 62061 are very similar. In order to help users make a decision, the IEC and ISO associations have defined in detail the application areas of both Standards in a common table in the introduction to the Standards. Either EN ISO 13849-1 or EN IEC 62061 is applied depending on the particular technology (mechanical, hydraulic, pneumatic, electrical, electronic, programmable electronic), risk classification and architecture.

	Systems to execute safety-related control functions	EN ISO 13849-1 (rev)	EN IEC 62061
A	Non-electrical (e.g. hydraulic, pneumatic)	X	No covered
B	Electromechanical (e.g. relay and/or basic electronics)	Limited to the designated architectures provided (refer to comment 1) and maximum, up to PL = e	All architectures and maximum, up to SIL 3
C	Complex electronics (e.g. programmable electronics)	Restricted to the designated architectures (refer to comment 1) and maximum, up to PL = d	All architectures and maximum, up to SIL 3
D	A combined with B	Restricted to the designated architectures (refer to comment 1) and maximum, up to PL = e	X Refer to comment 3
E	C combined with B	Restricted to the designated architectures (refer to comment 1) and maximum, up to PL = d	All architectures and maximum, up to SIL 3
F	C combined with A or C combined with A and B	X Refer to comment 2	X Refer to comment 3

"X indicates that the point is covered by this Standard.

Comment 1:
Designated architectures are described in Annex B of EN ISO 13849-1 and provide a simplified basis for the quantification

Comment 2:
For complex electronics: Using designated architectures in compliance with prEN ISO 13849-1 (rev) up to PL = d or every architecture in compliance with EN IEC 62061

Comment 3:
For non-electrical systems: Use parts/components, that correspond to EN ISO 13849-1 (rev) as subsystems

1.2.4 pr EN/ISO 13849-1 (revision from EN 954-1)

The qualitative approach acc. to EN 954-1 is not sufficient for state-of-the-art controls as a result of their technology. EN 954-1 does not take into account, among other things, time behavior (e.g. test interval and/or cyclic test, lifetime). This results in the probabilistic basis in EN ISO 13849-1 (probability of failure per unit time).

EN ISO 13849-1 is based on the known categories of EN 954-1. It now takes into consideration complete safety functions with all of the devices involved in their execution. With EN ISO 13849-1, safety functions are investigated from a quantitative perspective going beyond the qualitative basis of EN 954-1. Performance levels (PL) are used, for this purpose, based on the various Categories. The following safety-related characteristic quantities are required for devices/equipment:

- Category (structural requirement)
- PL: Performance Level

1.2 Safety of machinery in Europe

- MTTF_d: meantime to dangerous failure
- DC: diagnostic coverage
- CCF: common cause failure

The Standard describes the calculation of the Performance Level (PL) for safety-related parts of controls on the basis of designated architectures. For deviations from this, EN ISO 13849-1 refers to IEC 61508.

When combining several safety-related parts to form a complete system, the Standard explains how to determine the resulting PL.

Note

EN ISO 13849-1 (rev) is available as Draft. Until it is ratified, which is scheduled for the end of 2005, EN 954-1 still applies for a transition period that is scheduled for three years: 1996.

1.2.5 EN IEC 62061

EN IEC 62061 is a sector-specific standard below IEC 61508. It describes the implementation of safety-related electrical control systems of machines and takes into account the complete lifecycle – from the conceptual phase to de-commissioning. Safety functions are considered from both quantitative and qualitative standpoints as basis.

In so doing, the Standard consequentially applies a top-down technique in implementing complex control systems – known as functional decomposition. Starting from the safety functions resulting from the risk analysis, a sub-division is made into sub-safety functions and these sub-safety functions are then assigned to real devices/equipment, subsystems and subsystem elements. Both the hardware as well as the software is taken into consideration. EN IEC 62061 also describes the requirements placed on implementing application programs.

A safety-related control system comprises various subsystems. The subsystems are described from a safety-related perspective using the characteristic quantities (SIL claim limit and PFH_D).

Safety-related characteristic quantities for subsystems:

- SILCL: SIL claim limit
- PFH_D: probability of dangerous failures per hour

- T1: lifetime

These subsystems can, in turn, consist of different interconnected subsystem elements (devices) with the characteristic quantities to determine the appropriate PFH_D value of the subsystems.

Safety-related characteristic quantities for subsystem elements (devices):

- λ : failure rate
- B10 value: For elements that are subject to wear
- T1: lifetime

For electro-mechanical devices, a manufacturer specifies a failure rate λ referred to the number of operating cycles. The failure rate per unit time and the lifetime must be determined using the switching frequency for the particular application.

Parameters to be defined for the subsystem – comprising subsystem elements – when designing equipment:

- T2: diagnostic test interval
- β : susceptibility to common cause failure
- DC: diagnostic coverage

The PFH_D value of the safety-related control is determined by adding the individual PFH_D values for subsystems.

The user has the following possibilities when configuring a safety-related control:

- To use devices and subsystems that already comply with EN 954-1 (or prEN ISO13849-1 (rev)) or IEC 61508 or EN IEC 62061. Information is provided in the Standard as to how qualified devices can be integrated when implementing safety-related functions.
- Develop of their own subsystems.
 - Programmable, electronic systems and complex systems: Apply IEC 61508, as well as EN 954-1 or ISO13849-1.
 - Simple devices and subsystems: Apply EN IEC 62061.

Data on non-electrical systems is not included in EN IEC 62061. The Standard represents an extensive system to implement safety-related electrical, electronic and programmable electronic control systems. EN 954-1/EN ISO 13849-1 should be applied for non-electrical systems.

Note

EN IEC 62061 is ratified as EN. It will be harmonized under the Machinery Directive in 2005.

1.2.6 DIN EN 61508 (VDE 0803) or IEC 61508

Standards of the IEC 61508 series were included as EN 61508 in the European Community and as DIN EN 61508 (VDE 0803) in Germany. These series of Standards describe state-of-the-art technology; however, they only have to be observed on a voluntary basis and they are not binding.

IEC 61508 is not harmonized under a particular European Directive. This means that it cannot be used as a basis for automatic presumption that the protective goals of a Directive are fulfilled. However, the manufacturer of a safety-related product can use IEC 61508 to fulfill basic requirements from the European Directives according to the new concept. For instance in the following cases:

- If there is no harmonized Standard for the application involved. In this particular case, the manufacturer may use IEC 61508. However, it has no presumption of conformity.
- A harmonized European Standard (e.g. EN 954 or ISO 13849, EN 60204-1) makes reference to IEC/EN 61508. This ensures that the appropriate requirements of the Directives are complied with ("standard that is also applicable"). If the manufacturer correctly applies IEC/EN 61508 in the sense of this reference and acts responsibly, then he uses the presumption of conformity of the referencing standard.

IEC 61508 handles, from a universal basis, all aspects that must be taken into consideration if E/E/PES systems (electrical, electronic and programmable electronic systems) are used in order to execute safety-related functions and to guarantee the appropriate level of functional safety. Other hazards – e.g. hazards as a result of electric shock are, similar to EN 954-1, not included in the Standard.

A new aspect of IEC 61508 is its international positioning as "International Basic Safety Publication", which makes it a framework for other sector-specific Standards (e.g. IEC 62061). As a result of its international positioning, this Standard enjoys a high acceptance worldwide – especially in North America and in the Automobile industry. Today, many regulatory bodies already specify it, e.g. as basis for NRTL listing.

A new aspect of IEC 61508 is also its system approach. This extends the technical requirements to the complete safety installation – from the sensor to the actuator – the quantification of the probability of dangerous failure due to random hardware failures and the generation of documentation associated with every phase of the complete safety-related lifecycle of the E/E/PES.

1.2.7 Risk analysis/assessment

As a result of their very design and functionality, machines and plants represent potential risks. This is the reason that the Machinery Directive specifies that a risk assessment is carried-out for every machine and, where necessary, risks are then reduced until the residual risk is less than the tolerable risk. For the techniques to evaluate these risks, the following Standards should be applied:

- EN ISO 12100 "Safety of Machinery – basic terminology, general principles for design" and
- EN 1050 "Safety of Machinery, general principles for assessing risk".

EN ISO 12100 mainly describes the risks to be considered and the design principles to minimize risks; EN 1050 describes the iterative process when assessing and reducing risks to achieve the appropriate degree of safety.

The risk assessment is a sequence of steps that allows hazards, as a result of machines, to be systematically investigated. Where necessary, a risk reduction procedure follows risk assessment. When this procedure is repeated, an iterative process is obtained (refer to Fig. 1-1), which can then be used to eliminate hazards as far as possible and so that the appropriate protective measures can be taken.

The risk assessment involves the following

- Risk analysis
 - a) Determines the limits of the particular machine (EN ISO 12100, EN 1050 Para. 5)
 - b) Identifies the hazards (EN ISO 12100, EN 1050 Para. 6)
 - c) Techniques to estimate risk (EN 1050 Para. 7)
- Risk evaluation (EN 1050 Para. 8)

As part of the iterative process to achieve the appropriate degree of safety, after the risk has been estimated, the risk is evaluated. In so doing, a decision must be made as to whether the residual risk must be reduced. If the risk is to be further reduced, suitable protective measures must be selected and also applied. The risk assessment should then be repeated.

1.2 Safety of machinery in Europe

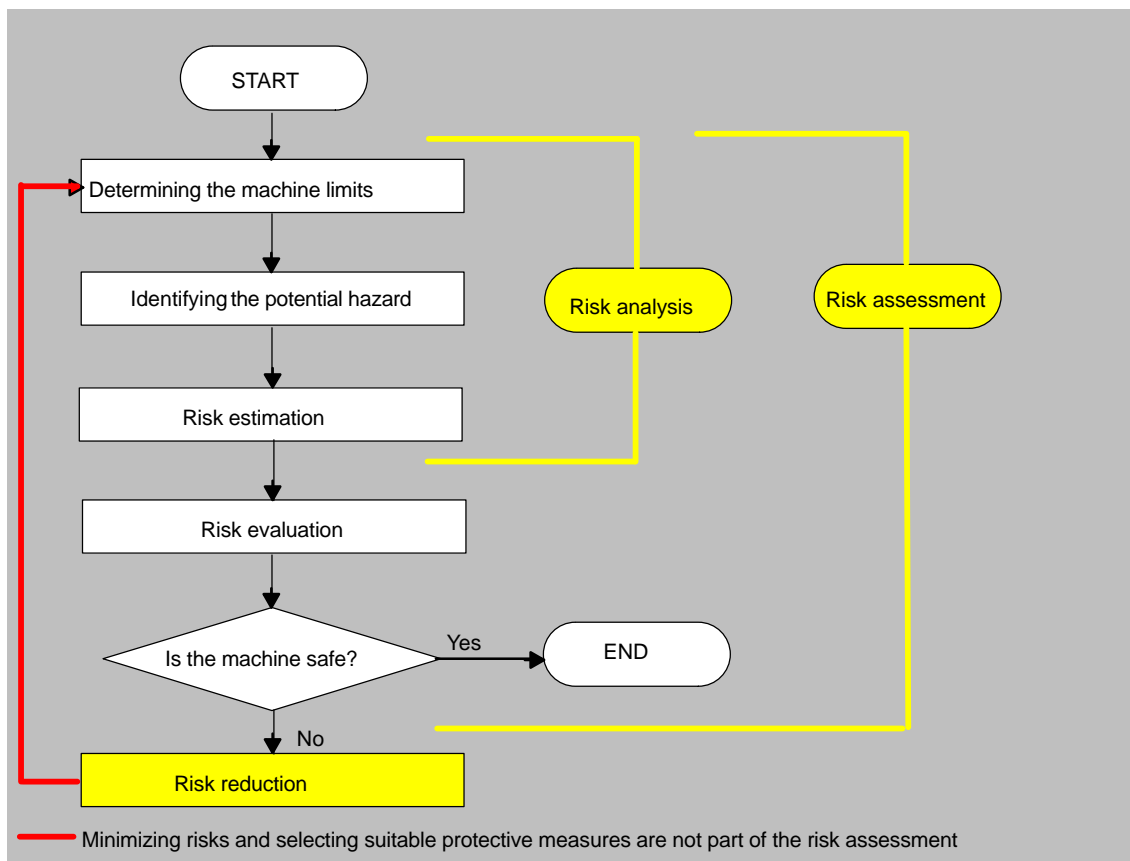

Fig. 1-1 Iterative process to achieve safety in compliance with ISO 14121 (EN 1050)

Risks must be reduced by suitably designing and implementing the machine. For instance a control system or protective measures suitable for the safety-related functions.

If the protective measures involve interlocking or control functions, then these must be designed and implemented acc. to EN 954/ISO 13849. For electrical and electronic controls, EN 62061 can be used as an alternative to EN 954/ISO 13849. Electronic controls and bus systems must also comply with IEC/EN 61508.

1.2.8 Risk reduction

Risk reduction for a machine can also be implemented using structural measurements and also safety-related control functions. To implement these control functions, special requirements must be taken into consideration – graduated according to the magnitude of the risk. These are described in EN 954–1 or ISO 13849–1 and, for electrical controls, especially programmable electronics in IEC 61508 or IEC 62061.

The requirements placed on safety-related parts of controls are graduated and classified according to the magnitude of the risk and the necessity to reduce risk.

EN 954–1 defines "Categories" for this purpose. In its Annex B, it also describes a technique to select a suitable Category to design and implement the safety-related part of a control system. In the future, a new risk diagram will be provided in the New Edition (EN ISO 13849–1). Instead of categories, this risk diagram will lead to hierarchic Performance Levels (PL).

IEC 62061 uses "Safety Integrity Level" (SIL) to make this type of classification. This is a quantified measure for the safety-related performance of a control. The necessary SIL is also determined using the principle of risk assessment according to ISO 14121 (EN 1050). A technique to determine the required Safety Integrity Level (SIL) is described in Annex A of the Standard.

It is always important, independent of which Standard is applied, that all parts of the machine control that are involved in executing safety-related functions fulfill these requirements.

1.2.9 Residual risk

In our technological world, safety is a relative term. Unfortunately safety cannot be implemented to guarantee a "zero risk" situation. The remaining residual risk is defined as:

- Risk that remains after executing the protective measures.

In this case, protective measures are measures to minimize risks, that are known and correspond to state-of-the-art technology.

Residual risks must be clearly referred to in the machine/plant documentation (user information according to EN ISO 12100–2).

1.3 Machine safety in the US

An essential difference in the legal requirements regarding safety at work between the US and Europe is the fact that in the US there is no legislation regarding machinery safety that is applicable in all of the states and that defines the responsibility of the manufacturers/supplier. On the other hand, there is a general requirement that the employer must offer a safe workplace.

1.3.1 Minimum requirements of the OSHA

The Occupational Safety and Health Act (OSHA) from 1970 regulates the requirement that employers must offer a safe place of work. The core requirements of OSHA are in Section 5 "Duties".

The requirements of the OSH Act are administered by the Occupational Safety and Health Administration (also known as OSHA). OSHA employs regional inspectors that check whether workplaces are in compliance with the valid regulations.

The regulations of OSHA, relevant for safety at work, are described in OSHA 29 CFR 1910.xxx ("OSHA Regulations (29 CFR) PART 1910 Occupational Safety and Health"). (CFR: Code of Federal Regulations).

<http://www.osha.gov>

The application and use of the Standards is regulated in 29 CFR 1910.5 "Applicability of standards". The concept is similar to that used in Europe. Standards for specific products have priority over general Standards if the relevant aspects are handled there. When the Standard is fulfilled, the employer can assume that he has fulfilled the core requirements of the OSM Act regarding the aspects handled by the Standards.

In conjunction with certain applications, OSHA specifies that all electrical equipment and devices that are used to protect workers must be authorized by an OSHA-certified, Nationally Recognized Testing Laboratory (NRTL) for the specific application.

In addition to the OSHA regulations, it is important that the current standards from organizations such as NFPA and ANSI are carefully observed as well as the extensive product liability legislation that exists in the US. As a result of the product liability legislation, it is in their own interests that manufacturing and operating companies carefully maintain the applicable regulations and they are more or less "forced" to fulfill the requirement to use state-of-the-art technology.

Third-party insurance companies generally demand that their customers fulfill the applicable standards of the Standards Organizations. Initially, self-insured companies do not have this requirement, but, in the case of an accident, they must prove that they have applied generally recognized safety principles.

1.3.2 NRTL Listing

All electrical equipment and devices that are used in the US to protect workers must be certified for the particular application by a "Nationally Recognized Testing Laboratory" (NRTL) certified by OSHA. These "Nationally Recognized Testing Laboratories" are authorized to certify equipment and material in the form of listing, labeling or similar. Domestic standards such as the NFPA 79–2002 and also international Standards such as e.g. IEC 61508 for E/E/PES systems form the basis for testing.

1.3.3 NFPA 79

NFPA 79 (Electrical Standard for Industrial Machinery) applies to electrical equipment on industrial machines with rated voltages of less than 600 V. (A group of machines that operate together in a coordinated fashion is also considered to be one machine.)

The new of NFPA 79 – 2002 Edition includes some basic requirements for programmable electronics and communication buses if these are to be used to implement and execute safety–related functions. If these requirements are fulfilled, then electronic controls and buses can also be used for Emergency Stop functions, Stop Categories 0 and 1 (refer to NFPA 79 – 2002 9.2.5.4.1.4). Contrary to EN 60204–1, NFPA 79 specifies that for Emergency Stop functions, the electrical energy must be disconnected using electro–mechanical elements.

The core requirements placed on programmable electronics and buses include:
System requirements (refer to NFPA 79 – 2002 9.4.3)

- Control systems that include software–based controllers must,
 - (1) If an individual fault occurs,
 - bring the system into a safe state to shut it down
 - prevent restarting until the fault has been removed
 - prevent unexpected starting
 - (2) Provide protection comparable to hard–wired controls
 - (3) Be implemented corresponding to a recognized Standard that defines the requirements for such systems.

In a note, IEC 61508 is specified as a suitable Standard.

Requirements placed on programmable equipment (refer to NFPA 79 – 2002 11.3.4)

- Software and firmware–based controllers, that are used in safety–related functions, must be listed for such an application (i.e. certified by an NRTL).
A note states that IEC 61508 list the requirements to design such a controller. **Underwriter Laboratories (UL)** has defined a special Category for "Programmable Safety Controllers" for implementing this requirement (code NRGF). This category handles control devices that contain software and are used in safety–related functions.
The precise description of the Category and the list of devices that fulfill this requirement are listed in the Internet:

1.3 Machine safety in the US

<http://www.ul.com> → certifications directory → UL Category code/Guide information → search for category "NRGF"

TUV Rheinland of North America, Inc. is also an NRTL for these applications.

1.3.4 ANSI B11

ANSI B11 Standards are joint Standards, that were developed by associations such as e.g. the Association for Manufacturing Technology (AMT and the Robotic Industries Association (RIA).

The hazards of a machine are evaluated using a risk analysis/assessment. Risk analysis is an important requirement acc. to NFPA79–2002, ANSI/RIA 15.06 1999, ANSI B11.TR–3 and SEMI S10 (semiconductors). Using the documented results of a risk analysis, suitable safety systems can be selected based on the safety class obtained as a result of the particular application.

1.4 Machine safety in Japan

The situation in Japan is different than that in Europe and the US. Comparable legislation regarding functional safety such as in Europe does not exist. Further, product liability does not play a role such as it is in the US.

There are no legal requirements to apply Standards but an administrative recommendation to apply JISs (Japanese Industrial Standards):

Japan bases its approach on the European concept and uses basic Standards as its National Standards (refer to Table 1-1).

Table 1-1 Japanese Standards

ISO/IEC number	JIS number	Comment
ISO12100-1	JIS B 9700-1	Earlier designation TR B 0008
ISO12100-2	JIS B 9700-2	Earlier designation TR B 0009
ISO14121 (EN1050)	JIS B 9702	
ISO13849-1 (Ed. 1)	JIS B 9705-1	
ISO13849-2 (Ed. 2)	JIS B 9705-1	
IEC60204-1	JIS B 9960-1	Without Annex F or Route Map of the European Foreword
IEC61508-1 to 7	JIS C 0508	
IEC 62061		A JIS number has still not been assigned

1.5 Equipment regulations

In addition to the requirements specified in Directives and Standards, company-specific requirements should also be carefully taken into account. Especially large corporations – e.g. automobile manufacturers – place high requirements on the automation components, that are then often listed in their own equipment specifications.

Safety-related subjects (e.g. operating modes, operator actions with access to hazardous areas, Emergency Stop Concepts...) should be clarified with customers at an early phase so that they can be integrated in the risk assessment/risk reduction.

1.6 Other safety-related subjects and issues

1.6.1 Information sheets from the various regulatory bodies

Safety-related measures to be implemented cannot always be derived from Directives, Standards and Regulations. In this case, supplementary information and explanations are required.

As part of their function, some regulatory bodies issue publications on an extremely wide range of subjects. Information sheets are, for example, available on the following subjects:

- Process monitoring in production environments
- Axes that can fall due to gravity
- Roller pressing machines
- Lathes and turning centers – purchasing/selling

These information sheets handling specific subjects and issues can be ordered from all parties interested – e.g. for providing support in operations, when drawing-up regulations or for implementing safety-related measures at machines, plants and systems. These information sheets provide support in machinery construction, production systems, steel construction.

The information sheets can be downloaded from the following Internet addresses:

<http://www.bgmetallsued.de/downloads>

There, the Category "Fachausschuss Infoblätter" should be selected.

1.6.2 Safety Integrated System Manual

In the Safety Integrated System Manual (5th Edition), additional information regarding Regulations and Standards is provided in the Chapters listed below:

- Chapter 1: Regulations and Standards
- Chapter 2: Specification and design of safety-related controls for machines

Short Description

2.1 Control/drive system

In order to implement safety-related measures, up until now, external equipment and devices were used – e.g. contactors, switches, cams and monitoring devices. If a hazardous situation is detected, these devices generally interrupt the power circuit thus stopping the motion, refer to Fig. 2-1.

By integrating safety functions, drive systems and CNC controls perform safety functions in addition to their functional tasks. Very short response times can be achieved because of the short data paths from acquisition of the safety-related information – e.g. speed or position – up to evaluation. The systems with integrated safety technology generally respond very quickly when the permissible limit values are violated, e.g. position and velocity limit values. They can be of decisive importance for the required monitoring result. The integrated safety technology can directly access the power semiconductors in the drive controller without using electromechanical switching devices in the power circuit. This helps reduce the susceptibility to faults – and the integration also reduces the amount of cabling.

2.1 Control/drive system

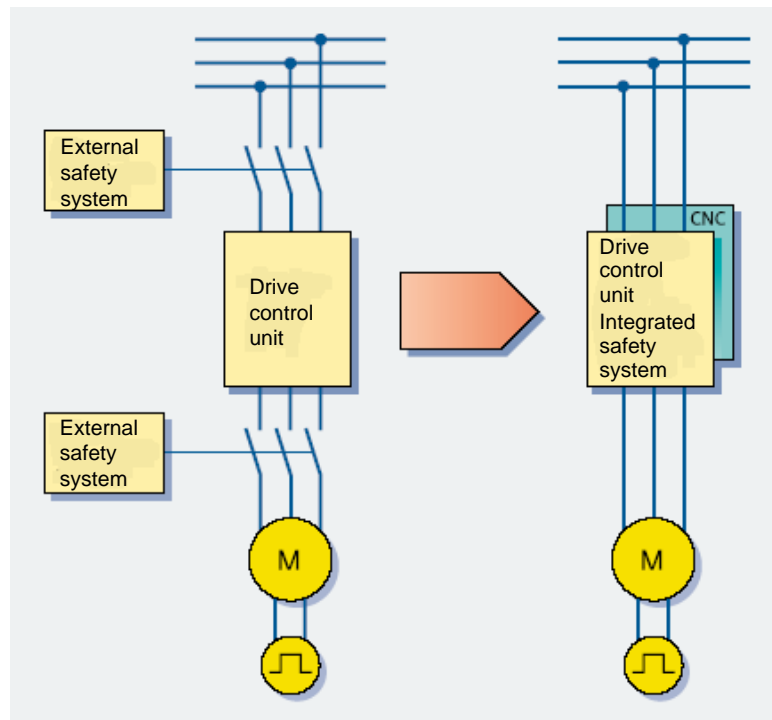

Fig. 2-1 Safety systems: External → Integrated

SINUMERIK Safety Integrated

Using the "SINUMERIK Safety Integrated" function, for SINUMERIK 840 D, for all power/performance classes, integrated safety functions are available in conjunction with the SIMODRIVE 611digital drive converter system; these are used to monitor standstill (zero speed), velocity and position.

SINUMERIK Safety Integrated is available for all power/performance classes of SINUMERIK 840D.

The digital control modules of SIMODRIVE 611digital are used in conjunction with the SIMODRIVE three-phase servomotors 1FT6/1FK6/1FK7 and linear motors 1FN for feed drives as well as 1FE and 1PH motors for main spindle drives.

The safety-related sensors and actuators are either connected through separate I/O of the NC and PLC or through distributed I/O via PROFIBUS-DP with the PROFIsafe profile – e.g. ET 200S, ET 200eco.

This means that a complete digital system is available that is suitable for complex machining tasks.

2.2 SI system structure and basic features

A two-channel, diverse system structure is formed on the basis of an existing multi-processor structure.

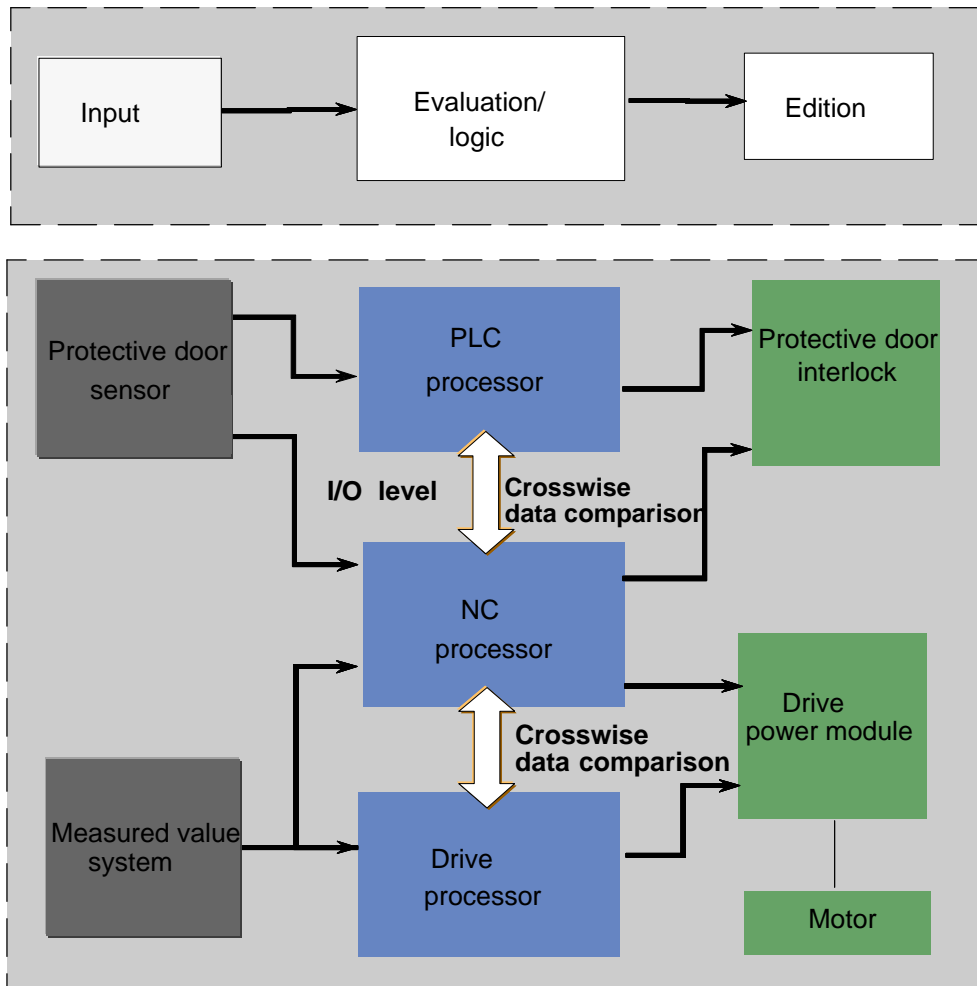

Fig. 2-2 Evaluation/logic with integrated monitoring functions

Features of the two-channel, diverse structure

A two-channel, diverse structure is characterized by the following features:

- Two-channel structure with at least 2 independent computers (i.e. computers with different hardware and software).
- Crosswise result and data comparison with forced checking procedure in order to be able to itself detect faults in functions that are infrequently used (dormant faults).
- The computers can access data, reaction-free and decoupled at the shared (common) interfaces (e.g. actual value input).

2.2 SI system structure and basic features

Sensing

The 611 digital control module senses the actual values of the individual axes through the first actual value input for a 1–encoder system and through the first and second actual value input for a 2–encoder system; it provides this data to the control and the drive in both cases, through 2 separate actual value channels.

In order to connect sensors and actuators in a safety–related fashion, their process signals must be connected–in for further processing.

The following connection versions are possible:

1. Through separate I/O of the PLC and NC
2. Through common I/O via PROFIBUS–DP with the PROFIsafe profile, e.g. SIMATIC ET 200S, ET 200eco
The fail–safe modules of the ET 200M cannot be generally used as the associated IM module is not a standard slave

Evaluating

The safety–related functions are executed independently of one another by the NCK–CPU, PLC–CPU and the drive CPU. The CPUs cyclically and mutually compare their safety–related data and results (crosswise data comparison). A test can be carried–out – initiated by the CPUs – to check the shutdown paths and actuators (forced checking procedure).

Responding

When the integrated safety–related functions respond, then the drive processor, the PLC processor and/or the NCK processor can influence the connected actuators in a safety–related fashion in–line with the actual situation.

2.3 Overview, SI functions

The safety-related functions are available in all of the operating modes and can communicate with the process via safety-related input/output signals. These can be implemented individually for each axis.

- **Safe stopping process**
When a monitoring function or a sensor responds (e.g. a light grid), the drives are safely controlled down to standstill, optimally adapted to the actual operating state of the machine.
- **Safe braking ramp (SBR)**
Monitors the speed characteristic. The speed must be reduced after a stop request has been issued.
- **Safe standstill (SH)**
The drive pulses are cancelled. The energy feed is safely and electronically disconnected.
- **Safe operating stop (SBH)**
Monitors the drives during standstill (to ensure that they remain stationary). The drives remain fully functional in closed-loop control.
- **Safely-reduced speed (SG)**
Configured speed limits are monitored, e.g. when setting-up without using an agreement button.
- **Safe software limit switches (SE)**
Variable traversing range limits
- **Safe software cams (SN)**
To detect ranges
- **Safety-related input/output signals (SGE/SGA)**
Interface to the process
- **Safety-related communication via standard bus**
Distributed I/Os for process and safety signals are connected via PROFIBUS using the PROFIsafe protocol.
- **Safe programmable logic (SPL)**
All of the safe signals and internal logic are directly connected.
- **Safe brake management (SBM)**
Two-channel brake control and cyclic brake test
- **Integrated acceptance test**
Partially automated acceptance test for all safety-related functions. Simple operation of the test process, automatic configuration of Trace functions and automatic generation of an acceptance report.

Space for your notes

System Features

3.1 Certification

The test certificates and PRÜF mark are listed in the Foreword.

3.1.1 Certification acc. to EN 954–1/VDE 801

The safety–related functions that are available under the name "SINUMERIK Safety Integrated" with the SINUMERIK 840D powerline system were certified for the first time in 1996. They fulfill the requirements of Category 3 according to EN 954–1 (with the exception of the safety–related brake test that corresponds to the requirements of Category 2). Standards EN 954–1 and DIN V VDE 0801 were the basis for the tests carried–out. At this time, DIN V VDE 0801 was the only Standard that was available on the subject "basics for computers in systems with safety–related function". In the meantime, DIN V VDE 0801 was officially withdrawn effective 1.8.2004.

If the SINUMERIK 840D powerline system is used in Europe, this certification is still applicable until the associated Certificate has expired on 26.07.2009 – even if the previous test basis DIN V VDE 0801 was in the meantime withdrawn. Machines, that were commissioned before the certificate expired, still fulfill the Machinery Directive.

The certificate acc. to EN 954–1/VDE 801 is valid for software releases up to and including SW 6.5.

3.1 Certification

3.1.2 Certification acc. to EN 954–1/IEC 61508

In order to further increase the level of acceptance of the system outside Europe and to maintain the certification in the future, the system has now also been certified according to the new IEC 61508. The safety functions fulfill the requirements of Category 3 according to EN 954 and SIL 2 (Safety Integrity Level) acc. to IEC 61508 (with the exception of the safety–related brake test that corresponds to the requirements of Category 2).

If the SINUMERIK 840D powerline system with the SINUMERIK Safety Integrated safety–related functions are to be operated, referencing this certificate, then certain additional limitations and restrictions must be complied with (refer to Chapter 3.6).

The certificate acc. to EN 954–1/IEC 61508 is valid from software release SW 6.4.15 (up to and including).

3.1.3 NRTL Listing/NFPA 79–2002

In order to secure the acceptance specifically in the US, the system was also listed by an NRTL (Nationally Recognized Testing Laboratory) corresponding to the requirements of NFPA 79–2002 (electrical standard for industrial machinery). The certification according to IEC 61058 is the basis for this.

If the system is to be operated, referencing this NRTL listing, then additional limitations/restrictions must be carefully complied with (refer to Chapter 3.6.8).

3.2 Fault analysis

3.2.1 Monitoring functions

The SINUMERIK 840D control with SIMODRIVE 611digital is equipped with various standard monitoring functions. These functions detect system faults/errors and initiate specific responses (also refer to the appropriate literature). These standard monitoring functions do not comply with EN 954–1 or IEC 61508.

The safety functions of SINUMERIK Safety Integrated with their crosswise data comparison and the forced checking procedure detects system faults and bring the machine into a safe condition (refer to Chapter 5, "Safety–Related Functions").

3.2.2 Fault analysis

Based on the appropriate Directives and Standards, a detailed fault analysis is carried–out using SINUMERIK Safety Integrated. The brief edition in tabular form, listed in Attachment A, shows the various disturbances and system faults controlled by SINUMERIK Safety Integrated) with an extremely low residual risk; whereby the basis was disturbances that are already known. Further, a quantified value for the probability of failure of the safety–related functions due to random hardware faults is available (refer to Chapter 3.3).

3.3 Probability of failure

Acc. to IEC 61508, the probability of failure of E/E/PES systems must be calculated according to random hardware faults.

This is the reason that SINUMERIK Safety Integrated is sub-divided into subsystems:

- Subsystem **"SINUMERIK 840D/SIMODRIVE 611digital"**, comprising SINUMERIK 840D-NCU and SIMODRIVE 611 digital control
- Subsystem **"Standard SIMATIC/SINUMERIK I/O"**, comprising SINUMERIK DMP modules and SIMATIC standard I/O modules ET 200M and ET 200S.

The subsequently specified probability of failure figures only apply under the prerequisites that the limitations/constraints for the forced checking procedure (refer to Chapter 4.3) and the limitations/constraints for permissible system components (refer to Chapter 3.6) are complied with

3.3.1 Subsystem **"SINUMERIK 840D/ SIMODRIVE 611digital"**

The subsystem **"SINUMERIK 840D/SIMODRIVE 611digital"** has, according to IEC 61508, the following features:

- SIL capability: SIL 2
- Mode: "high demand/continuous mode"
- PFH_D ("probability of a dangerous failure per hour")
The safety-related function of a machine can involve several axes. This is the reason that the PFH_D value is specified depending on the number of drive controls that are used.

The PFH_D value, comprises the following components:

- for SINUMERIK 840D NCU $1.2 \cdot 10^{-8}/h$;
- for SIMODRIVE 611digital, single-axis control, each $3.8 \cdot 10^{-8}/h$;
- for SIMODRIVE 611digital, double-axis control, each $4.5 \cdot 10^{-8}/h$;

With **"ne"** as number of "1-axis controls" and **"nd"** as the number of 2-axis controls", the PFH_D value of the subsystem **"SINUMERIK 840D/SIMODRIVE 611digital"** can be calculated as follows:

$$\text{PFH}_D = 1.2 \cdot 10^{-8}/h + ne \cdot 3.8 \cdot 10^{-8}/h + nd \cdot 4.5 \cdot 10^{-8}/h;$$

The following conditions must be complied with for this calculation: $nd+ne > 0$;
and $\text{PFH}_D < 10^{-6}/h$;

Example for 6 axes, realized with 2 single-axis controls and 2 double-axis controls:

$$\text{PFH}_D (ne=2, nd=2) = 1.2 \cdot 10^{-8}/h + 2 \cdot 3.8 \cdot 10^{-8}/h + 2 \cdot 4.5 \cdot 10^{-8}/h = 1.78 \cdot 10^{-7}/h$$

- Maximum total operating time ("mission time"): 10 years

This data is applicable for all safety-related functions (SH, SBH, SG etc.) of SINUMERIK Safety Integrated including their logical combinations using safe programmable logic (SPL).

All of the components mentioned above to implement the axis controls used belong to the PFH_D of a safety-related function defined on the user side. This also applies to 2-axis controls even though only one of the axes is involved in the safety-related function. The PFH_D contributions are only applicable under the prerequisite that there is no danger involved referred to the controlled process when the motor or motors are switched into a no-current condition (no-torque condition) when the fault occurs. Even if only the safe programmable logic is used, at least one-axis control or a 2-axis control must be installed and incorporated.

The "safe brake test" (SBT) is an exception to this rule. Within the scope of IEC 61508, this does not represent a safety-related function; this means that it is not possible to specify a PFH_D value. Within the scope of IEC 61508, the "safe brake test" (SBT) represents a suitable diagnostics function to claim a DC ("diagnostic coverage") of up to 99%* ("high") for the available mechanical holding braking torque of a mechanical holding brake that is controlled through 2 channels and is subject to a forced checking procedure on a regular basis.

***) Safety instruction**

Brakes must be dimensioned according to their use. In so doing, it is assumed that between the brake tests, the holding brake is only correctly used (according to the specifications) and is not used to brake axes that are moving. If an "emergency braking operation" occurred, then organizational procedures must absolutely ensure that before regular operation is resumed, that the brake is thoroughly tested and if required the appropriate service work is carried-out. The precise determination of the DC ("diagnostic coverage") of the braking test essentially depends on the interaction between the test (friction) and the real braking situation – that must be carefully taken into consideration by the user.

In this case, the design of the brake, brake loads and additional mechanical parameters must be carefully taken into consideration, e.g. using the holding brake for several emergency braking operations.

3.3 Probability of failure

3.3.2 Subsystem "fail-safe PROFIsafe I/O"

The properties/features of the sub-system "fail-safe PROFIsafe I/O" (e.g. SIMATIC ET 200S) should be taken from the corresponding manuals of the components that are used (e.g. manual "Distributed ET200S I/O system, fail-safe modules"). Certificates are available for the fail-safe PROFIsafe I/O that are also listed in the Manuals.

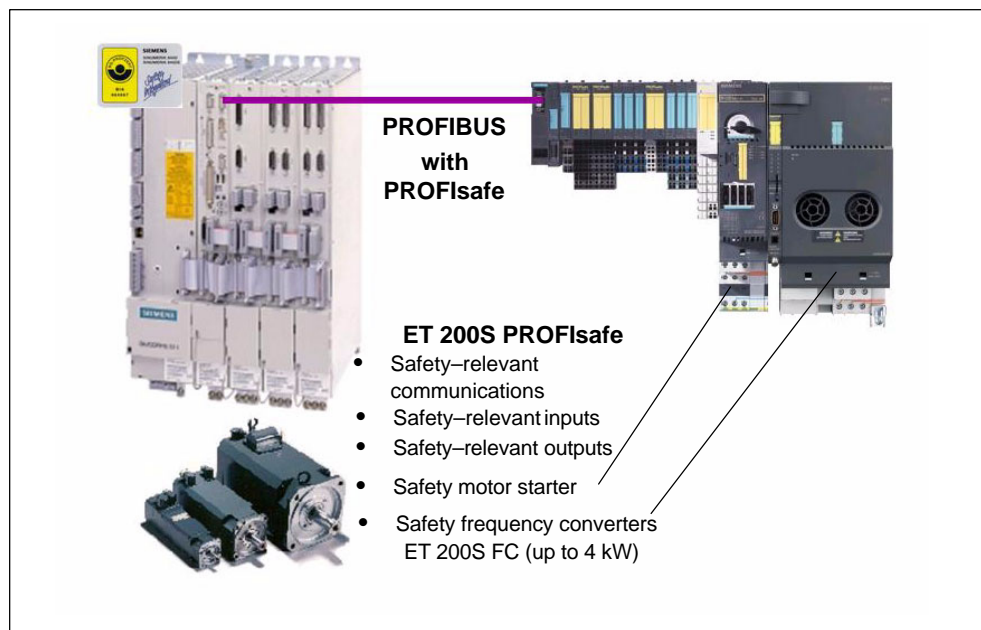

Fig. 3-1 System structure "fail-safe PROFIsafe I/O", for example in this case with SIMATIC ET 200S

3.3.3 Subsystem "Standard SIMATIC/SINUMERIK I/O"

The subsystem "Standard SIMATIC/SINUMERIK I/O" has the following features according to IEC 61508:

- SIL capability: SIL 2
- Mode: "high demand/continuous mode"
- PFH_D ("probability of a dangerous failure per hour"): $2.77 \cdot 10^{-7}/h$
- Maximum total operating time ("mission time"): 10 years

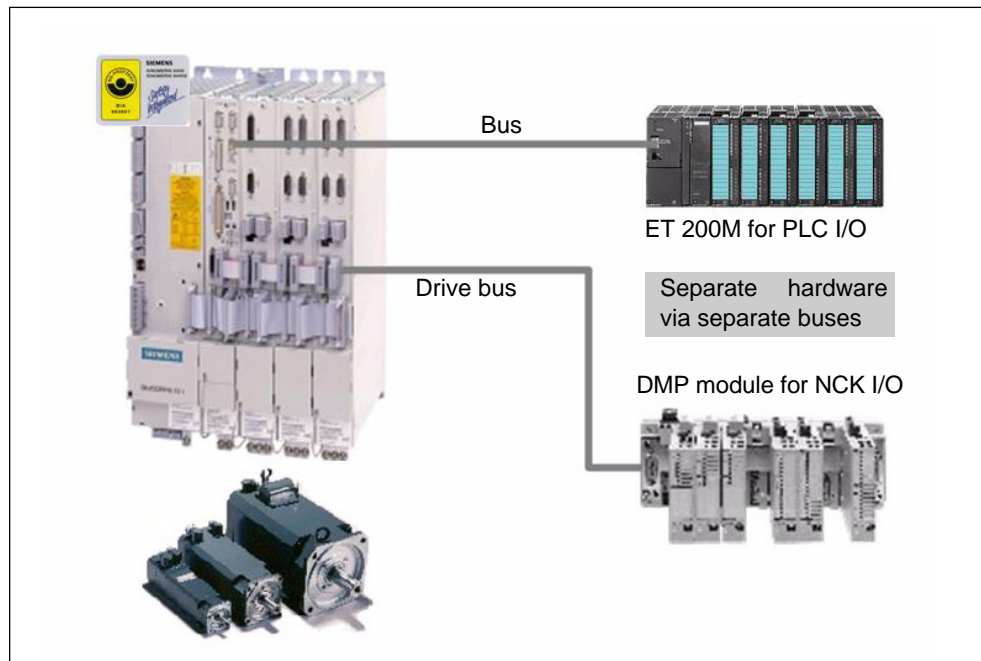

Fig. 3-2 System structure "Standard SIMATIC/SINUMERIK I/O"

Note

The sensor/actuator connection via the sub-system "Standard SIMATIC/SINUMERIK I/O" will no longer be supported or certified at the latest from 2009 onwards.

This is the reason that today we are urgently recommending that only the sub-system "fail-safe PROFIsafe I/O" should be used. This is especially true when engineering new machines and plants or when retrofitting existing machines and plants.

3.4 Residual risks

A fault analysis and probability of failure analysis enables the machine manufacturer to determine the residual risk for his machine with respect to the control. The following residual risks are defined:

- Safety Integrated is not active until the control system and drive have completely run-up. Safety Integrated cannot be activated if any one of the control or drive components is not powered-up. This must be especially taken into account for vertical axes.
- Faults in the absolute track (C–D track), cyclically interchanged phases of motor connections (V–W–U instead of U–V–W) and a reversal in the control direction can cause an increase in the spindle speed or axis motion. Category 1 and 2 Stop functions according to EN 60204–1 (defined as Stop B–E in Safety Integrated) that are provided are however not effective due to the fault. Category 0 stop function according to EN 60204–1 (defined as Stop A in Safety Integrated) is not activated until the transition or delay time set via machine data has expired. When SBR is active, these errors are detected (STOP B/C) and the Category 0 stop function according to EN 60204–1 (STOP A in Safety Integrated) is activated as early as possible irrespective of this delay (refer to Chapter 5.8, "Safe braking ramp"). Electrical faults (defective components etc.) can also result in the response described above.
- When incremental encoders are used, the functions "safe software limit switch" (SE) and "safe software cam" (SN) can only be used after referencing has been successfully completed.
- When no user agreement has been given (refer to Chapter 4.4.3. "User agreement"), the safe software limit switches (SE) are not operative; the safe software cams (SN) are operative, but are not safe as defined by Safety Integrated.
- The simultaneous failure of two power transistors (one in the upper and the other offset in the lower inverter bridge) in the inverter may cause the axis to move briefly.

Example: Synchronous motor:

For a 6-pole synchronous motor, the axis can move by a maximum of 30 degrees. With a ballscrew that is directly driven by, e.g. 20 mm per revolution, this corresponds to a maximum linear motion of approximately 1.6 mm.

Example, synchronous linear motor:

For a synchronous linear motor, the movement can be a maximum of one pole width. This corresponds to the following distances:

1FN1–07 2	7 mm
1FN1–12/–18/–24	36 mm
1FN3	20 mm

- For a 1–encoder system, encoder faults are detected by various HW and SW monitoring functions. It is not permissible that these monitoring functions are de–activated and they must be parameterized carefully. Depending on the fault type and which monitor responds, a Category 0 or Category 1 stop function according to EN 60204–1 (defined as STOP A or B in SINUMERIK Safety Integrated) is activated.
- The Category 0 stop function according to EN 60204–1 (defined as STOP A in Safety Integrated) means that the spindles/axes are not braked to zero speed, but coast to a stop (this may take an appropriately long time depending on the level of kinetic energy involved). This must be included in the protective door locking mechanism logic (e.g. with the logic operation $n < n_x$).
- When a limit value is violated, the speed may exceed the set value briefly or the axis/spindle may overshoot the setpoint position to a greater or lesser degree during the period between the error being detected and the system responding. This depends on the dynamic response of the drive and the parameter settings (refer to Chapter 5, "Safety–Related Functions").
- A position–controlled axis may be forced out of the safe operating stop state (SBH) by mechanical forces that are greater than the max. axis torque. In such cases, a safe standstill (SH) is activated.
- Safety Integrated is not capable of detecting parameterization and programming errors made by the machine manufacturer. The required level of safety can only be assured by thorough and careful acceptance testing.
- Drive power modules and motors must always be replaced with the same equipment type. If this is not the case, the parameters will no longer match the actual configuration – causing Safety Integrated to respond incorrectly. The axis involved must be re–commissioned if an encoder is replaced.
- If, for a 1–encoder system, the encoder signals remain at a steady–state due to an encoder fault (i.e. they no longer following the motion, but have a correct signal level), then when the axis is stationary (e.g. in SBH), this fault is not detected. Generally, the axis is kept at a standstill by the active closed–loop control. Especially for vertical (suspended) axes, from a closed–loop control–related perspective, it is conceivable that such an axis can move downwards without this being detected. For the above mentioned encoder fault, the risk is only possible for a few encoder types as a result of their principle of operation (e.g. encoders with microprocessor–controlled signal generation).

3.5 System prerequisites

3.5.1 General prerequisites

- Software option "SINUMERIK Safety Integrated"
(up to and including software release 6)

Safety Integrated – basic functions for up to 4 axes/spindles	6FC5250-0AC10-0AA0
Safety Integrated – supplementary function from the 5th axis/spindle for each axis/spindle	6FC5250-0AC11-0AA0
Safety Integrated – axis/spindle package for additional 13 axes/spindles	6FC5250-0AC12-0AA0

(from software release 7)

Safety Integrated – basic (incl. 1 axis/spindle, up to 4 SPL I/Os)	6FC5250-0AG00-0AA0
Safety Integrated – comfort (incl. 1 axis/spindle, up to 64 SPL I/Os)	6FC5250-0AG10-0AA0
Safety Integrated axis/spindle (additional for each axis/spindle)	6FC5250-0AG11-0AA0
Safety Integrated – axis/spindle package (additional 15 axes/spindles)	6FC5250-0AG12-0AA0

- SINUMERIK 840 D; all CPU versions may be used
- The measuring circuit cables must comply with the specifications of SIMODRIVE 611digital
- SIMODRIVE 611digital drive converters
Control modules with additional input for a direct measuring system
- The safety-related devices/modules are open-type devices/modules corresponding to UL 50 and in order to provide protection against mechanical damage, they should be accommodated in enclosures/cabinets with degree of protection IP54 according to EN 60529.
- The state of a deleted/clear safety-related input or output (i.e. the state logical "0" of an SGE/SGA and electrical "low" of an associated I/O terminal) or the state of a drive where the pulses are cancelled that can be achieved by the user as well by the fault response of the "SINUMERIK Safety Integrated" system, is defined as the so-called "fail-safe state". This is the reason that the system is only suitable for applications where this state corresponds to the safe state of the process controlled by SINUMERIK Safety Integrated.

Internal NC pulse cancellation

- SINUMERIK software release, minimum 6.3.30

PROFIsafe

- SINUMERIK 840D with NCU 5xx.4 or NCU 5xx.5
- Software option "I/O interface via PROFIBUS-DP"
- SINUMERIK software release \geq 6.3.30
- e.g. SIMATIC ET 200S, ET 200eco fail-safe modules

The following specifically applies for fail-safe SIMATIC modules:

- STEP7 F configuration tool (F Configuration Pack) as supplement to STEP7
This F configuration tool is required so that ET 200S F modules can be integrated into the HW configuration.
The F configuration tool can be downloaded from the A&D Service&Support pages under the **Subject F-Configuration-Pack**. Which F configuration tool can be used for which STEP7 version is also specified there.
When using new ET200S F modules it should be noted that a version of the F configuration tool should be used that already supports the module.
Which modules can be configured with which versions that can be downloaded are also specified in the download area.
- Interrelationship between the NCU system software and STEP7 version NCU system software \geq 06.03.30 and $<$ 06.04.15
Only the STEP7 version 5.1 may be used to generate the STEP7 hardware configuration. The reason for this is that in these NCU system software versions, only the PROFIsafe master address 1 (F-source address) is supported and this is entered in this way via STEP7 version 5.1.
NCU system software \geq 06.04.15
The PROFIsafe master address can be freely configured. The STEP7 hardware configuration can be generated both with STEP7 V5.1 or V5.2 (and higher).

3.5 System prerequisites

Note

STEP7 Version 5.1 is not compatible to STEP7 Version ≥ 5.2 . It is mandatory that this is taken into consideration when configuring the system. This incompatibility lies in how the PROFIsafe master address is entered:

STEP7 V5.1 PROFIsafe master address = 1 (fixed)

STEP7 ≥ 5.2 PROFIsafe master address = PROFIBUS address + offset (2000 and higher)

Further, there is also the interrelationship to the NCU system software mentioned above. If the original project was generated using STEP7 V5.1 and it is then transferred into STEP7 ≥ 5.2 , the the PROFIsafe master address is automatically modified. This means that when a hardware configuration is downloaded again, the associated NCK setting of the PROFIsafe master address must be changed.

In order to avoid incompatibilities and restrictions regarding the software versions, when PROFIsafe is used for the first time, the following software versions should be used:

- NCU system software $\geq 06.04.15$
 - STEP7 Version ≥ 5.2
-

Separate NC and PLC I/O

- NCU terminal block with DMP modules or onboard I/Os of the NCU for the NCK peripherals
 - Simple I/O module (instead of SIMATIC I/O)
(not certified acc. to IEC 61508)
 - SIMATIC S7 I/O modules for the PLC
-

Note

The sensor/actuator connection via the sub-system "Standard SIMATIC/SINUMERIK I/O" will no longer be supported or certified at the latest from 2009 onwards.

This is the reason that today we are urgently recommending that only the sub-system "fail-safe PROFIsafe I/O" should be used. This is especially true when engineering new machines and plants or when retrofitting existing machines and plants.

Prerequisites for SE and SN

- It is no longer possible to set the user agreement using OP 030; this must be realized using a PLC user program.
- No drives with slip.

Limitations/constraints when using the HT6

- It is not possible to "Copy/Acknowledge" the safety machine data from the HT6 handheld terminal. This is only relevant for commissioning.

3.6 Limitations/restrictions (IEC 61508, NFPA 79–2002, NRTL)

3.6 Limitations/restrictions (IEC 61508, NFPA 79–2002, NRTL)

If the SINUMERIK 840D powerline system is operated together with the SINUMERIK Safety Integrated safety functions, and if the operating company demands the certificate according to IEC 61508 or an NRTL Listing to fulfill the requirements of NFPA 79–2002, then the following limitations and restrictions must be carefully complied with.

3.6.1 SINUMERIK 840D NCU – software release

NC software releases from 6.4.15 (inclusive) are certified according to IEC 61508 and are NRTL listed.

3.6.2 SINUMERIK 840D NCU – modules

The following NCU modules are permitted:

Module	Order No.
NCU561.4	6FC5356–0BB14–0AA0
NCU571.4	6FC5357–0BB14–0AA0
NCU572.4	6FC5357–0BB24–0AA0
NCU573.4	6FC5357–0BB34–0AA0
NCU561.5	6FC5356–0BB15–0AA0
NCU571.5	6FC5357–0BB15–0AA0
NCU572.5	6FC5357–0BB25–0AA0
NCU573.5	6FC5357–0BB35–0AA0

3.6.3 SIMODRIVE 611digital – control modules

The following drive control modules are permitted and certified:

Module	Order No.
High–Standard control in a 2–axis version	6SN1118–0DM33–0AA0
High–Standard control in a 2–axis version	6SN1118–0DM33–0AA1
High–Performance control, 1–axis version	6SN1118–0DJ23–0AA0
High–Performance control, 1–axis version	6SN1118–0DJ23–0AA1
High–Performance control, 2–axis version	6SN1118–0DK23–0AA0
High–Performance control, 2–axis version	6SN1118–0DK23–0AA1

3.6 Limitations/restrictions (IEC 61508, NFPA 79–2002, NRTL)

3.6.4 PROFIsafe I/O

There are no additional restrictions when using PROFsafe I/O.

3.6.5 SINUMERIK I/O

The following SINUMERIK I/O modules are certified and permitted for safety–related inputs/outputs:

Module	Order No.
NCU terminal block for 8 DMP compact module	6FC5211–0AA00–0AA0
DMP Compact 16I digital with 16 digital inputs, 24 V DC floating	6FC5111–0CA01–0AA0
DMP compact, 16O digital with 16 outputs 24 V DC/0.5 A, electrically isolated and short–circuit proof	6FC5111–0CA02–0AA2
DMP compact, 8O digital with 8 outputs 24 V DC/2 A, electrically isolated and short–circuit proof	6FC5111–0CA03–0AA2

Additional limitations/restrictions:

- A maximum of 2 NCU terminal blocks are permitted.
- A total of a maximum of 64 safety–related external inputs (SGE) and a maximum of 64 safety–related external outputs (SGA) may be connected to all of the DMP modules used.

Note

The sensor/actuator connection via the sub–system "Standard SIMATIC/SINUMERIK I/O" will no longer be supported or certified at the latest from 2009 onwards.

This is the reason that today we are urgently recommending that only the sub–system "fail–safe PROFIsafe I/O" should be used. This is especially true when engineering new machines and plants or when retrofitting existing machines and plants.

3.6 Limitations/restrictions (IEC 61508, NFPA 79-2002, NRTL)

3.6.6 Standard SIMATIC I/O

The following standard SIMATIC ET 200M modules are permitted for safety-related inputs/outputs:

ET 200M module	Order No.
Interface module IM361	6ES7361-3CA01-0AA0
SM321 digital input, 16 inputs	6ES7321-1BH02-0AA0
SM321 digital input, 32 inputs	6ES7321-1BL00-0AA0
SM322 digital output, 16 outputs, 0.5 A	6ES7322-1BH01-0AA0
SM322 digital output, 32 outputs, 0.5 A	6ES7322-1BL00-0AA0
SM322 digital output, 8 relay outputs	6ES7322-1HF01-0AA0
SM322 digital output, 16 relay outputs	6ES7322-1HH01-0AA0

Additional limitations/restrictions for standard SIMATIC ET 200M modules:

- All standard SIMATIC ET 200M input/output modules that are used for safety-related inputs/outputs (SGE/SGA) may only be inserted in rack 1, 2 or 3 of the SINUMERIK NCU (i.e. not in racks of other SIMATIC-CPU's coupled for example via CPs – or similar)

The following standard SIMATIC ET 200S modules are permitted for safety-related inputs/outputs:

ET 200S module	Order No.
IM151-1 interface module	6ES7151-1AA02-0AB0
IM151-1 interface module	6ES7151-1AA03-0AB0
IM151-1 interface module	6ES7151-1AA04-0AB0
PM-E power module	6ES7138-4CA00-0AA0
PM-E power module	6ES7138-4CA01-0AA0
Electronics module, 4 inputs	6ES7131-4BD00-0AA0
Electronics module, 4 inputs	6ES7131-4BD01-0AA0
Electronics module, 4 outputs 2 A	6ES7132-4BD30-0AA0
Electronics module, 4 outputs 2 A	6ES7132-4BD31-0AA0

3.6 Limitations/restrictions (IEC 61508, NFPA 79–2002, NRTL)

ET 200S module	Order No.
Electronics module, 2 relays	6ES7132-4HB00-0AB0
Electronics module, 2 relays	6ES7132-4HB01-0AB0
Terminal modules	No restrictions

Additional limitations/restrictions for standard SIMATIC ET 200S modules:

- All standard SIMATIC ET 200S input/output modules, that are used for safety-related inputs/outputs (SGE/SGA) may be distributed over a maximum of 3 interface modules. These interface modules must be directly connected to the SINUMERIK NCU via Profibus (i.e. it is not permissible to use repeaters or similar)

General, additional limitations/restrictions for standard SIMATIC modules:

- A total of 64 safety-related external inputs (SGE) and a maximum of 64 safety-related external outputs (SGA) may be connected to all of the standard SIMATIC input/output modules that are being used. It is permissible to mix/combine ET 200M and ET 200S.

Note

The sensor/actuator connection via the sub-system "Standard SIMATIC/SINUMERIK I/O" will no longer be supported or certified at the latest from 2009 onwards.

This is the reason that today we are urgently recommending that only the sub-system "fail-safe PROFIsafe I/O" should be used. This is especially true when engineering new machines and plants or existing machines and plants.

3.6 Limitations/restrictions (IEC 61508, NFPA 79–2002, NRTL)

3.6.7 24 V power supplies that are permitted

For the permissible standard I/O, that is used as SGE/SGA to connect sensors/actuators, the following SITOP power supply units are permitted as power supply:

Module	Order No.
<u>SITOP MODULAR</u> REGULATED LOAD POWER SUPPLY INPUT: 120/230–500 V AC; OUTPUT: 24 V DC/5 A	6EP1333–3BA00
<u>SITOP MODULAR</u> REGULATED LOAD POWER SUPPLY INPUT: 120/230–500 V AC; OUTPUT: 24 V DC/10 A	6EP1334–3BA00
<u>SITOP MODULAR 20</u> REGULATED LOAD POWER SUPPLY INPUT: 3–ph. 400–500 V AC; OUTPUT: 24 V DC/20 A	6EP1436–3BA00
<u>SITOP MODULAR 40</u> REGULATED LOAD POWER SUPPLY INPUT: 3–ph. 400–500 V AC; OUTPUT: 24 V DC/40 A	6EP1437–3BA00
<u>SITOP POWER DC UPS MODULE 24 V/15 A</u> WITH USB INTERFACE; INPUT 24 V DC/16 A; OUTPUT 24 V DC/15 A	6EP1931–2EC41
<u>SIMATIC S7–300. LOAD POWE SUPPLY PS 307</u> 120/230 V AC; 24 V DC, 5 A	6ES7307–1EA00–0AA0

Additional limitations/restrictions

- All standard I/O components that are used for safety–related inputs/outputs (SGE/SGA) must be operated with these power supply units.
 - SINUMERIK NCU terminal block with DMP I/O modules
 - NCU onboard I/O (X121 interface at the NCU)
 - SIMATIC I/O modules
- Further, all of the standard I/O components that are used as 3rd or 4th terminal for the 3– or 4–terminal concept of safety–related inputs/outputs (SGE/SGA) must be operated with these power supply units.
 - SIMATIC I/O modules
- If the sensor/actuator, connected to the safety–related inputs/outputs (SGE/SGA) has its own power supply connection, then this must also be operated with these power supply units.
- Only one power supply unit may be used for the standard safety–related I/O. When selecting this power supply unit, it is important to note that the power supply unit can also provide the total current of the safety–related I/O.
- The sensors/actuators connected to the safety–related inputs/outputs (SGE/SGA) must be designed so that the maximum operating voltage of 35 V, which can occur under fault conditions, cannot result in any undefined behavior of the controlled process.

3.6 Limitations/restrictions (IEC 61508, NFPA 79–2002, NRTL)

Note

The above listed limitations/constraints of the standard I/O do not apply for PROFsafe I/O and the sensors/actuators connected to them.

Note

The sensor/actuator connection via the sub–system "Standard SIMATIC/SINUMERIK I/O" will no longer be supported or certified at the latest from 2009 onwards.

This is the reason that today we are urgently recommending that only the sub–system "fail–safe PROFsafe I/O" should be used. This is especially true when engineering new machines and plants or when retrofitting existing machines and plants.

3.6.8 Additional limitations/restrictions in order to fulfill NFPA 79–2002

If the SINUMERIK 840D powerline system is operated together with the SINUMERIK Safety Integrated safety functions, and if the operating company requires an NRTL Listing to fulfill the requirements of NFPA 79–2002, then the following limitations/restrictions must be carefully observed.

If only a certificate according to IEC 61508 is required, then the following limitations/restrictions do not have to be observed.

NFPA 79–2002 specifies, for an Emergency Stop function, that the electrical power is disconnected using electromechanical equipment as final measure (NFPA 79–2002, 9.2.5.4.1.4: "The final removal of power shall be accomplished by means of electromechanical components".).

The user himself must fulfill this requirement by appropriately engineering the application.

Basic Procedures and Mechanisms

4.1 Monitoring clock cycle

Setting the monitoring clock cycle time

The safety-related functions are monitored cyclically in the monitoring clock cycle that can be set jointly for all axes/spindles using the following machine data:

Setting the monitoring clock cycle time

for 840D

MD 10090: \$MN_SAFETY_SYSCLOCK_TIME_RATIO

The specified clock cycle is checked and rounded-off to the next possible value when the control runs-up and every time the machine data changes.

The resulting monitoring clock cycle is displayed using MD 10091:

\$MN_INFO_SAFETY_CYCLE_TIME

(refer to Chapter 6.1 "Machine data for SINUMERIK 840D").

for 611digital

MD 1300: \$MD_SAFETY_CYCLE_TIME

(refer to Chapter 6.2 "Machine data for SIMODRIVE 611 digital")



Warning

The monitoring clock cycle determines the response time of the safety-related functions. It must therefore be selected to be ≤ 25 ms. The higher the monitoring cycle setting, the greater the amount by which the monitored limit value is violated in the event of an error and the more that the drive(s) overshoots.

4.2 Crosswise data comparison

Dormant errors in the safety-related data of the two monitoring channels are detected by the crosswise data comparison.

In the case of "non-steady-state" data, tolerance values defined using machine data are used by which amount the results of the two channels may deviate from one another without initiating a response (e.g. tolerance for crosswise data comparison of actual positions).

A distinction is made between:

- Crosswise data comparison between the NC and drive
- SPL crosswise data comparison between the NC and PLC

Error response

If the crosswise data comparison identifies an error, then this results in a stop response (refer to Chapter 5.1.5).

Crosswise data comparison error	(NC + drive)	with Stop F
SPL crosswise data comparison error	(NC + PLC)	with Stop D or E

In addition, safety alarms are output.

Displays the crosswise data comparison clock cycle

The MD 10092: \$MN_INFO_CROSSCHECK_CYCLE_TIME specifies the maximum crosswise comparison clock cycle in seconds. If the monitoring clock cycle is modified, then the crosswise comparison clock cycle is also changed.

In order to be able to support the different function configurations (expansions) of the various control modules, the amount of data that is compared crosswise between the NCK and 611digital monitoring channel differs depending on the specific axis. To display the actual crosswise data comparison cycle time, the axial MD 36992: \$MA_SAFE_CROSSCHECK_CYCLE is used.

4.3 Forced checking procedure

Forced checking procedure, general (extract from /6/)

"...A forced checking procedure must be carried-out for all static (steady-stage) signals and data. Within the required time (8 h), the state must change from a logical 1 to a logical 0 – or vice versa. If the state remains static in a fault situation, then this is detected at the latest as a result of this forced checking procedure and the subsequent comparison.

A forced checking procedure must be used, e.g. for components that are required to stop a process (e.g. contactors and power semiconductors) – the so-called shutdown path and for the shutdown condition. Generally, it is not possible to test a shutdown condition, e.g. violation of a limit value criterion, using other methods such as e.g. crosswise data comparison, when the machine is in an acceptable (good) condition. This also applies to errors along the entire shutdown path including associated hardware and software and circuit-breakers.

By integrating a test stop every eight hours with a comparison and expected status, faults can also be detected when the machine is in an acceptable (good) condition...."

(Comment: Acceptable (good) condition means that there are no machine faults that are apparent to the operator).

Forced checking procedure with Safety Integrated

The forced checking procedure is used to detect faults/errors in the software and hardware of the two monitoring channels. In order to do this, the safety-related parts in both channels must be processed at least once during a defined period in all safety-related branches. Any faults/errors in the monitoring channel would cause deviations and will be detected by the cross-wise data comparison.

The forced checking procedure of the shutdown path (test stop) must be triggered by the user or integrated in the process as an automatic procedure, e.g.:

- When the axes are stationary after the system has been powered-up
- When the protective door is opened
- In defined cycles (e.g. every 8 hours)
- In the automatic mode, dependent on the time and event.

The forced checking procedure also includes testing the safety-related sensors and actuators at the safety-related inputs/outputs. In this case, the entire circuit including the "safe programmable logic" (SPL) is tested to ensure that it is correctly functioning (refer to Chapter 5.10.12 "Forced checking procedure of SPL signals").

4.3 Forced checking procedure

Note

The test interval duration of 8 hours may only be extended under the following conditions:

- In the time after the test interval has expired, no hazards for personnel may occur – the must be excluded complete (e.g. the protective door is closed and is also interlocked)
- After the test interval has expired, before a possible hazard to personnel (e.g. for a request to open a protective door), a test stop or a forced-checking procedure must be carried-out to absolutely ensure the availability of the shutdown paths and the safety-related inputs/outputs.

This means that for the duration of the automatic mode (with the protective door closed and interlocked), the fixed 8-hour cycle isn't strictly specified. When the 8 hours expires, in this case, the forced-checking procedure can be linked to the next time that the protective door is opened.

Note

Errors that are detected as a result of the forced checking procedure or crosswise data comparison lead to a STOP response (refer to Chapter 5.1.5 "Stop responses") and initiate a further stop response when safety integrated is active.

4.4 Actual value conditioning

4.4.1 Encoder types

Basic types

The following basic encoder types can be used with a drive module to implement safety-related operation:

- Incremental encoder
with sinusoidal voltage signals A and B (signal A is shifted with respect to B through 90° and a reference signal R, e.g.: ERN 1387, LS 186, SIZAG2
- Absolute encoder
with an EnDat interface and incremental sinusoidal voltage signals A and B (signal A is shifted with respect to B through 90°), e.g.: EQN 1325, LC 181

Combining encoder types

Various combinations can be derived from the basic types.

Table 4-1 Combining encoder types

Incremental encoders		Absolute encoders		Comments
at the motor	at the load	at the motor	at the load	
x				1–encoder system
		x		1–encoder system
	x	x		2–encoder system
x	x			2–encoder system
x			x	2–encoder system
		x	x	2–encoder system
Note: x -> encoder connection				

1–encoder system

For a 1–encoder system, the incremental or absolute encoder of the motor is used for the safety-relevant actual values of the NC and drive.

The 611digital control module supplies one actual value to the NCK and the drive through 2 separate actual value channels.

Special feature regarding linear motors:

For linear motors, the motor encoder (linear scale) is also the measuring system at the load. IMS and DMS are one measuring system. The connection is made at the

4.4 Actual value conditioning

IMS input of the 611 digital control module.

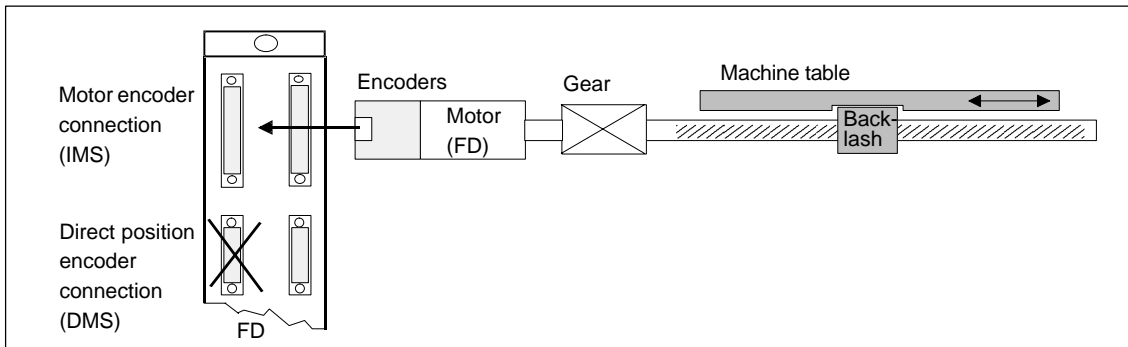

Fig. 4-1 1-encoder system for a feed drive (FD)

Note

For a 1-encoder system, a direct position encoder (DMS) cannot be used for the measuring system of another axis.

2-encoder system

In this case, the actual values for an axis are supplied from 2 separate encoders. In standard applications, the drive evaluates the motor encoder and the NC, for example, the measuring system connected to the second actual value input. The 611 digital control module transfers the two actual values to the NCK and drive through 2 separate actual value channels.

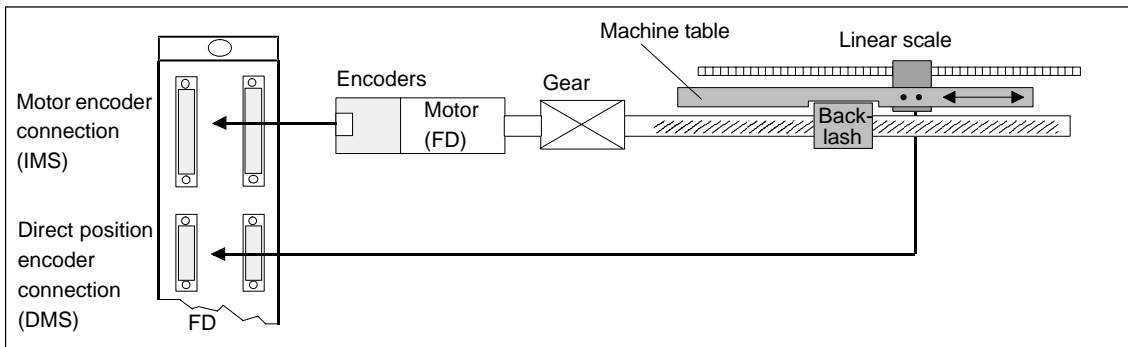

Fig. 4-2 2-encoder system for a feed drive (FD)

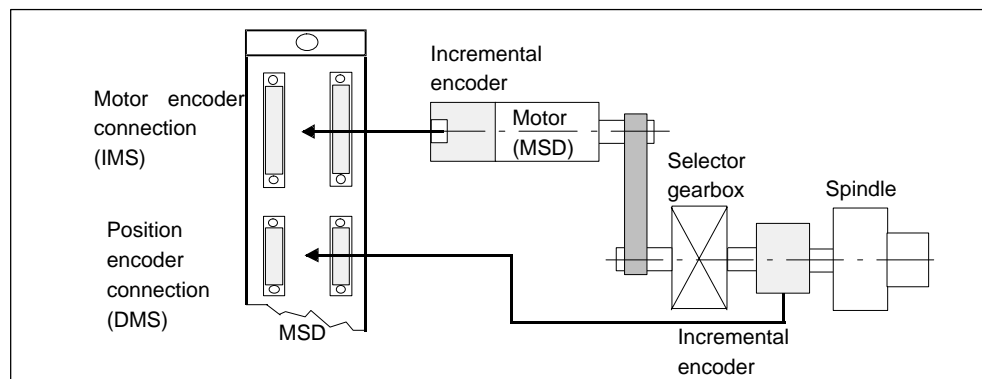

Fig. 4-3 2-encoder system for a main spindle

Note

If the ratio of the gearbox located between the motor and load is not slip-free, the 1-encoder system must be selected. The 2nd spindle encoder is connected to another drive module through an actual-value input. In this particular case, SE and SN are not possible (refer to Chapter 10.16 "Application: Spindle with 2 encoders and drive with slip").

Systems with slip are also possible (refer to Chapter 4.4.7).

4.4.2 Encoder adjustment, calibrating the axes

Adjusting the motor encoder

Generally, for 1-encoder systems, the integrated encoder is an integral component of the motor (the encoder is adjusted to match the motor). Data relating to distance, speed and rotor position (for synchronous drives) is obtained from one encoder. It is no longer possible to adjust the encoders in motor measuring systems in the conventional sense.

Calibrating the machine

The machine zero and encoder zero are calibrated purely on the basis of the offset value (the machine must be calibrated). This procedure must be carried-out for both absolute and incremental encoders.

4.4 Actual value conditioning

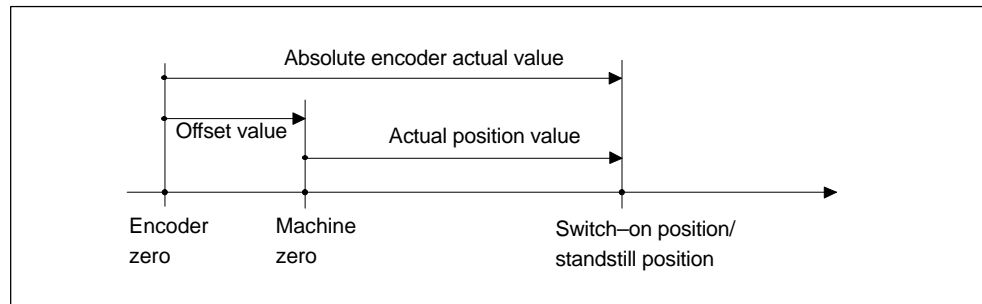

Fig. 4-4 Positions and actual values

When calibrating the machine, a known or measured position is approached using a dial gauge, fixed end stop, etc. and the offset determined. This offset is then entered into the appropriate machine data. Calibration must always be carried-out for position-controlled (closed-loop) axes/spindles.

Reference: /IAD/, Commissioning Manual SINUMERIK 840D
/FBD/, Description of Functions, SINUMERIK 840D,
R1, "Reference point approach"

4.4.3 User agreement

Description

With a user agreement, an appropriately authorized person confirms that the currently displayed SI actual position of an axis corresponds to the actual position at the machine.

This can be checked by traversing the axis to a known position (e.g. a visual mark) or the axis is adjusted/calibrated and the SI actual position is therefore compared in the "user agreement" screen.

An axis/spindle with integrated safety functions can have the following status:

User agreement = yes, or

User agreement = no

The following data for each axis/spindle with activated Safety Integrated is displayed in the "user agreement" screen:

- Machine-axis name
 - SI position
 - User agreement

When does a user agreement have to be given?

A user agreement is only required when "safe software limit switches" (SE) and/or "safe software cams" (SN) are being monitored for an axis/spindle, i.e.

- when the axis/spindle is commissioned for the first time.
- when the user intends or needs to again manually and safely reference the axis/spindle.
- if, after POWER ON, the standstill position did not correspond with the actual position and the control cancelled the user agreement.
- after parking an axis/spindle
(only if the change in position is greater than that defined using MD 36944: Tolerance actual value comparison (referencing)).

For additional information on the user agreement, refer to Chapter 4.4.4 "Axis states"

Note

An axis/spindle must have the status User agreement = yes before the SN and SE functions can be used.

For axes/spindles without the safety "SE" and "SN" functions, the saved standstill (zero-speed) position is not evaluated if a user agreement has not been set.



Warning

If the drive is not reliably referenced and a user agreement has not been given, then the following applies:

- The "safe software cams" are active but not safe in the sense of control Class 3.
 - The "safe software limit switches" are not active.
-

Interlocking the user agreement

Before a user agreement can be issued, the interlock must be cancelled:

- Key-operated switch
in setting 3 → the user agreement can be issued

After the user agreement has been issued, the interlocking must be again set (e.g. the key withdrawn).

4.4 Actual value conditioning

4.4.4 Axis states

"Axis not referenced" state

The axis state "axis not referenced" is reached after the power supply has been powered-up and the drive and control system have completely run-up. This state is indicated using the axis-specific interface signal "reference point reached" as follows:

Interface signal

"Reference point reached" = "1" Axis state "Axis referenced"

"Reference point reached" = "0" Axis state "**Axis not referenced**"

For 840D DB31-48, DBX60.4/DBX60.5

The function SBH/SG can only be used when this state has been reached (after run-up has been completed)

(refer to Fig. 4-5 "Axis states when referencing")

"Axis referenced" state

For **incremental encoders**, the position actual value is lost when the NC is powered-down. When the NC is powered-up, a reference point approach must be carried-out. If this is executed correctly, then the axis is referenced and goes into the "axis referenced" state (refer to 4-5 "Axis states when referencing").

Contrary to incremental encoders, **absolute encoders** do not require a reference point approach after the NC has been powered-up. These encoders track the absolute position, e.g. using a mechanical gear, both when powered-up and powered-down. The absolute position is transferred implicitly via a serial interface when the NC is powered-up. After the position data has been transferred and the offset value has been taken into account, the axis also goes in the axis state "axis referenced" (refer to Fig. 4-5 "Axis states when referencing").

This axis state "axis referenced" is indicated using the axis-specific interface signal "reference point reached" as follows:

Interface signal

"Reference point reached" = "1" Axis state "**Axis referenced**"

"Reference point reached" = "0" Axis state "Axis not referenced"

For 840D DB31-48, DBX60.4/DBX60.5

Reference: /IAD/, Commissioning Manual, SINUMERIK 840D

"Axis safely referenced" state

In order to reach the axis state "axis safely referenced", the axis state "axis referenced" must have been reached, and either

- The user confirms/acknowledges the current position using the user agreement or
- Historical data (saved and set user agreement and a saved stop position when the system is powered-down) must exist. The position associated with the historical data must match the current position within a tolerance window. This is checked both in the drive and in the NC.

The axis state "axis safely referenced" is displayed using the SGA "axis safely referenced". A safety-related position evaluation can only be carried-out for the SE and SN functions after this state has been reached (refer to Fig. 4-5 "Axis states when referencing").

User agreement

The user agreement function (protected using a key-operated switch) allows the user to confirm that the current position at the machine corresponds to the position displayed in the NC.

The user agreement is entered using a soft key. Before this can be done, the axis state "axis referenced" must have been reached. If the axis is in this state and the user has confirmed the position by means of the agreement function, then the axis state "axis safely referenced" is reached.

If the user agreement has been set without the axis being in the "axis referenced" state, then Alarm 27001 "Defect in a monitoring channel" is output with fault code 1004.

The user agreement can only be set by an authorized user.

The user agreement can be cancelled by the user or as a result of a function being selected (e.g. new gear stage) or also an incorrect state (e.g. inconsistency in the user agreement between the NC and drive). When the user agreement is cancelled, the axis state "axis safely referenced" is always reset (refer to Fig. 4-5 "Axis states when referencing").

Saved user agreement

The state of the user agreement function is saved in non-volatile memories. This agreement data constitutes the previous history in combination with the standstill position data that is also saved in a non-volatile fashion.

4.4 Actual value conditioning

Saved standstill position

The saved standstill position data is combined with the permanently saved user agreement to form the previous history.

The following must be noted when the standstill position is saved:

- The standstill position is saved when a safe operating stop (SBH) is selected using the SGE "SBH/SG de-selection".
- The following applies when SE/SN is active:
The standstill position is also cyclically saved.
- If the axis is moved with the system powered-down, then the saved standstill position no longer matches the current position.

History

Historical data comprises the saved user agreement and the saved standstill position (refer to "Saved user agreement" and "Saved standstill position").

As described under "Axis safely referenced", historical data can be used to obtain the axis state "axis safely referenced".

The following conditions must be fulfilled:

- The saved user agreement must be available.
- The difference between the "reference position" (power-on position with absolute measuring systems or reference position for incremental measuring systems) and the saved standstill position (including the traversing distance to the reference point with ERN) must be within a tolerance window specified using the appropriate machine data.

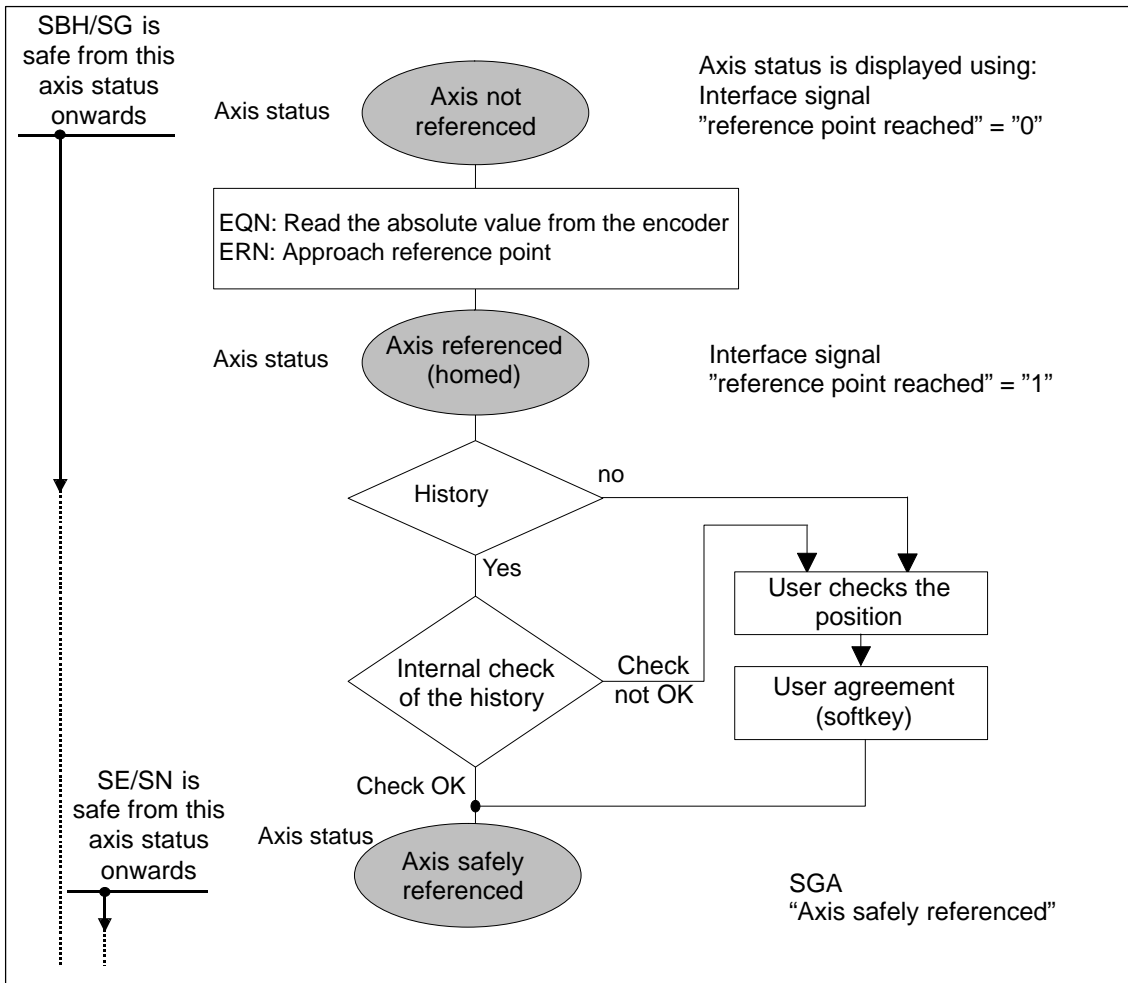

Fig. 4-5 Axis states when referencing

4.4.5 Overview of the data for mounting encoders

Overview of MD for 840D

Table 4-2 Overview of machine data for 840D

Number	Identifier
36910	\$MA_SAFE_ENC_SEGMENT_NR
36911	\$MA_SAFE_ENC_MODULE_NR
36912	\$MA_SAFE_ENC_INPUT_NR
36915	\$MA_SAFE_ENC_TYPE
36916	\$MA_SAFE_ENC_IS_LINEAR
36917	\$MA_SAFE_ENC_GRID_POINT_DIST

4.4 Actual value conditioning

Table 4-2 Overview of machine data for 840D

Number	Identifier
36918	\$MA_SAFE_ENC_RESOL
36920	\$MA_SAFE_ENC_GEAR_PITCH
36921	\$MA_SAFE_ENC_GEAR_DENOM[n]
36922	\$MA_SAFE_ENC_GEAR_NUMERA[n]
36925	\$MA_SAFE_ENC_POLARITY
Note: Data is described in Chapter 6.1, "Machine data for SINUMERIK 840D"	

Overview of MD for 611digital

Table 4-3 Overview of machine data for 611digital

Number	Identifier
1316	\$MD_SAFE_ENC_CONFIG
1317	\$MD_SAFE_ENC_GRID_POINT_DIST
1318	\$MD_SAFE_ENC_RESOL
1320	\$MD_SAFE_ENC_GEAR_PITCH
1321	\$MD_SAFE_ENC_GEAR_DENOM[n]
1322	\$MD_SAFE_ENC_GEAR_NUMERA[n]
Note: Data is described in Chapter 6.2, "Machine data for SIMODRIVE 611digital"	

4.4.6 Taking into account selector gearboxes

The possible gearbox ratios must be known in order that the NC and drive can evaluate the position actual values referred to the load.

For this purposes, various gearbox ratios can be selected on an axis-for-axis basis in the machine data and selected using the "safety-related inputs/outputs" (SGEs/SGAs).

The following points must be carefully observed for drives with selector gearboxes (these are generally used with spindles).

- If the drive is operated with an (indirect) encoder (motor measuring system), i.e. the safety-related actual value for the NCK and drive are derived from the same measuring system, then the gearbox ratios (gearbox stage selection for Safety Integrated), must also be selected for both monitoring channels. The state of the SGE signal ratio selection (bits 0..2) is not subject to a crosswise data comparison; however, the safety-related actual values from the NCK and

drive are compared to evaluate if there is any deviation ($< MD\ 36942\ \$MA_SAFE_POS_TOL$ and $MD\ 1342\ \$MD_SAFE_POS_TOL$).

- If the drive is operated with an (indirect) motor encoder and a (direct) spindle encoder, the safety-related actual values are taken from the NCK (direct encoder) and drive (indirect encoder). For the direct encoder, the gearbox changeover is not relevant and the gearbox stage changeover only has to be configured/engineered for the drive.
- Using the two machine data fields
 $MD\ 36921[0..7]\ \$MA_SAFE_ENC_GEAR_DENOM[n]$ denominator, gearbox ratio encoder/load and
 $MD\ 36922[0..7]\ \$MA_ENC_GEAR_NUMERA[n]$ numerator, gearbox ratio encoder/load
 or
 $MD\ 1321[0..7]\ \$MD_SAFE_ENC_GEAR_DENOM[n]$ denominator, gearbox ratio encoder/load and
 $MD\ 1322[0..7]\ \$MD_ENC_GEAR_NUMERA[n]$ numerator, gearbox ratio encoder/load,
 8 different gearbox stage pairs for NCK/drive can be defined. For this definition, there is no special function for an index value – e.g. interdependency on the operating mode of the spindle. These 8 pairs must be parameterized and selected depending on the encoder configuration.
- As a result of the gearbox stage changeover, the encoder evaluation for the safety-related actual values change. Ideally, the gearbox stage for Safety Integrated is changed-over at standstill. However, this is generally not in-line with what is required in practice. This means that the actual value offset when changing-over the gearbox stage (e.g. using oscillation) may not be greater than the already mentioned actual value tolerance window ($MD\ 36942/MD\ 1342$).
- If, for the axis with selector gearbox, position-dependent monitoring functions are activated – such as SE or SN – the user agreement (assuming that it was previously set) is withdrawn when changing-over the gearbox ratio and the SGA "axis safely referenced" is set to 0. When the gearbox stage is changed from the PLC and/or by selecting a new ratio, a new gearbox ratio is detected using the appropriate SGEs.
- After the gearbox stage has been selected, the spindle must be re-synchronized. When re-synchronizing the spindle, the two safety-related actual values (NCK and drive) are re-initialized with the newly synchronized actual value. A possible difference that was previously present between the two safety-related actual values is therefore corrected.
- In order to be able to re-use the SN or SE function after the gearbox ratio has been selected (changed), the user must bring the spindle into the state "axis safely referenced" – the user agreement must be re-issued.
- For 2-encoder systems, the gearbox ratio does not have to be selected in a safety-related fashion and can be implemented through one channel. On the other hand, for a 1-encoder system, the ratio selection must be implemented using safety-related technology – i.e. using two channels.

4.4 Actual value conditioning

Note

When a new stage is selected for a selector gearbox (the ratio changed), an axis is parked or the mounting situation is modified (encoder and motor replaced), this means that the load and encoder have been de-coupled. The NC and drive cannot detect this. The state "axis safety referenced" is no longer applicable. The user is responsible in bringing the axis back into the "axis safely referenced" state if the functions "safe software limit switch" or "safe cams" are used.

4.4.7 Actual value synchronization (slip for 2-encoder systems)

Description of the function

When a 2-encoder system is used, SI actual values from the NC and the drive drift apart for systems that have inherent slip. The reason for this is that the drive evaluates the motor measuring system and the NC evaluates the direct measuring system after the gearbox.

This offset is detected by the crosswise data comparison and a stop response is triggered. In the case of axis drives with variable coupling factors (slip or belt drive), up until now it was necessary to use a 1-encoder system to prevent the SI actual values of the NC and drive from drifting apart.

If a direct measuring system was required for position control, up until now, it was necessary to use an additional 611digital module to sense the actual value. To avoid this, a solution using a 2-encoder system with slip has now been implemented in the software.

Slip tolerance

In order to define the slip tolerance, the maximum input value is set in MD 36949 \$MA_SAFE_SLIP_VELO_TOL. As a result of an action, such as e.g. maximum acceleration when starting, gearbox stage changes with oscillation, a situation is created where the actual values drift apart. This value can be taken as nominal value from the diagnostics screen (maximum speed difference), multiplied by a factor of 1.5 and then entered into MD 36949.

The actual value is synchronized through two channels. Machine data \$MA_/\$MD_SAFE_SLIP_VELO_TOL is introduced into both channels and the maximum offset between the NCK and drive actual value is entered into it as a speed. This machine data is converted into an internal format and is used as the actual value tolerance for the crosswise comparison. The tolerance value entered in MD 36949: \$MA_SAFE_SLIP_VELO_TOL is not relevant, as only the "new" tolerance value is taken into account in the crosswise data comparison.

For the actual value synchronization, both channels correct their SI actual position to half the determined actual value difference. Please note that the two SI actual positions no longer display the correct absolute position. The NC actual position and the two SI actual positions are different.

In addition to the load-side actual value, the motor-side actual position is also corrected. This ensures that the corrected actual value remains active in subsequent monitoring cycles until the next synchronization.

The actual values are synchronized in the crosswise data comparison clock cycle. Actual values are also synchronized when a crosswise data comparison of the SI actual position outputs an error. This has the advantage that Alarms 27001/300911 can be acknowledged and do not immediately re-appear.

Actual values are also synchronized after "referencing" and for "parking axis".

The currently determined and the maximum SI speed difference since the last reset are displayed in the axis-specific service screen for diagnostic purposes.

Note

Actual values are only synchronized when there is an actual value difference between the two channels of 2 μm or 2 mDegrees in each SI monitoring clock cycle.

Limitations/constraints

The two SI actual positions no longer display the correct absolute machine position. The correct position can now only be read-out via the NC actual position.

The safety monitoring functions SG, SBH, SBR and " $n < n_x$ " still only respond to actual value changes from the particular actual value acquisition channel – not to changes in the actual value resulting from the actual value synchronization. A single-channel SG violation only triggers an alarm in the channel in which this speed violation was detected. The associated stop response is therefore still initiated through two channels.

SGA " $n < n_x$ " can also assume different static states in the two monitoring channels.

Note

It is not possible to activate the safe SE and SN functions for an axis/spindle where slip can occur between the motor and the load.

4.4 Actual value conditioning

Activating

Actual value synchronization is selected by setting bit 3 in MD \$MA_/\$MD_SAFE_FUNCTION_ENABLE. In addition, SI function "SBH/SG monitoring" must also be enabled.

Actual value synchronization is only permissible if a monitoring function with absolute reference has not been enabled. If SE and/or SN are also selected, power on Alarms 27033 and 301708 are also output during power on.

This means that actual value synchronization is only permitted for SBH/SG axes, as in this case, the absolute position is not required. Further, actual value synchronization is only permitted for two–encoder systems. If this function is enabled for a single–encoder system, Alarm 27033 is output.

4.4.8 Encoder limit frequency

For safety–related operation, it is not permissible that the encoder limit frequency is exceeded.

For this purposes, Safety Integrated monitors for the encoder limit frequency being exceeded depending on the situation (depending on the context); when the encoder limit frequency is exceeded, an appropriate alarm is output (refer to Chapter 5.5 "Safely–reduced speed").

4.5 Enabling the safety-related functions

Global enable

SINUMERIK Safety Integrated[(SI) with the safety-related functions is enabled using options.

The enable signal determines the number of axes/spindles for which SI can be activated. From software release 7 onwards, in addition, the number possible SPL-SGE/SGAs is defined.

The SH function is operative if at least one safety-related function is activated.

Enabling safety-related functions

Which safety functions are to be effective can be individually selected for each axis using the following machine data:

for 840D

MD 36901: \$MA_SAFE_FUNCTION_ENABLE

(refer to Chapter 6.1 "Machine data for SINUMERIK 840D")

for 611digital

MD 1301: \$MD_SAFE_FUNCTION_ENABLE

(refer to Chapter 6.2 "Machine data for SIMODRIVE 611 digital")

Among others, the following functions can be individually enabled:

- SBH/SG
- SE
- SN1+ , SN1 –, SN2 +, SN2 –, SN3 +, SN3 –, SN4 +, SN4–
- SG override
- Actual value synchronization
- External STOPs
- Cam synchronization
- STOP E (since SW 6.4.15)

4.6 Switching the system on/off

Note

- To ensure that SBH can always be selected in the event of an error, the function SBH/SG must be activated and appropriately parameterized when the function SE and/or SN are(is) enabled.
 - The axis-specific enable data in the NCK must match those in the drive, otherwise, the crosswise data comparison signals an error.
 - An SI axis is treated as an axis in terms of the global option if at least one safety-related function is activated via the axis-specific enable data.
 - The maximum number of axes that may operate with SI and SPL SGE/SGAs is the number that was enabled using the options.
-

4.6 Switching the system on/off



Warning

After hardware and/or software components have been changed or replaced, it is only permissible to run-up the system and activate the drives when the protective devices are closed. Personnel may not be in the hazardous area.

Depending on the change made or what has been replaced, it may be necessary to carry-out a partial or complete acceptance test (refer to Chapter 7.2 "Acceptance report").

Before persons may re-enter the hazardous area, the drives should be tested to ensure that they exhibit stable behavior by briefly moving them in both the plus and minus directions (+/-).

What has to be observed when powering-up?

The safety-related functions are only available and can be activated after the system has completely run-up.

We recommend that the "safe operating stop (SBH)" function is selected.



Warning

When the system runs-up, this represents a critical operating state with increased risk. In this phase, especially when activating drives, it is not permissible that personnel are close to the hazardous area.

Further, for vertical axes, it is very important to ensure that the drives are in a state with the pulses cancelled.

We recommend a complete forced checking procedure after powering-up (refer to Chapter 5.1.3, "Testing the shutdown paths").

What has to be observed when powering-down?

- For axes with safety functions, the standstill position is saved in a non-volatile fashion when the safe operating stop (SBH) is selected. For axes with SE/SN, the standstill position is used to internally check the position when powering-up.
- The following applies when SE/SN is activated:
The standstill position is also cyclically saved.
This is the reason that users should only power-down the control when axes/spindles with safety functions are at a standstill.

Note

If the axis is moved with the system powered-down, then the saved standstill position no longer matches the current position. For axes with safety SE and SN functions, when powering-up, a user agreement is again required after the position has been checked.

Safety-Related Functions

5.1 Basic mechanisms of SI functions

The safety-related functions are available in all of the operating modes and can communicate with the process via safety-related input/output signals. They fulfill the requirements of safety Category 3 (acc. to EN 954-1) or SIL 2 (acc. to IEC 61508).

5.1.1 Safe standstill – disconnecting the energy feed

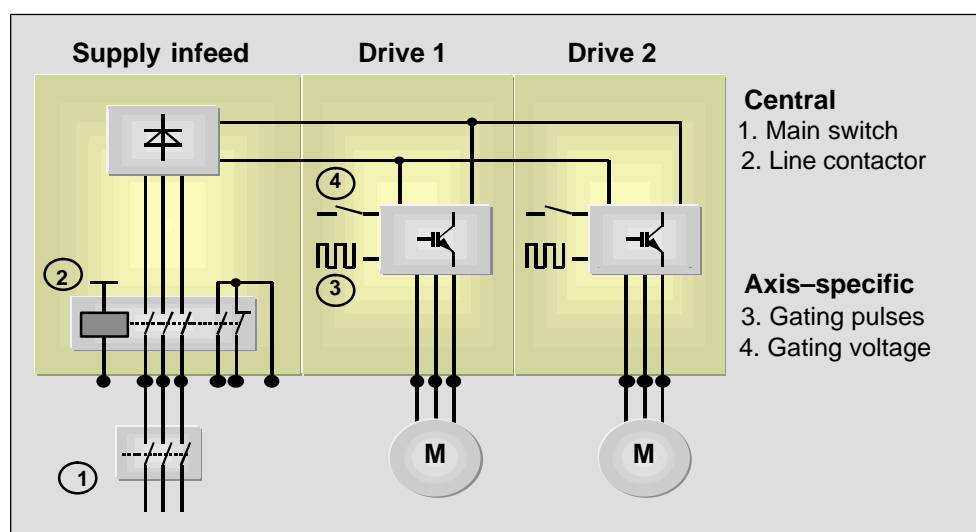

Fig. 5-1 Safe standstill – disconnecting the energy feed

The 4 basic possibilities of switching a motor into a torque-free condition are shown in Fig. 5-1. These have different modes of operation.

① Main switch: Mode of operation → central

Every machine must be equipped with at least one switch. This allows the system to be completely electrically isolated from the line supply (STOP A). This is generally implemented using the main switch. This measure provides protection against electric shock when working on parts and components that are generally live. When in the off position, the switch must be locked to prevent accidental starting.

5.1 Basic mechanisms of SI functions

- ② Integrated line contactor: Mode of operation → central

Using the line contactor in the infeed module, the complete drive converter can be electrically isolated from the line contactor. When referred to the drive converter this measure also corresponds to a STOP A. In the past, using the integrated line contactor, for an Emergency Stop, the drive converter/motor was brought into a torque-free condition in conjunction with a STOP B/C. However, for an Emergency Stop, electrical isolation is not absolutely necessary.

- ③ Canceling pulses in the gating unit Mode of operation → axis-specific

The fastest way of switching a drive axis-for-axis into a torque-free condition is to cancel the pulses via the gating unit. However, this measure is still not safety-related. This does not allow electrical isolation between the drive converter DC link (600 V) and the motor.

- ④ Control voltage of the opto-coupler Mode of operation → module-specific

When the opto-coupler control voltage is switched-out, this means that when a fault condition exists, gating unit pulses cannot be converted into a torque in the drive power module. This does not allow electrical isolation between the drive converter DC link (600 V) and the motor. This is also not necessary for "functional safety".

The measures under ④ can be controlled through two channels physically decoupled from the drive and the NC. It represents an effective and safe possibility of canceling the drive converter pulses on a module-for-module basis and is integrated in the cyclic test (forced checking procedure). The requirements for Emergency Stop are fulfilled. It is no longer absolutely necessary to de-energize (open) the line contactor.

When working on live (undervoltage) parts and components (e.g. service, maintenance,...), it is always necessary to electrically isolate the equipment from the line supply.

5.1.2 Shutdown paths

Shutdown paths for pulse cancellation

The drive pulses must be cancelled through two channels. In this case, the machinery construction OEM must configure a shutdown path in the NCK monitoring channel and a shutdown path in the drive monitoring channel.

(Refer to Fig. 5-2 "Shutdown path of the drive CPU" and Fig. 5-3 "Shutdown path of the NCK-CPU via Terminal 663").

For SI, the shutdown paths are used by the stop functions with the highest priority – STOP A and STOP B. These stop functions can be initiated from each monitoring channel (e.g. if an initiated STOP C, STOP D or STOP E stop function cannot stop the

drives). The perfect functioning of the shutdown paths is therefore absolutely necessary and must be checked at the specified time intervals (e.g. after power-up).

Shutdown path of the drive CPU

The pulse cancellation test can be initiated using the PLC-SGE "test stop selection" (when a fault develops, this can also be internally initiated). The SGE can be supplied from an assigned PLC HW input or a signal (flag) from the PLC user program. The comparator in the drive CPU directly initiates the pulse inhibit via the drive bus in the drive module (internal "cancel pulses" signal). The feedback signal is realized directly from the drive module via the drive bus (internal "status pulses cancelled" signal). Additional wiring is not required. The comparator in the drive channel is supplied via a PLC interface data block (refer to Chapter 4, "Interface signals").

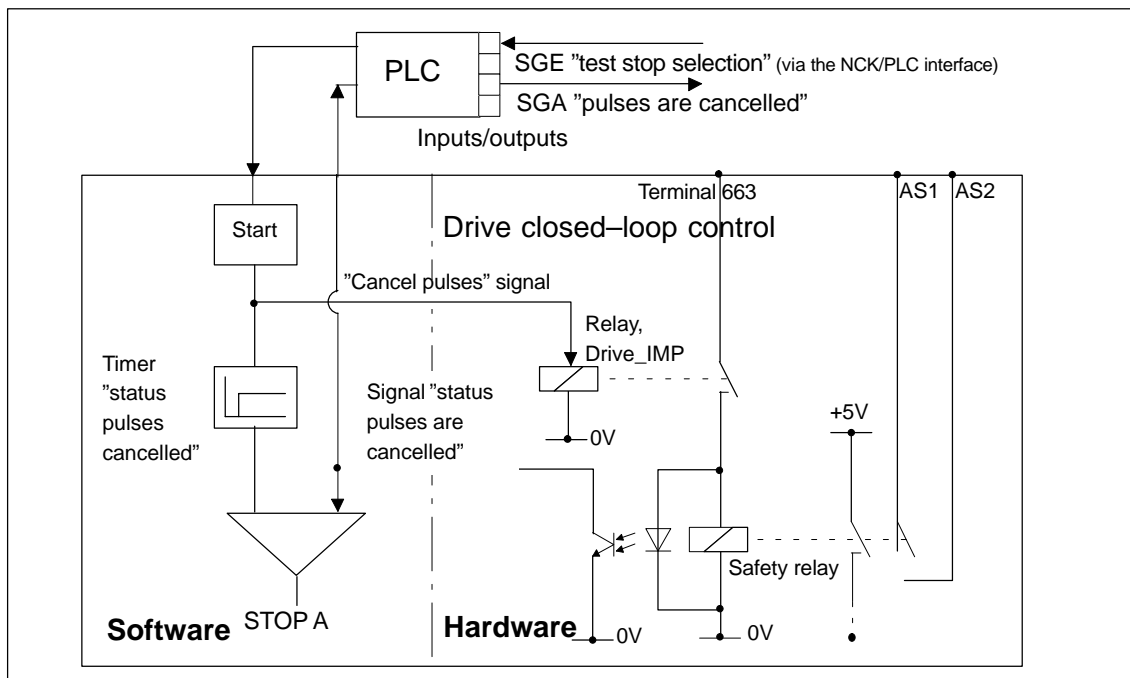

Fig. 5-2 Shutdown paths of the drive CPU

Shutdown path of the NCK-CPU

Two possibilities are available since software release 6.3.30:

1. Via terminal 663
2. Via the internal pulse cancellation

5.1 Basic mechanisms of SI functions

Pulse cancellation via terminal 663

Pulse cancellation is initiated using the NCK-SGE "test stop selection" (this can also be internally initiated when a fault develops). The comparator withdraws the enable signal from the module-specific terminal 663 at the 611digital drive module via the SGA "enable pulses". The status is fed back to the comparator in the NCK-CPU at the SGE "status, pulses cancelled" via the AS1/AS2 terminals of the drive module. The machine data is used to assign the SGEs/SGAs to the NCK hardware inputs/outputs.

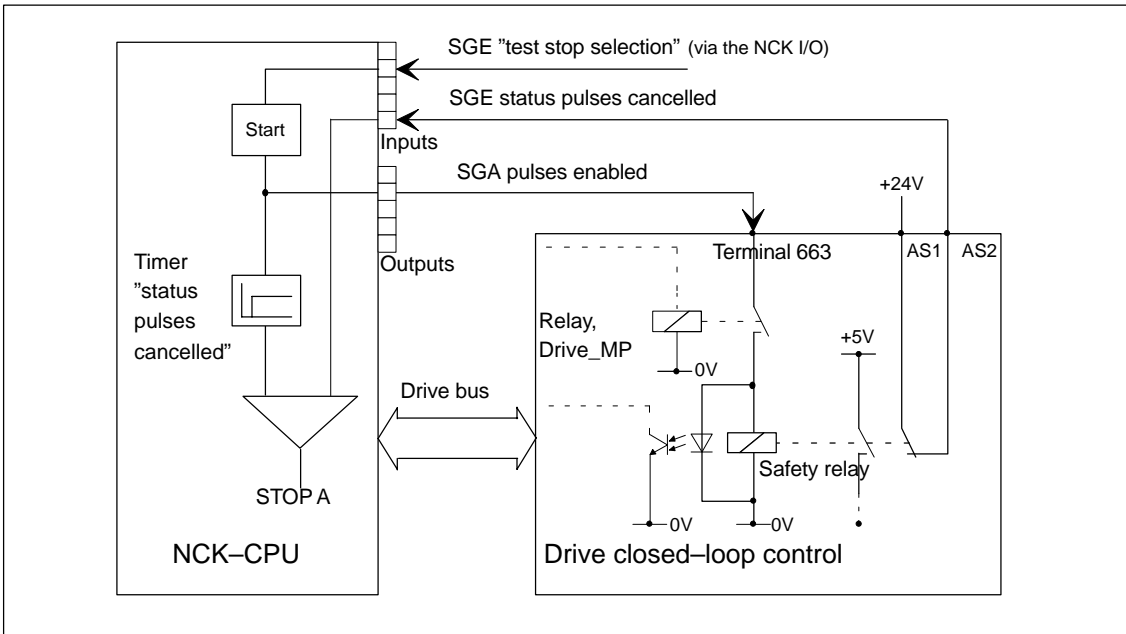

Fig. 5-3 Shutdown path of the NCK-CPU using terminal 663

Note

For the shutdown path of the NCK-CPU, the machinery construction OEM must establish external connections for the axis-specific drive terminal 663 and AS1/AS2.

From NCK software release 6.3. 30, the pulse enable (terminal AS1/AS2) can be fed back internally for all of the control modules.

Safe internal pulse cancellation (from SW 6.3.30)

The internal pulse cancellation can only be used in conjunction with the 611digital High Performance/High Standard modules. In this case, terminal 663 must be connected to the SGA "enable pulses externally". The feedback as to whether the pulses were successfully cancelled can be realized internally. This significantly reduces the number of NCK I/O.

The pulse cancellation sequence is shown in Fig. 5-4. The internal pulse cancellation is initiated using the NCK-SGE "test stop selection" (when a fault conditions exists, this can also be internally initiated as STOP A). The comparator internally cancels the pulses via the drive bus. The status is internally fed back via the drive bus. If the pulses were not successfully cancelled, then the module-specific terminal 663 at the 611digital drive module is withdrawn using the SGA "enable pulses externally". The machine data is used to assign the SGEs/SGAs to the NCK hardware inputs/outputs.

The local NCU inputs/outputs (NC onboard IOs, refer to Chapter 5.10.4) can be used to externally cancel the pulses. Terminals 663 of all or a group of drives are controlled using such an output.

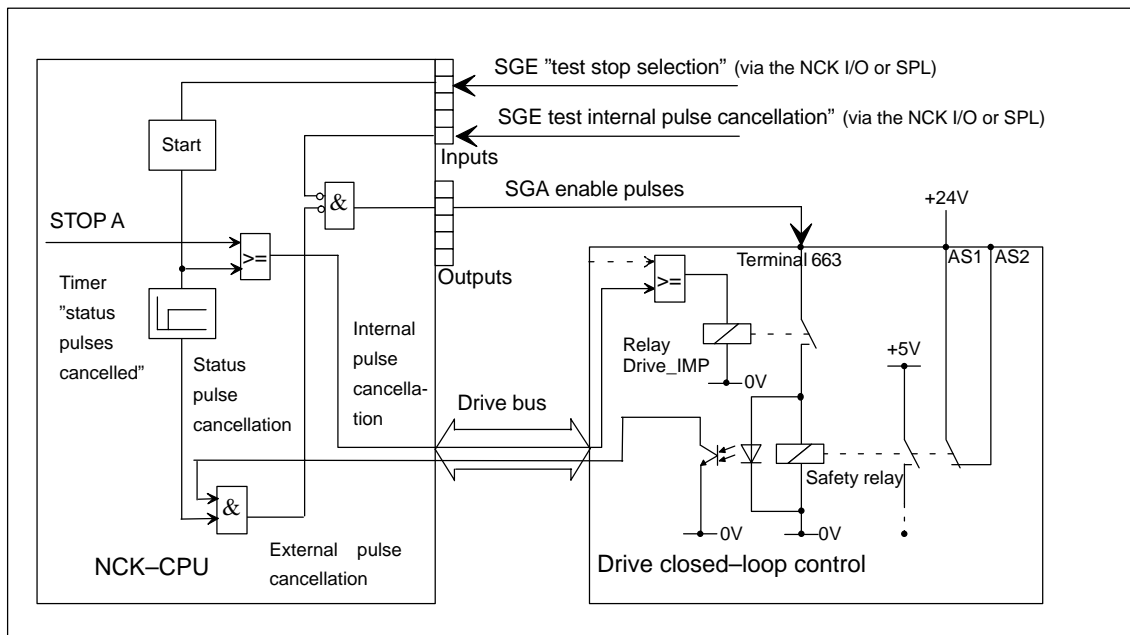

Fig. 5-4 Shutdown path of the NCK-CPU via the internal pulse cancellation

Activating

The function is activated by configuring the SGAs "enable pulses" and "enable pulses externally" as well as the SGEs "test stop, external shutdown".

If bit 30 is set in `$MA_SAFE_PULSE_ENABLE_OUTPUT`, then the pulses are internally cancelled. In this particular case, MD `$MA_SAFE_EXT_PULSE_ENAB_OUTPUT` must be parameterized so that the NCK also has another possibility of canceling the pulses. However, this path is only used if the internal pulse cancellation was to fail.

`$MA_SAFE_PULSE_ENABLE_OUTPUT` can also be configured to a hardware output or to the SPL (refer to Chapter 5.10).

This can be used, for instance, to initiate responses in the SPL when the pulses are cancelled and not when the "pulses are cancelled" status is detected.

5.1.3 Testing the shutdown paths

Description

Using the test stop, for each monitoring channel, the complete shutdown path with external circuitry is tested. When the test is carried-out, the comparators and stop modules of both monitoring channels – responsible for the stop function – are run-through one after the other. Also refer to the Chapter 4.3 "Forced checking procedure".

Instant in time of the test stop

The shutdown paths must be tested (forced checking procedure) at a suitable instant in time. This is generally carried-out after the machine has been powered-up and afterwards in the setting-up mode once within a maximum of 8 hours. We recommend that the test is carried-out before opening protective devices/guards or when the hazardous area is entered (e.g. when selecting the setting-up mode) if the shutdown paths were not tested in the last 8 hours.

Note

The machinery construction OEM should define when the shutdown paths are to be tested in an appropriate "test block".

Prerequisites for the test stop

- All of the drives on the drive module on which the drive to be tested is configured, must be at a standstill.
- At the start, the pulses must still be enabled.
- For vertical (suspended) axes, the manufacturer must ensure that these can be locked (to stop them falling).
- When the test stop is selected, the PLC-SGA "status pulses cancelled" or the NCK-SGE "status pulses cancelled" may not be present, as otherwise stop response STOP F would be initiated.

Which SGEs/SGAs are required for the test stop?

For the test stop, the following SGEs/SGAs are required in each monitoring channel and for each axis/spindle:

- For a test stop in the NCK monitoring channel
NCK-SGE "test stop selection"
NCK-SGE "status pulses cancelled"
NCK-SGA "enable pulses"
- For the test stop in the drive monitoring channel
PLC-SGE "test stop selection"
PLC-SGA "status pulses cancelled"
- For a test stop in the NCK monitoring channel when the pulses are internally cancelled
NCK-SGE "test external pulse cancellation"
NCK-SGA "enable pulses externally"

Message

The "test stop running" message is displayed during the "test stop".

Note

In order that the shutdown paths are correctly tested, the "test stop" must be run twice, separately for the drive and the NC. This ensures that every shutdown channel up to pulse cancellation still functions.

For a 2-axis control module, the shutdown path must be tested on an axis-for-axis basis – i.e. for each axis of the control module.

Test stop sequence

The test stop can either be initiated by hardware using a pushbutton or from the PLC user program using a function block that the user has configured himself (refer to Chapter 10.3.6, "Test stop").

For the **drive monitoring channel, pulse cancellation**

(refer to Fig 5-2 "Shutdown path of the drive CPU") is requested via the PLC-SGE "test stop selection", the "status pulses cancelled" timer is started and the "test stop running" message is displayed on the screen. Pulse cancellation remains active until the timer has expired and the user withdraws the PLC-SGE "test stop selection".

The feedback signal is realized via the PLC-SGA "status pulses cancelled". This feedback signal must be available before the timer, started at the beginning, has expired. If this does not occur, then a "STOP A" is initiated.

The PLC can initiate a test stop in the NCK monitoring channel by appropriately programming the feedback signal of the PLC-SGA "status pulses cancelled" at a PLC output.

5.1 Basic mechanisms of SI functions

Prerequisite:

There is a connection between this PLC output and the NCK-SGE "test stop selection". The pulses must be re-enabled before selecting the test stop in the NCK monitoring channel.

For the **NCK monitoring channel, pulse cancellation is requested using terminal 663**

(refer to Fig 5-3 "Shutdown path of the NCK-CPU") via the NCK-SGE "test stop selection" – the "status pulses cancelled" timer is started, the NCK-SGA "enable pulses" is output and the "test stop running" message is displayed on the screen. The feedback signal is realized using the NCK-SGE "status pulses cancelled" (this is received via terminal AS1/AS2). This feedback signal must be available before the timer, started at the beginning, has expired. If this does not occur, then a "STOP A" is initiated.

For the **NCK monitoring channel, the internal pulse cancellation** is also requested using the NCK-SGE "test stop selection", the NCK-SGA "enable pulses". However, it is not connected to terminal 663 (refer to Fig. 5-4 "Shutdown path of the NCK-CPU using internal pulse cancellation"). However, in addition, the external pulse cancellation via terminal 663 must also be tested.

Testing the external pulse cancellation

The external pulse cancellation is only tested for the NCK through one channel by setting the SGE "test stop external shutdown". The SGE must either be assigned to the NCK I/O or the SPL using the machine data 36979 \$MA_SAFE_STOP_REQUEST_EXT_INPUT. A possible configuration is shown in Fig. 5-5. When the NCK-SPL is being used, the input of single-channel SI-specific signals from the PLC can be used as described in Chapter 3.10.10.

For the external pulse cancellation test it only has to be tested that the wiring of terminal 663 of the configured drive modules is correct. The test stop that utilizes the internal pulse cancellation is also necessary. This was shown as an example in Fig. 5-5 only for the first 2-axis module with axes X and Y.

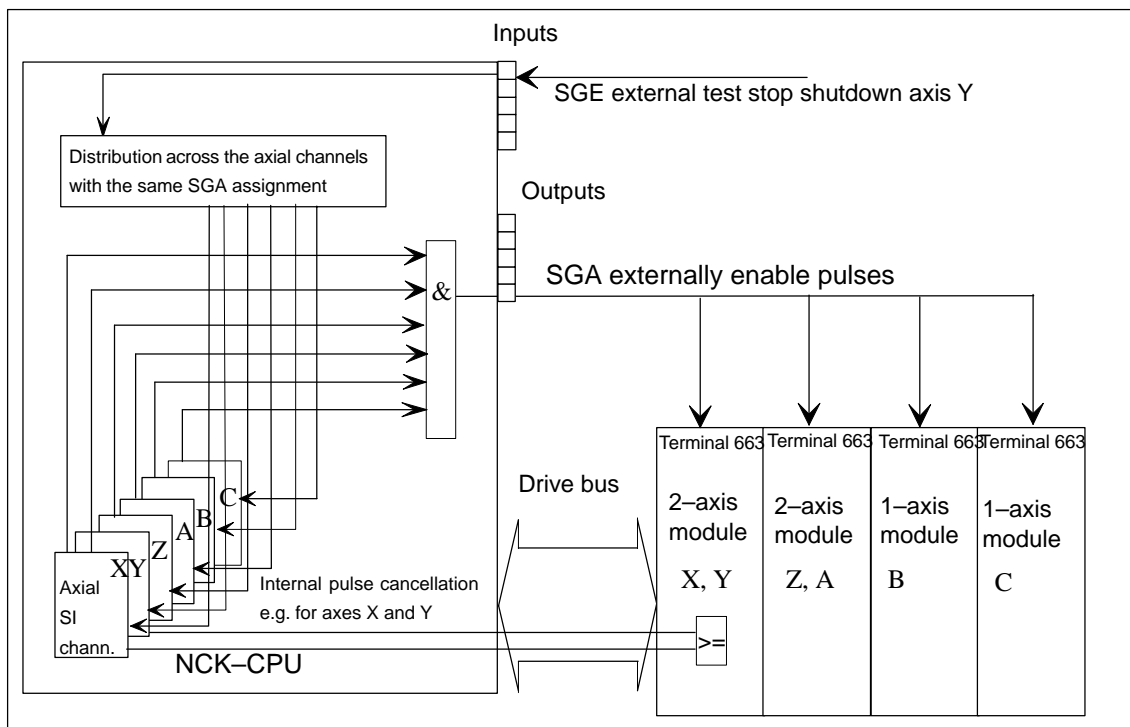

Fig. 5-5 Configuring the "test stop external shutdown"

In order to make it easier for users to configure a test stop and at the same time reduce the time required for a test stop, the external pulse cancellation test is only initiated for one axis for each configured peripheral output. As an example, axis Y is used in Fig. 5-5. Pulse cancellation is checked for all axes whose SGA is assigned to this output (`$MA_SAFE_EXT_PULSE_ENAB_OUTPUT`); this means for all 6 axes X, Y, Z, A, B, C in Fig. 5-5.

Alarm 27006, "Axis %1 test ext. pulse cancellation running" is displayed while testing the external pulse cancellation for all of these axes.

Note

During "test stop external shutdown", no external stop may be present at the drive. If this is not the case, and if the test stop is present for longer than `$MA_MODE_SWITCH_TIME`, this results in Alarm 27001, "Fault in a monitoring channel" with Information 58, active external stop request.

Sequence:

The sequence of the "test stop external shutdown" is comparable with the sequence for the test stop of the NCK monitoring channel.

After selecting "test stop external shutdown", the SGA "enable pulses externally" is deleted (cleared) and a timer with the value from MD `$MA_SAFE_PULSE_DIS_CHECK_TIME` is started. If the timer has expired without feedback that the pulses have been cancelled, then Alarm 27001 is output with

5.1 Basic mechanisms of SI functions

code number 1010. By initiating a STOP A for the drive, the pulses are cancelled via the internal shutdown path. This state can only be exited with a power on.

The state of the active monitoring functions (SBH, SG, SE, SN) is not changed by the "test stop external shutdown".

Feedback signals, pulse cancellation (from SW 6.3.21)

The SGE "status pulses cancelled" is only used to check the pulse cancellation for a test stop or the "test stop external shutdown". This is the reason that this signal can be configured according to the 3-terminal principle through one channel. This means that this information no longer has to be provided for all 611 digital modules by connecting terminals AS1/AS2 to the NCK I/O. Here, the 3-terminal principle is used to control pulse cancellation through two channels with the feedback signal through one channel.

Activating

The function is activated by configuring the SGE "status pulses cancelled". Up until now, the assignment to an input or to the NCK-SPL had to be made via MD \$MA_SAFE_PULSE_STATUS_INPUT. If this machine data is now set to 0, the information as to whether or not the pulses have been cancelled is retrieved from the SI interface of the 611 digital.

Testing the shutdown paths for several axes without SPL

The test stop is executed internally in the drive monitoring channel (via the NC/PLC interface). In order to implement the test stop for the NCK monitoring channel, the SGEs/SGAs must be appropriately connected-up for each axis.

For several axes, a large number of inputs and outputs are required in the NCK. It is possible to group or distribute signals using inputs/outputs assigned using the appropriate machine data (refer to Chapter 4, "Data Description").

To obtain the "test stop selection" signal of a certain axis, it must be possible to specifically evaluate the feedback signal "pulses cancelled status" for the same axis in order to detect if there are any faults/errors.

Testing the shutdown paths for a dual-axis module

For a dual-axis module, there is only one terminal 663 and one AS1/AS2 for both axes. The shutdown path in the NCK and drive monitoring channels must still be tested in succession for both axes.

5.1 Basic mechanisms of SI functions

The following example (refer to Fig. 5-6, "Testing the shutdown path") shows a circuit to test the shutdown path of the NCK with four axes. Axes 3 and 4 are implemented in the form of a dual-axis module.

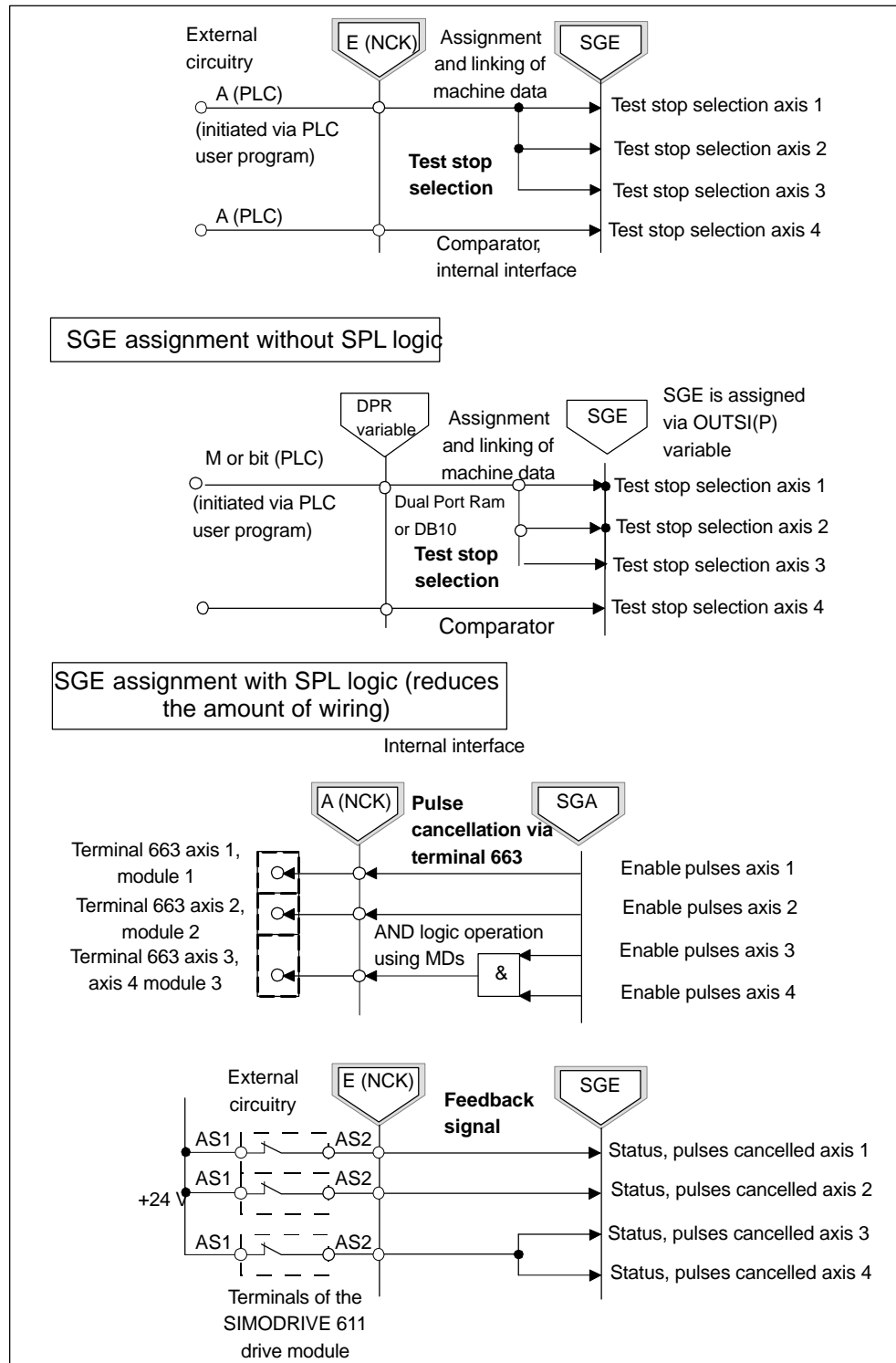

Fig. 5-6 Testing the shutdown paths (NCK monitoring channel) for several axes

5.1 Basic mechanisms of SI functions

To test the shutdown path in the drive monitoring channel, it is possible to access the input and output signals of all of the axes from the PLC program via the PLC interface.

5.1.4 Overview of the machine data for the shutdown paths

Overview of MD for 840D

Table 5-1 Overview of machine data for 840D

Number	Identifier
36950	\$MA_SAFE_MODE_SWITCH_TIME
36957	\$MA_SAFE_PULSE_DIS_CHECK_TIME
36975	\$MA_SAFE_STOP_REQUEST_INPUT
36976	\$MA_SAFE_PULSE_STATUS_INPUT
36979	\$MA_SAFE_STOP_REQUEST_EXT_INPUT
36984	\$MA_SAFE_EXT_PULSE_ENAB_OUTPUT
36986	\$MA_SAFE_PULSE_ENABLE_OUTPUT
Note: Data is described in Chapter 6.1, "Machine data for SINUMERIK 840D"	

Overview of MD for 611digital

Table 5-2 Overview of machine data for 611digital

Number	Identifier
1357	\$MD_SAFE_PULSE_DIS_CHECK_TIME
Note: Data is described in Chapter 6.2, "Machine data for SIMODRIVE 611digital"	

Note

The inputs and outputs of the SGEs/SGAs are assigned to the drive channel using data blocks in the PLC user program (refer to Chapter 6.4, "Interface signals").

5.1.5 Stop responses

A high degree of security against faults/errors is afforded by the two-channel system structure with its permanent, crosswise data comparison. Alarms and stop responses are initiated when differences are detected between the two channels. The purpose of the stop responses is to safely stop the drives in a controlled fashion according to the actual machine requirements. A differentiation is made between the stop responses STOP A, B, C, D, E, F and the test stop. The type of stop response that occurs in the event of a fault/error can either be pre-determined by the system or configured by the machinery construction OEM.

Note

Protection of personnel must be given top priority when stop responses are configured. The objective is to stop the drives in a way that best suits the situation.

Table 5-3 Overview of stop responses

STOP	Action	Effect	Initiated in response to	Changes to	Alarm
A	Pulses are immediately cancelled	Drive coasts down	SBR/SG	SH	POWER ON
B	0 speed setpoint is immediately entered + timer t_B started $t_B = 0$ or $n_{act} < n_{shutdown}$: STOP A	Drive is braked along the current limit – transition to STOP A	SBH/SG	SH	POWER ON
C	0 speed setpoint is immediately entered + timer t_C started $t_C = 0$: SBH is activated	Drive is braked along the current limit SBH active	SG/SE	SBH	RESET
D	Motor is braked along the acceleration + timer t_D started $t_D = 0$: SBH is activated	Drive is braked as part of a group along the path SBH active	SG/SE	SBH	RESET
E	Results in stopping and retraction + timer t_E started $t_E = 0$: SBH is activated	Drive is braked along the programmed retraction and stopping motion (ESR). SBH active	SG/SE	SBH	RESET

5.1 Basic mechanisms of SI functions

Table 5-3 Overview of stop responses

STOP	Action	Effect	Initiated in response to	Changes to	Alarm
F	Depending on the particular situation a) Safety function inactive: Saved (latched) message to the operator b) Safety function active: STOP B/A is initiated (can be configured) c) Safety function active and STOP C, D or E initiated: Saved (latched) message to the operator	a) NC start and traversing interlock b) Transition to STOP B/A c) NC start and traversing interlock	Crosswise data comparison	SH	a) RESET b) POWER ON c) RESET
<p>Note: The timers can be set using the appropriate machine data.</p>					

Stop responses SBH and SH

Fig. 5-7 shows the relationship between the stop responses and the safe operating stop (SBH) or the safe standstill (SH).

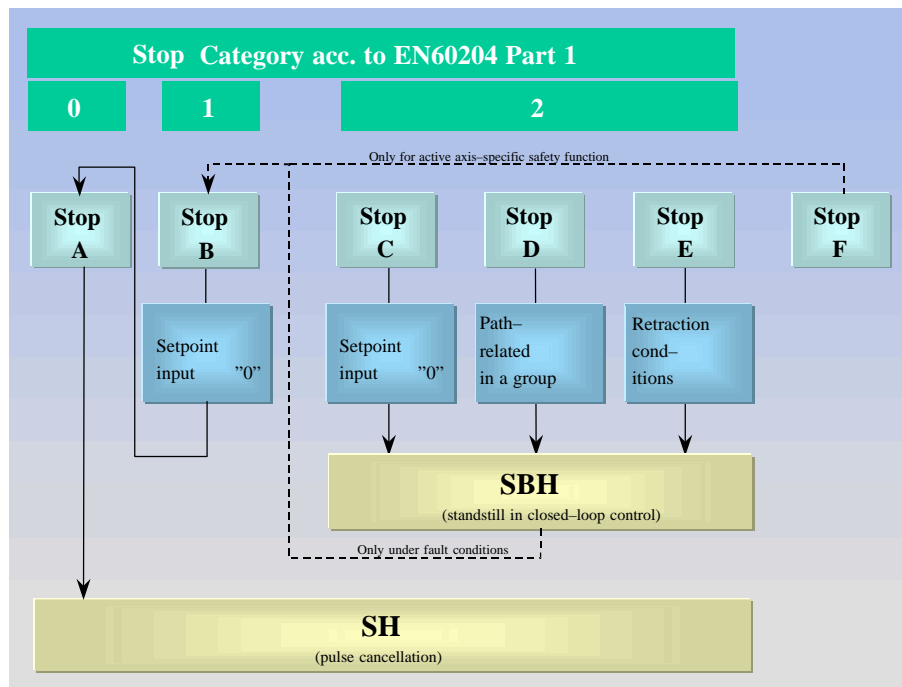

Fig. 5-7 Stop responses, safe operating stop (SBH), safe standstill (SH)

Configurable stop responses

The stop responses that occur when limit values are violated can be selected by the machinery construction OEM using the appropriate machine data. These limit values are defined using the corresponding machine data:

Table 5-4 Configurable stop responses

Safety-related function	Configurable stop responses
SBH	STOP B* (cannot be configured)
SG	STOP A, B, C, D, E
SE	STOP C, D, E
SN	No internal stop response The user must appropriately configure safe responses using the SGAs SN1 – SN4.
SBR	STOP A (cannot be configured)
Note: If discrepancies are detected in the crosswise data comparison, the STOP F stop response is permanently set. * There is an immediate transition from STOP B to A if $t_B = 0$	

Assignment table for stop responses

Table 5-5 Stop responses for SI acc. to EN 60204-1

Stop response for SINUMERIK Safety Integrated®	Stop function acc. to EN 60204-1
STOP A	Category 0
STOP B, STOP F 1)	Category 1
STOP C, STOP D, STOP E	Category 2
Note: 1): STOP F triggers STOP B if at least one safety-related function is active.	

Priority of the stop responses

Table 5-6 Priority for the stop responses

Priority level	Stop response
Highest priority	STOP A
.....	STOP B
.....	SGE test stop selection
.....	STOP C

5.1 Basic mechanisms of SI functions

Table 5-6 Priority for the stop responses

Priority level	Stop response
...	STOP D
.	STOP E
Lowest priority	STOP F

Note

A stop response listed in Table 5-6 "Priorities for stop responses" can only be initiated if at least one safety-related function is active (except for STOP F).

Once a stop response has occurred, the sequence of operations it involves will be completed even if the cause of the stop no longer exists.

It is possible to advance to stop responses that have a higher priority. It is not possible to advance to stop responses that have a lower priority.

The function of the SGE test stop selection is described in Chapter 5.1.2.

Stop response sequence

If a stop response is initiated in the drive, a signal is sent to the NC that responds by initiating the same stop response (two-channel safety). Likewise, if a stop response is initiated in the NC, the drive is automatically signaled and responds by requesting the same stop response (exception: Test stop).

This mechanism ensures that stop responses are managed with a high degree of safety.

Description of STOP A

Action in the drive monitoring channel:

Pulses are immediately cancelled using the internal signal "cancel pulses". In addition, the pulses in the gating unit are cancelled by a software function.

Action in the NCK monitoring channel:

Pulses are cancelled via the SGA "enable pulses"

- Effect:
The drive coasts to a standstill if no external braking mechanism such as an armature short-circuit and/or holding brake is used. The axis-specific alarm results in a mode group stop, i.e. as the result of the error in one axis, all axes and spindles in a mode group are stopped. Safe standstill becomes effective at the end of STOP A.
- Alarm message:
The alarm message "STOP A triggered" is displayed.

- **Acknowledgment:**
An unintentional restart is prevented for STOP A. The error can only be acknowledged from the drive and control using a power on.

SGA STOP A/B active

This signal indicates that STOP A/B is active.

0 signal: STOP A/B is not active.

1 signal: STOP A/B is active.



Warning

If the "safe standstill" function or "STOP A" is activated, the motor can no longer generate any torque. This is the reason that potentially hazardous motion can occur, e.g. for the following:

- When an external force acts on the drive axes
- Vertical and inclined axes without weight equalization
- Axes that are moving (coasting down)
- Direct drives with low friction and low self-locking
- Notching torques (depending on the motor type, bearing design and friction characteristics, up to half a pole pitch in a direction that cannot be predicted).

Possible hazards must be clearly identified using a risk analysis that must be carried-out by the manufacturer. With an assessment, based on this risk analysis, it should be defined as to which additional measures are required, e.g. external brakes.

Description of STOP B

Action in the drive and NCK monitoring channel:

The drive is braked at the current limit as the result of a 0 speed setpoint that is input instantaneously either directly or from the NCK via the drive bus.

Action in the drive monitoring channel:

If the speed actual value drops below the value set in \$MD_SAFE_STANDSTILL_VELO_TOL or if the timer set in \$MD_SAFE_PULSE_DISABLE_DELAY has expired, the stop mode changes automatically to STOP A.

Action in the NCK monitoring channel:

Essentially the same as in the drive channel, the stop mode changes automatically to STOP A when the actual speed drops below the value in \$MA_SAFE_STANDSTILL_VELO_TOL or after the timer set in \$MA_SAFE_PULSE_DISABLE_DELAY has expired.

- **Effect:**
The drive is braked along the current limit under closed-loop speed control and brought to a safe standstill.
- **Alarm message:**
The alarm message "STOP B triggered" is displayed.
- **Acknowledgment:**
An unintentional restart is prevented for STOP B. The error can only be acknowledged from the drive and control using a power on.

5.1 Basic mechanisms of SI functions

SGA STOP A/B is active

This signal indicates that STOP A/B is active.

0 signal: STOP A/B is not active.

1 signal: STOP A/B is active.

Note

If the timer in machine data \$MA_SAFE_PULSE_DISABLE_DELAY is set to zero, then there is an immediate transition from STOP B to STOP A.

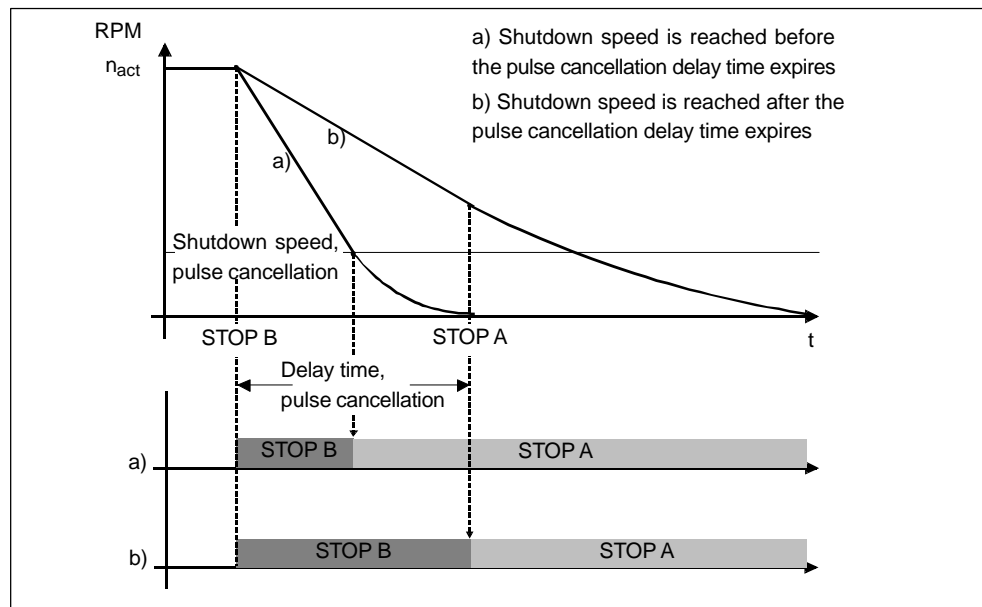

Fig. 5-8 Transition from STOP B to STOP A

Description of STOP C

Action in the drive monitoring channel:

The drive is braked at the current limit in response to a zero speed setpoint. The timer set in \$MD_SAFE_STOP_SWITCH_TIME_C is simultaneously started. The SBH function is automatically activated after the timer expires.

Action in the NCK monitoring channel:

Essentially the same as in the drive, the control specifies a zero speed setpoint and the interface signal "position controller active" (DB 31, ... DBX 61.5) of the associated drive is set to zero.

At the same time, the timer set in \$MA_SAFE_STOP_SWITCH_TIME_C is started. The SBH function is automatically activated after the timer expires.

- Effect:

The drive is braked at the current limit under closed-loop speed control and brought into SBH.

- Alarm message:
The alarm message "STOP C triggered" is output (refer to Chapter 8, "Alarms").
- Acknowledgment:
An unintentional restart is prevented for STOP C. The error can be acknowledged using the NC-RESET key.

SGA STOP C is active

This signal indicates that STOP C is active.

0 signal: STOP C is not active.

1 signal: STOP C is active.

Description of STOP D

Action in the drive monitoring channel:

The drive monitoring channel requests a path stop or braking along the acceleration characteristic (NC-MD). At the same time, the timer set in \$MD_SAFE_STOP_SWITCH_TIME_D is started. The SBH function is automatically activated after the timer expires.

Action in the NCK monitoring channel:

Essentially the same as the drive, the control system monitoring channel requests a path stop or braking along the acceleration characteristic (NC-MD). At the same time, the timer set in \$MA_SAFE_STOP_SWITCH_TIME_D is started. The SBH function is automatically activated after the timer expires.

- Effect:
The drive is braked in a group – including simultaneous axes – along the set traversing path. Endlessly rotating axes are braked at the acceleration limit. The SBH function is automatically activated after the timer expires.
- Alarm message:
The alarm message "STOP D triggered" is output.
- Acknowledgment:
An unintentional restart is prevented for STOP D. The error can be acknowledged using the NC-RESET key.

SGA STOP D is active

This signal indicates that STOP D is active.

0 signal: STOP D is not active.

1 signal: STOP D is active.

Description of STOP E (from SW 6.4.15)

Action in the drive monitoring channel:

The drive monitoring channel requests an extended stop and retract (ESR). At the same time, the timer set in \$MD_SAFE_STOP_SWITCH_TIME_E is started. The SBH function is automatically activated after the timer expires.

Action in the NCK monitoring channel:

Essentially the same as the drive, ESR is requested by the control monitoring channel. At the same time, the timer set in \$MA_SAFE_STOP_SWITCH_TIME_E is started. The SBH function is automatically activated after the timer expires.

5.1 Basic mechanisms of SI functions

- Effect:
The extended stop and retract that have been configured are started.
- Alarm message:
The alarm message "STOP E triggered" is displayed.
- Acknowledgment:
An unintentional restart is prevented for STOP E. The error can be acknowledged using the NC-RESET key.

SGA STOP E is active

This signal indicates that STOP E is active.

0 signal: STOP E is not active.

1 signal: STOP E is active.

The NC-controlled ESR is triggered by writing to the system variable \$AC_ESR_TRIGGER=1 (also refer to /FB3/, M3 "Axis coupling and ESR"). To obtain the criteria for triggering, the following SI system variables have been introduced:

\$VA_STOPSI:

Axial system variable that contains the present stop.

For a value of 4, a Stop E is active for this axis.

\$A_STOPESI:

Global system variable that displays a value not equal to 0 to indicate that a Stop E is active on one of the axes. This variable saves the user having to search through all of the axes.

Note

STOP E only produces a different response than STOP D if the user has configured the ESR function – extended stop and retract – and initiation of the ESR is programmed depending on \$VA_STOPSI or \$A_STOPESI.

If ESR is not active, the STOP E behaves like a STOP D. However, if the ESR configuration is incorrect, there is a delay of up to 2 IPO cycles compared to STOP D until the braking operation is initiated. Possible causes:

- The initiation of the ESR as static synchronous action does not take into account the system variables \$VA_STOPSI or \$A_STOPESI.
- ESR is neither parameterized nor enabled.
- For individual PLC controlled axes, only the axis-specific ESR is used via \$AA_ESR_TRIGGER. This trigger may be used in addition to the channel-specific trigger.

For other incorrect ESR programming, a delay by the time entered in \$MC_ESR_DELAY_TIME1 and \$MC_ESR_DELAY_TIME2 is possible. After these times have expired, braking is initiated at the current limit. Possible cause:

- The retraction position cannot be reached within the specified time.

Description of STOP F

The STOP F response is permanently assigned to the crosswise data comparison. Dormant faults/errors are detected in the drive and control systems.

- Effect:
When a discrepancy is detected between the drive and NCK monitoring channel, the following responses are initiated:

Response, if no safety functions are active:

Dormant faults/errors are also detected if none of the safety-related functions are active (safety functions are SBH, SG, SE, SN). The saved message "defect in a monitoring channel" is output on both the drive and control sides and can only be acknowledged using the NC-RESET key. The message does not interrupt machining. A system restart is prevented by an internal NC start/traversing inhibit function.

Response if one safety function is active:

Dormant faults/errors are detected. A STOP B/A response is initiated in the drive and control system (refer to description of STOP B).

Exception: If a STOP C/D/E is already active (refer to Table 5-4 "Configurable stop responses").

A delay time before STOP B is initiated can be parameterized using MD 36955 \$MA_SAFE_STOP_SWITCH_TIME_F. During this time, the machinery construction OEM can initiate an NC controlled response, e.g. ESR. After this time has expired, the involved axis is braked with STOP B. This is also true if, in the meantime, a stop with a higher priority than STOP F (STOP E, D, C) is present. The

5.1 Basic mechanisms of SI functions

system variables \$VA_XFAULTSI and \$A_XFAULTSI, bit 1 can be used to detect whether a STOP F was initiated that is then followed by a STOP B. In the delay time up to the STOP B, an ESR or braking along the programmed path can be initiated (e.g. by writing to \$AC_ESR_TRIGGER or initiating an external STOP D).

Note

A delay time between STOP F and STOP B should only be set, if, during this time, an alternative response is initiated by evaluating the system variables \$VA_XFAULTSI and \$A_XFAULTSI.

Further, when using the delay time, a monitoring function should always be active – also in the automatic mode (e.g. SE, SN, SG with high limit switch). If, for example, the SBH monitoring function is only active on the drive side as a result of the (single-channel) failure of a door switch then this results in a STOP F. However, this does not result in a STOP B on the NCK side, if, beforehand, no monitoring function was active. This means that the drive, in this case, responds with a STOP B and this is not displayed in the NCK variables \$VA_XFAULTSI and \$A_XFAULTSI.

The appropriate monitoring functions of the drive (e.g. when SBH is selected) are also executed instantaneously without any delay.

- Alarm message:
The alarm "Defect in a monitoring channel" is displayed. An entry to provide details on the error is made in the following machine data.

Table 5-7 Machine data for detailed fault code, STOP F

MD number	Control	Meaning
–	840D	For 840D, the fault code is displayed when the alarm is output.
1395	611digital	\$MD_SAFE_STOP_F_DIAGNOSIS
Note: The significance of the fault codes can be found in Chapter 6, "Alarms for SINUMERIK 840D" under Alarm 27001 "Defect in a monitoring channel."		

- Acknowledgment:
The saved alarm can be acknowledged using the NC-RESET key. For STOP B/A, an unintentional restart is prevented. The error can only be acknowledged from the drive and control using a power on.

Example 1 – delaying the transition from STOP F to STOP B:

The speed characteristics of an axis for parameterized stopping are shown in Fig. 5-9. In this case, the axis should continue 500 ms and then brake along the parameterized ramp. A delay time of 2.5 s is selected until STOP B is initiated (\$MA_SAFE_STOP_SWITCH_TIME_F).

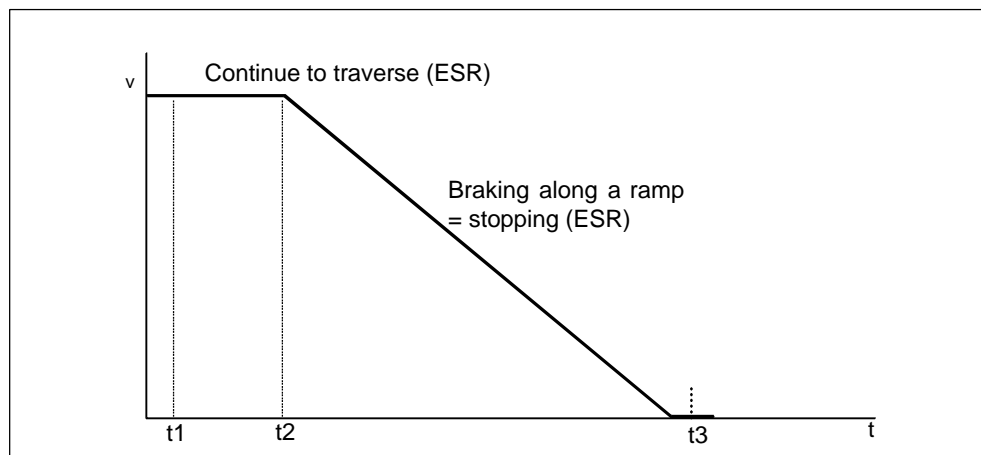

Fig. 5-9 Velocity characteristic of an SI axis when stopping with STOP F

The following actions take place at the following instants in time:

t1:

STOP F occurs, ESR is started

t2:

500 ms after t1, braking starts along the parameterized ramp

t3:

STOP B is initiated 2.5 s after t1. The axis is already stationary at this time, which means that the pulses can be immediately cancelled.

Example 2 – delaying the transition from STOP F to STOP B

The same parameterization as in Example 1 is shown in Fig. 5-10. However, when a STOP F occurs, no monitoring function is active. At instant in time t2, a monitoring function is activated. ESR is only started if there is a STOP F with active monitoring function.

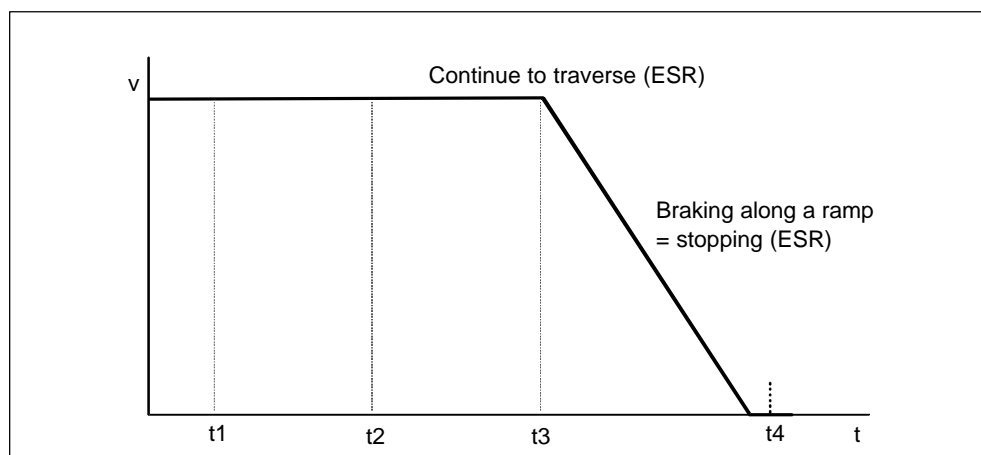

Fig. 5-10 Velocity characteristic of an SI axis when stopping with STOP F

5.1 Basic mechanisms of SI functions

The following actions take place at the following instants in time:

t1:

STOP F occurs, no response

t2:

At any time after t1, a monitoring function is activated. At this instant in time, the transition to a STOP B is started and bits 1 in \$A_XFAULTSI and \$VA_XFAULTSI of this axis are set.

t3:

500 ms after t2, braking starts along the parameterized ramp

t4:

STOP B is initiated 2.5 s after t2. The axis is already stationary at this time, which means that the pulses can be immediately cancelled.

5.1.6 Overview of the machine data for a stop response

Overview of MD for 840D

Table 5-8 Overview of machine data for 840D

Number	Identifier
36952	\$MA_SAFE_STOP_SWITCH_TIME_C
36953	\$MA_SAFE_STOP_SWITCH_TIME_D
36954	\$MA_SAFE_STOP_SWITCH_TIME_E
36955	\$MA_SAFE_STOP_SWITCH_TIME_F
36956	\$MA_SAFE_PULSE_DISABLE_DELAY
36957	\$MA_SAFE_PULSE_DIS_CHECK_TIME
36960	\$MA_SAFE_STANDSTILL_VELO_TOL
36961	\$MA_SAFE_VELO_STOP_MODE
36962	\$MA_SAFE_POS_STOP_MODE
36963	\$MA_SAFE_VELO_STOP_REACTION
Note: Data is described in Chapter 6.1, "Machine data for SINUMERIK 840D"	

Overview of MD for 611digital

Table 5-9 Overview of machine data for 611digital

Number	Identifier
1352	\$MD_SAFE_STOP_SWITCH_TIME_C
1353	\$MD_SAFE_STOP_SWITCH_TIME_D
1354	\$MD_SAFE_STOP_SWITCH_TIME_E
1355	\$MD_SAFE_STOP_SWITCH_TIME_F
1356	\$MD_SAFE_PULSE_DISABLE_DELAY
1357	\$MA_SAFE_PULSE_DIS_CHECK_TIME
1360	\$MD_SAFE_STANDSTILL_VELO_TOL
1361	\$MD_SAFE_VELO_STOP_MODE
1362	\$MD_SAFE_POS_STOP_MODE
1363	\$MA_SAFE_VELO_STOP_REACTION
1395	\$MD_SAFE_STOP_F_DIAGNOSIS
Note: Data is described in Chapter 6.2, "Machine data for SIMODRIVE 611digital"	

5.2 External STOPS

Description

Using this function, it is possible to bring the drive to a standstill using the SGEs. Sensors (e.g. protective mats, light barriers, ...) can be connected to the SGEs. Stopping the drives is then initiated depending on these connected sensors. The drives can be brought to a standstill in the following ways:

- By canceling the drive pulses SGE "de-select ext. STOP A"
- Braking with $n_{\text{set}} = 0$ SGE "de-select ext. STOP C"
- Braking along a path SGE "de-select ext. STOP D"
- Initiating ESR SGE "de-select ext. STOP E" (from SW 6.4.15)

Note

External STOPS only function in conjunction with "safe programmable logic" (SPL). The reason for this is that an external STOP A remains selected – for safety reasons, until SPL crosswise data comparison of the PLC and NCK is started.

Enabling and activating the function

The function "external STOPS" is enabled and activated using the following machine data:

- Enabling the function
MD 36901/1301: \$MA_/\$MD_SAFE_FUNCTION_ENABLE
(enables safety-related functions)
Bit 0: Enable SBH/SG (refer to the note)
Bit 6: Enable external STOPS
Bit 4: Enable external STOP E

Note

- In addition to enabling the function "external STOPS", function SBH/SG must also be enabled as a minimum requirement.
 - The external STOP E must be enabled with bit 4 = 1 in addition to bit 6 "enable external STOPS".
-

Assignment to an input terminal and/or system variable

In order to trigger a stop via the NCK monitoring channel, an input terminal or a system variable must be assigned to the stop request.

Assigning to the input terminals

This assignment is configured using the following machine data:

MD 36977: \$MA_SAFE_EXT_STOP_INPUT[n]:

(input assignment, external stop request) with n = 0, 1, 2, 3.

Note

- For stopping types that are **not used**, the assignment must be inverted by appropriately parameterizing MD 36977[n]. This means that they are set to a "1" signal and are permanently "inactive".

Exception:

- STOP E is interlocked by its own enable signal.
-

An external Stop E can also be initiated as an error response to a crosswise data comparison of NCK and PLC-SPL or for PROFIsafe errors, instead of a STOP D.

Parameterization on the NCK side is carried-out using MD10097:

\$MN_SAFE_SPL_STOP_MODE = 4 – on the PLC side using DB 18, DBX36.1=1.

This parameterization is checked in the crosswise data comparison between PLC-SPL and NCK-SPL (refer to Chapter 5.10 "Safe programmable logic").

If the value 4 is parameterized in MD10097, without enabling the external Stop E in all axes with SI function enable, then Alarm 27033 is output for all of these axes.

5.2 External STOPS

SGEs to stop the drive

The following SGEs are available to stop the drive:

Table 5-10 SGEs to stop the drive

SGE	Stopping type	Priority
De-select ext STOP A (= SH de-selection)	Pulse cancellation	High
De-select ext. STOP C	Braking with $n_{set} = 0$...
De-select ext. STOP D	Braking along a path	...
De-select ext. STOP E	ESR is initiated	Low

Notes:
 SGE "..." = 1 Stopping is not triggered (it is de-selected)
 SGE "..." = 0 Stopping is triggered (it is selected)
 If a stop request is selected simultaneously using several SGEs, then that with the highest priority is executed.
 If one of the SGEs changes, the "tolerance time for SGE changeover" is activated (MD 36950/1350).
 Feedback signals:
 for SGE "de-select ext. STOP A": via SGA "status pulses cancelled" and SGA "STOP A active"
 for SGE "de-select ext. STOP C": via SGA "STOP C active"
 and SGE "de-select ext. STOP D": via SGA "STOP D active"
 and SGE "de-select ext. STOP E": via SGA "STOP E active"

Differences between stopping via an internal STOP A, C, D and external STOP A, C, D via SGEs

The internal stop responses STOP A (pulse cancellation), STOP C (braking with $n_{set} = 0$) and STOP D (braking along a path) triggered by the safety monitoring functions, brake the drive accordingly and in addition output an alarm that must be acknowledged with POWER ON or RESET.

On the other hand, when initiating the external stops, only STOP A or the braking of the drive is triggered (STOP C or STOP D) and monitored through two channels. Additional responses are only triggered if one of the monitoring functions still active is violated.

Note

- For external STOPS, alarms are not displayed. This means that the user himself must configure the required message/signal.

Acknowledging a stop request

After requesting a specific stop type via SGE, this sequence can be cancelled by one of the following events:

- De-selecting the stop request
- Selecting a stop request using an SGE with a higher priority
- A higher stop request (STOP A; B; C or D) with a higher priority is received from an internal monitoring function

Effects of the stop responses on other axes/spindles

If a stop response is triggered, then this has the following effects on all of the other axes in the same channel:

STOP E: Extended stopping and retraction is initiated

STOP D: Braking along a path

STOP C: IPO fast stop (braking at the current limit)

STOP A: IPO fast stop (braking at the current limit)

The effect on the other axes in the channel can be influenced using the MD `$MA_SAFE_IPO_STOP_GROUP`. This allows, for example, the pulses of a spindle to be safely cancelled (using an external STOP A), in order that this spindle can be manually turned and the axes can still be moved while being safely monitored.

STOP	<code>\$MA_SAFE_IPO_STOP_GROUP = 0</code>	<code>\$MA_SAFE_IPO_STOP_GROUP = 1</code>
C before SW 6.3.21	All axes of the channel decelerate at the current limit.	Axes that interpolate with the involved axis brake at the current limit. All other axes are not braked.
C from SW 6.3.21	Axes that interpolate with the involved axis brake at the current limit. All other axes brake along the parameterized braking ramp.	Axes that interpolate with the involved axis brake at the current limit. All other axes do not brake.
D	Axes/spindles brake along the path or along the parameterized braking ramp.	Axes that interpolate with the involved axis brake along the parameterized braking ramp. All other axes do not brake.
E	<u>ESR enabled and active:</u> ESR is initiated <u>ESR neither active nor enabled:</u> After a delay time of max. 2 lpo clock cycles, the behavior as described for STOP D is initiated.	

5.2.1 Test stop for external STOPS

The introduction of another method for activating STOP A, C, D and E via SGEs means that it is also necessary that this branch is subject to a forced checking procedure.

The test stop of external STOPS is divided into the following 2 phases:

- Phase 1
 - The shutdown path is tested as usual (refer to Chapter 5.1.3, "Testing shutdown paths"). This tests the correct functioning of the safe pulse cancellation. Successful completion of this phase is signaled as follows
 - For the NCK monitoring channel:
A positive feedback signal is returned in the form of a 0/1 edge from the SGE "status, pulses cancelled".
 - For the drive monitoring channel:
The positive feedback is indicated by the SGA "status pulses cancelled".
- Phase 2
 - After safe pulse cancellation has been checked for both channels in phase 1, for phase 2, it is sufficient to test the functionality of the SGE stop request.
 - Procedure:
All externally wired/used stop SGEs are switched one after the other in each channel and the positive response evaluated using the associated SGA "STOP x is active".

Note

Phase 2 only has to be performed if the function "external STOPS" is enabled (using MD 36901/1301).

Only the enabled and activated external standstill functions have to be tested.

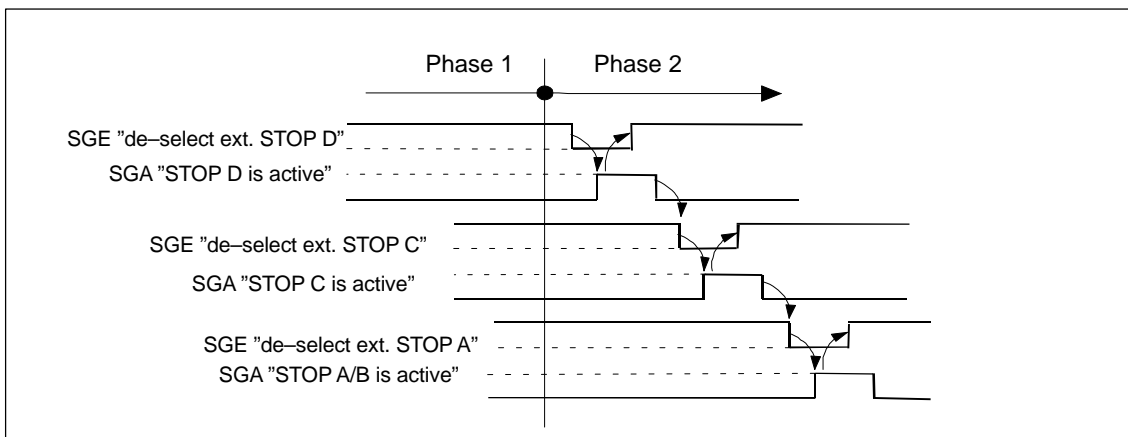

Fig. 5-11 Sequence of the test stop for external STOPS. Example: All external STOPS (SGEs) are used

Which SGEs/SGAs are required for the test stop of external STOPS?

The following SGEs/SGAs can be used to perform the test stop for external STOPS:

Table 5-11 SGEs/SGAs for the test stop, external STOPS

	Phase 1	Phase 2
NCK monitoring channel	NCK-SGE "test stop selection" NCK-SGE "status pulses cancelled" NCK-SGA "enable pulses"	NCK-SGE "de-select ext. STOP A" NCK-SGA "STOP A/B is active" NCK-SGE "de-select ext. STOP C" NCK-SGA "STOP C is active" NCK-SGE "de-select ext. STOP D" NCK-SGA "STOP D is active" NCK-SGE "de-select ext. STOP E" NCK-SGA "STOP E is active"
Drive monitoring channel	PLC-SGE "test stop selection" PLC-SGA "status pulses cancelled"	PLC-SGE "de-select ext. STOP A" PLC-SGA "STOP A/B is active" PLC-SGE "de-select ext. STOP C" PLC-SGA "STOP C is active" PLC-SGE "de-select ext. STOP D" PLC-SGA "STOP D is active" PLC-SGE "de-select ext. STOP E" PLC-SGA "STOP E is active"

SGE de-select ext. STOP A

"Pulse cancellation" can be requested and executed using this SGE.

The safe functions currently active (SG/SBH/SN/SE) are not influenced by this SGE.

If one of the currently active limits is violated, an appropriate alarm is triggered.

The associated shutdown response cannot be activated because the pulses have already been cancelled. As soon as the stop request is cancelled via the SGE "de-select ext. STOP A" any queued shutdown responses become active.

If a stop request is active, SGA "STOP A/B is active" is set in the same way as it would be for an internally triggered STOP A.

0 signal: "Pulse cancellation" is requested

1 signal: "Pulse cancellation" is not requested

5.2 External STOPs

SGE de-select ext. STOP C

This SGE requests "braking with $n_{\text{set}} = 0$ " (braking at the current limit).
 When this stopping type is initiated, the safe braking ramp (SBR) is activated. In addition, the time set in MD36952/1352: $\$MA_/ \$MD_SAFE_STOP_SWITCH_TIME_C$ (transition time, STOP C to safe operating stop) is started.
 After this time has elapsed, the system automatically changes over to SBH.
 If a stop request is active, SGA "STOP C is active" is set in the same way as it would be for an internally triggered STOP C.

0 signal: "Braking with $n_{\text{set}} = 0$ " is requested
 1 signal: No request for "braking with $n_{\text{set}} = 0$ "

Note

Stopping with external STOP A (pulse cancellation) has a higher priority and can interrupt an external STOP C (braking at the current limit).

SGE de-select ext. STOP D

"Braking along a path" can be requested using this SGE.
 When ext. STOP D is triggered, the time set via MD 36953/1353 $\$MA_/ \$MD_SAFE_STOP_SWITCH_TIME_D$ (transition time, STOP D to safe operating stop) is started.
 After this time has elapsed, the system automatically changes over to SBH.
 If a stop request is active, SGA "STOP D is active" is set in the same way as it would be for an internally triggered STOP D.

0 signal: "Braking along a path" is requested
 1 signal: "Braking along the path" is not requested

Note

Stopping with an external STOP A (pulse cancellation) and external STOP C (braking at the current limit) has a higher priority and can interrupt an external STOP D (braking along a path).

SGE de-select ext. STOP E (from SW 6.4.15)

STOP E only results in a different response than a STOP D if the user has configured the ESR function (extended stopping and retraction) and the initiation of the ESR has been programmed depending on \$VA_STOPSI or \$A_STOPESI. If ESR is not active, then a STOP E behaves just like a STOP D. If the ESR function has been incorrectly configured, then a delay of up to 2 IPO clock cycles is incurred with respect to a STOP D until braking is initiated.

After these times have expired, braking is initiated at the current limit.

SGA STOP A/B is active

This signal indicates that STOP A/B is active.

The signal must be used for the forced checking procedure for external STOPS.

0 signal: STOP A/B is not active
1 signal: STOP A/B is active

SGA STOP C is active

This signal indicates that STOP C is active.

The signal must be used for the forced checking procedure for external STOPS.

0 signal: STOP C is not active
1 signal: STOP C is active

SGA STOP D is active

This signal indicates that STOP D is active.

The signal must be used for the forced checking procedure for external STOPS.

0 signal: STOP D is not active
1 signal: STOP D is active

SGA STOP E is active

This signal indicates that STOP E is active.

The signal must be used for the forced checking procedure for external STOPS.

0 signal: STOP E is not active
Otherwise: STOP E is active

Combinations for external STOPS

The following input bit combinations are obtained for the SGEs "de-select ext. STOP A", "de-select ext. STOP C", "de-select ext. STOP D" and "de-select ext. STOP E":

5.2 External STOPS

Table 5-12 Input bit combinations

SGE				
De-select external STOP E	De-select external STOP D	De-select external STOP C	De-select external STOP A	Description
x	x	x	0	"Pulse cancellation" is triggered
x	x	0	1	"Braking with $n_{set} = 0$ " is triggered
x	0	1	1	"Braking along a path" is triggered
1	1	1	1	External STOPS are not selected
0	1	1	1	"ESR" is triggered

5.2.2 Overview of the machine data for the "external STOPS" function

Overview of MD for 840D

Table 5-13 Overview of machine data for 840D

Number	Identifier
36977	\$MA_SAFE_EXT_STOP_INPUT[n]; n = 0 ... 3 n = associated stop 0 = "de-select ext. STOP A" (pulse cancellation) 1 = "de-select ext. STOP C" (braking, current limit) 2 = "de-select ext. STOP D" (braking along a path) 3 = "de-select ext. STOP E" (ESR)
36901	\$MA_SAFE_FUNCTION_ENABLE (enable safety-related functions) Bit 0: Enable SBH/SG Bit 3: Enable actual value synchronization Bit 4: Enable external ESR activation Bit 6: Enable external STOPS
36990	\$MA_SAFE_ACT_STOP_OUTPUT[n]; n = 0 ... 3 n = associated status (at signal level 1) 0 = "STOP A/B is active" 1 = "STOP C is active" 2 = "STOP D is active" 3 = "STOP DE is active"
Note: Data is described in Chapter 6.1, "Machine data for SINUMERIK 840D"	

Overview of MD for 611digital

Table 5-14 Overview of machine data for 611digital

Number	Identifier
1301	\$MD_SAFE_FUNCTION_ENABLE (enable safety-related functions) Bit 0: Enable SBH/SG Bit 3: Enable actual value synchronization Bit 4: Enable external ESR activation Bit 6: Enable external STOPS
Note: Data is described in Chapter 6.2, "Machine data for SIMODRIVE 611digital"	

5.3 Safe standstill (SH)

Description

The "safe standstill" function is based on the pulse cancellation function integrated in the drive modules of the SIMODRIVE 611A/D (start inhibit).

Reference: /PJ1/, Configuration Manual SIMODRIVE 611

A second shutdown path has been added to the existing pulse cancellation function on the SIMODRIVE 611digital Performance and Standard 2 closed-loop control modules.

The safe standstill function safely disconnects the energy feed to the motor in the event of a fault or in conjunction with a machine function.

The safe standstill is executed in two channels – i.e. by de-energizing an internal relay via a signal path of the drive bus on the one hand and by de-energizing terminal 663 on the drive module on the other. The two-channel feedback signal is realized, on one hand, via the drive bus, and on the other hand via the drive terminals AS1/AS2.

From NCU software release 6.3.30, the pulse enable can also be fed-back internally for all of the control modules. This means that it is not necessary to feed-back signals from terminal AS1/AS2.



Warning

If the "safe standstill" function or "STOP A" is activated, the motor can no longer generate any torque. This is the reason that potentially hazardous motion can occur, e.g. for the following:

- When an external force acts on the drive axes
- Vertical and inclined axes without weight equalization
- Axes that are moving (coasting down)
- Direct drives with low friction and low self-locking
- Notching torques (depending on the motor type, bearing design and friction characteristics, up to half a pole pitch in a direction that cannot be predicted).

Possible hazards must be clearly identified using a risk analysis that must be carried-out by the manufacturer. With an assessment, based on this risk analysis, it should be defined as to which additional measures are required, e.g. external brakes.

Features

The main features of the safe standstill functions are as follows:

- The motor cannot be started unintentionally or accidentally
- The energy feed to the motor is safely disconnected
- The motor is not electrically isolated from the drive module

Prerequisites

The SH function requires the following (refer to Chapter 3.5, "System prerequisites"):

- 611digital Performance control module
- 611digital Standard 2 control module
- High Standard
- High Performance
- Software version with SI

Selecting/de-selecting SH

The "safe standstill" function corresponds to an external STOP A. This makes it possible to explicitly select SH, not only using internal events (STOP A when a limit value is violated), but also via SGE.

- Safe standstill is activated after a STOP A.
- Safe standstill is automatically activated from every monitoring channel (through a single channel) when testing the shutdown paths.



Important

After the machine has been powered-up, the "safe standstill" function must always be tested for all of the axes/spindles by testing the shutdown path using Safety Integrated.

5.3 Safe standstill (SH)

5.3.1 Overview of the machine data for the SH function

Overview of MD for 840D

Table 5-15 Overview of machine data for 840D

Number	Identifier
36956	\$MA_SAFE_PULSE_DISABLE_DELAY
36957	\$MA_SAFE_PULSE_DIS_CHECK_TIME
36960	\$MA_SAFE_STANDSTILL_VELO_TOL
36976	\$MA_SAFE_PULSE_STATUS_INPUT
36986	\$MA_SAFE_PULSE_ENABLE_OUTPUT
Note: Data is described in Chapter 6.1, "Machine data for SINUMERIK 840D"	

Overview of MD for 611digital

Table 5-16 Overview of machine data for 611digital

Number	Identifier
1356	\$MD_SAFE_PULSE_DISABLE_DELAY
1357	\$MD_SAFE_PULSE_DIS_CHECK_TIME
1360	\$MD_SAFE_STANDSTILL_VELO_TOL
Note: Data is described in Chapter 6.2, "Machine data for SIMODRIVE 611digital"	

5.4 Safe operating stop (SBH)

Description

The SBH function safely monitors the standstill position (zero speed) of an axis/spindle in closed-loop position or speed control.

When SBH is active (SGA "SBH active" = 1), operating personnel can, for example, enter protected machine areas in the setting-up mode without first having to power-down the machine.

An incremental encoder is sufficient to implement this function. The actual position value of the axis/spindle is monitored for a change.

Features

The features of the SBH function are as follows:

- The axis remains in closed-loop control
- Parameterizable SBH tolerance window
- STOP B is the stop response after SBH has responded

Standstill tolerance

The standstill of the axis/spindle is monitored using an SBH tolerance window that is parameterized using the following machine data:

For 840D:

MD 36930: \$MA_SAFE_STANDSTILL_TOL

For 611digital:

MD 1330: \$MD_SAFE_STANDSTILL_TOL

Note

The width of the SBH tolerance window should be based on the standstill (zero speed) monitoring limit and should lie slightly above it. Otherwise, the standard monitoring functions of the control could be ineffective.

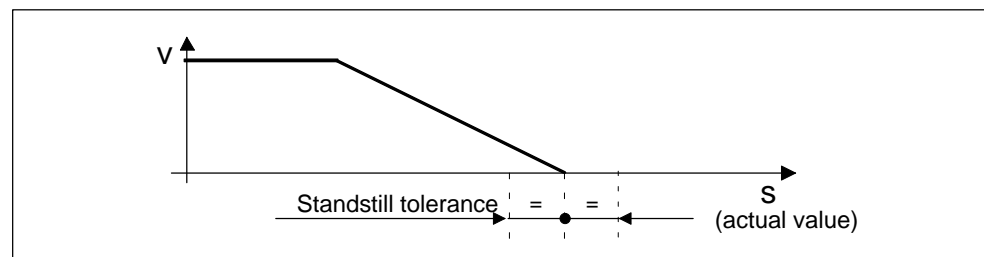

Fig. 5-12 Standstill tolerance

5.4 Safe operating stop (SBH)

Prerequisites

The following prerequisites must be fulfilled (refer to Chapter 3.5, "System requirements"):

- The option and functions must be enabled in the axis-specific machine data
- The SGEs "SBH/SG de-selection" and "SBH de-selection" must be supplied in the NCK and drive monitoring channel

5.4.1 Selecting/de-selecting the safe operating stop

Selecting SBH

The safe operating stop function is selected using the following SGEs:

Table 5-17 Selecting/de-selecting SBH

SGE		SGA	Meaning
SBH/SG de-selection	SBH de-selection	SBH active ¹⁾	
= 1	x ²⁾	0	SBH and SG are de-selected
= 0	= 0	1	SBH is selected
= 0	= 1	0	SG is selected (refer to Chapter 5.5, "Safely-reduced speed (SG)"),

Note:
x -> Any signal state
1) For SINUMERIK 840D, SG2 and SG4 can be finely graduated using the SG override (refer to Chapter 5.5.5 "Override for safely-reduced speed").
The active SG stage is displayed using SGA "SGA active bit 0" and "SGA active bit 1".

Note

If "safely-reduced speed" was not active prior to the selection of SBH, any moving axis/spindle is stopped with STOP B/A.

The actual status of the function is displayed using the SGA "SBH active".

The SGEs and SGAs are described in Chapter 5.9 "Safety-related input/output signals (SGE/SGA)".

Internal control request for SBH

When the SG or SE responds (STOP C or D), the drive is internally switched to the safe operating stop state in the control. In such cases, the external circuit of the SGEs (SBH/SGH de-selection and SBH de-selection) is ignored and both are internally set to "0".

Selecting SBH from SG

The changeover from safely-reduced speed to safe operating stop is initiated using the SGE "SBH de-selection". A delay time that is parameterized in the following machine data is simultaneously started with the changeover to SBH ("signal "SBH de-selection"=0):

for 840D

MD 36951: \$MA_SAFE_VELO_SWITCH_DELAY

for 611digital

MD 1351: \$MD_SAFE_VELO_SWITCH_DELAY

SBH is activated as soon as the delay time expires.

Note

If the SBH function is selected while an axis/spindle is moving, the machinery construction OEM must initiate the braking process such that the axis/spindle is in position – i.e. stationary – after the delay time has expired. This can be performed automatically using the "setpoint speed limiting" function. If the axis moves out of the standstill tolerance window after the delay has expired, an alarm is generated (for 840D: 27010, for 611digital: 300907) and STOP B/A initiated!

5.4 Safe operating stop (SBH)

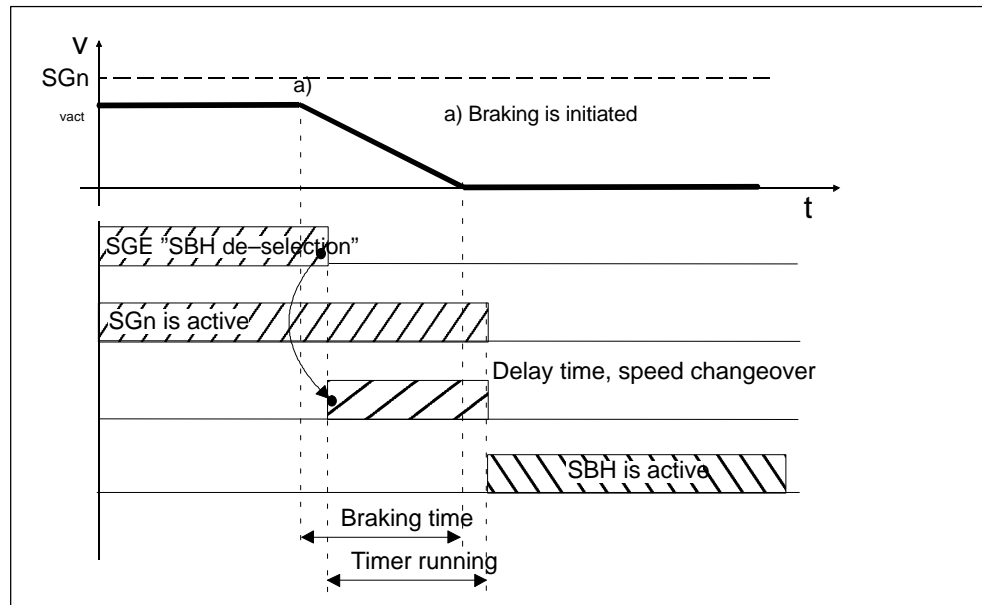

Fig. 5-13 Timing when SBH is selected from SG

De-selecting SBH

Safe operating stop can be de-selected using SGE "SBH/SG de-selection" (= "1" signal); this results in a general de-activation of SBH and SG. The SBH function is also de-selected when the SG function is selected using the SGE "SBH de-selection".

Note

The delay time must be selected as a function of the distance to the hazardous location. The speeds to be taken into account in this respect are stipulated in Standard DIN EN999.

SGA "SBH active"

If this SGA is set, then safe operating stop (SBH) is active. This means that the axis is safely monitored for zero speed. This SGA can be used, for example, to implement protective door interlocking functions.

Configuring NCK-SGAs

The NCK-SGA "SBH active" is configured using the following machine data:

for 840D

MD 36981: \$MA_SAFE_SS_STATUS_OUTPUT

5.4.2 Effects when the limit is exceeded for SBH



Warning

If the "safe operating stop" function is activated, when a fault situation occurs, the axis mechanical system can exhibit jerky, uneven motion. The magnitude of this movement depends on the following parameters:

- Design of the mechanical system and ratio between the motor and mechanical system
- Speed and acceleration capability of the motor
- Magnitude of the selected monitoring clock cycle
- Magnitude of the selected SBH tolerance window

If the axis/spindle is being monitored (SGA "SBH active"=1) and leaves, for example, the standstill tolerance window as the result of an external influence or an undefined setpoint input, the effects are as follows:

Effects

- The axis switches to STOP A/B configured using the following MDs:
 - for 840D
36956: \$MA_SAFE_PULSE_DISABLE_DELAY
 - for 611digital
1356: \$MD_SAFE_PULSE_DISABLE_DELAY
 - and
 - for 840D
36960: \$MA_SAFE_STANDSTILL_VELO_TOL
 - for 611digital
1360: \$MD_SAFE_STANDSTILL_VELO_TOL
- An alarm is generated (for 840D: 27010, for 611digital: 300907)

5.4 Safe operating stop (SBH)

Timing when the limit value is exceeded

If the safe operating stop function is active, when the limit value is exceeded the response is as follows:

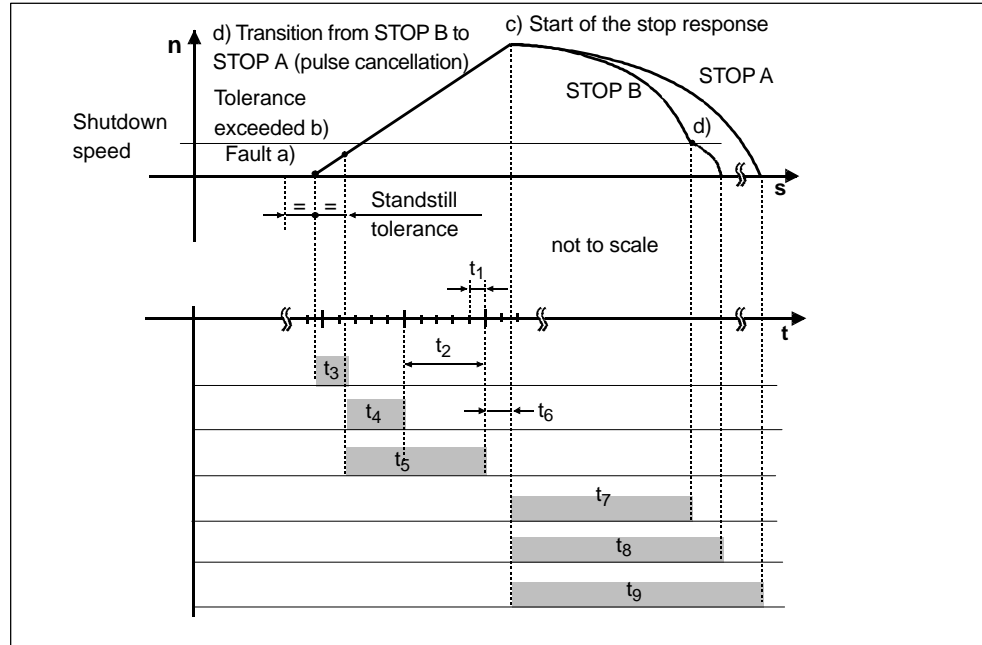

Fig. 5-14 Timing when the limit value is exceeded for SBH

Table 5-18 Explanation of the diagram

Time	Explanation
t ₁	The position control clock cycle, defined by the following MDs: For 840D: MD 10050: \$MN_SYSCLOCK_CYCLE_TIME MD 10060: \$MN_POSCTRL_SYSCLOCK_TIME_RATIO
t ₂	Monitoring clock cycle, defined by the following MDs: For 840D: MD 10090: \$MN_SAFETY_SYSCLOCK_TIME_RATIO For 611digital: MD1300: \$MD_SAFETY_CYCLE_TIME
t ₃	Time until the standstill tolerance value is exceeded
t ₄	Time until it has been detected that the standstill tolerance value has been exceeded (maximum 1 monitoring clock cycle)
t ₅	Response time required to initiate the configured stop response (maximum 2 monitoring clock cycles)
t ₆	Time until the stop response sequence starts (time = 0, dependent on the configured stop response, refer to Chapter 2, "Stop responses")
t ₇	Time required to reach the shutdown speed for STOP B.
t ₈	Time required to stop the axis for a STOP B.

Table 5-18 Explanation of the diagram

Time	Explanation
t_9	Time required to stop the axis for a STOP A.
Note: Each axis must be measured during commissioning (start-up) to determine the distance that it travels between the limit switch being violated and it coming to a standstill.	

5.4.3 Overview of the machine data for the SBH function

Overview for 840D

Table 5-19 Overview of machine data for 840D

Number	Identifier
36901	\$MA_SAFE_FUNCTION_ENABLE
36930	\$MA_SAFE_STANDSTILL_TOL
36951	\$MA_SAFE_VELO_SWITCH_DELAY
36956	\$MA_SAFE_PULSE_DISABLE_DELAY
36960	\$MA_SAFE_STANDSTILL_VELO_TOL
36970	\$MA_SAFE_SVSS_DISABLE_INPUT
36971	\$MA_SAFE_SS_DISABLE_INPUT
36980	\$MA_SAFE_SVSS_STATUS_OUTPUT
36981	\$MA_SAFE_SS_STATUS_OUTPUT
Note: Data is described in Chapter 6.1, "Machine data for SINUMERIK 840D"	

Overview for 611digital

Table 5-20 Overview of machine data for 611digital

Number	Identifier
1301	\$MD_SAFE_FUNCTION_ENABLE
1330	\$MD_SAFE_STANDSTILL_TOL
1351	\$MD_SAFE_VELO_SWITCH_DELAY
1356	\$MD_SAFE_PULSE_DISABLE_DELAY
1360	\$MD_SAFE_STANDSTILL_VELO_TOL
Note: Data is described in Chapter 6.2, "Machine data for SIMODRIVE 611digital"	

5.5 Safely-reduced speed

Description

The purpose of the SG (safely-reduced speed) function is to safely monitor the load-side speed of an axis/spindle.

The actual speed of the axis/spindle is cyclically compared in the monitoring clock cycle with the speed limit value selected using SGEs. The speed limit values are defined in the following machine data:

For 840D:

MD 36931: \$MA_SAFE_VELO_LIMIT[n]

For 611digital:

MD 1331: \$MD_SAFE_VELO_LIMIT[n]

The speed limit values for SG1, SG2, SG3 or SG4 allow various applications/operating states on the machine to be monitored. The safely-reduced speed function can therefore be used to implement protective measures for the operating personnel and machine in the setting-up mode or also in automatic operation.



Important

For selector gearboxes, it is important to select the correct gear ratio!

Features

The features of the SG function are as follows:

- Load-side speed limit values are safely monitored
- Monitoring limit values are adapted to various operating states (e.g. test, setting-up, automatic modes)
- Configurable stop response when the SG responds

Prerequisites

The following prerequisites must be fulfilled (refer to Chapter 3.5, "System prerequisites"):

- The option and functions must be enabled in the axis-specific machine data
- The SGEs "SBH/SG de-selection" and "SBH de-selection" must be configured

Specifying velocities and speeds

The requirements regarding speeds and velocities that are stipulated for individual processes (milling, turning, grinding, etc.) vary depending on the different C Standards. For example, the following could be specified for the setting-up mode:

"Safely-reduced speed" with 2m/min for feed drives and 50 RPM for spindle drives or standstill within 2 revolutions.

The machinery construction OEM must parameterize SI in such a way as to ensure full compliance with the EC Machinery Directive. The relevant standards provide the necessary guidelines and support.

Quantities that influence the parameterization include, e.g. the drive dynamic response, the set parameters with their delay times, electrical and mechanical ratios and all of the mechanical properties and characteristics. The interrelationships between the drive dynamic response and internal delay times of SI are shown in Fig. 5-16 "Timing when exceeding the limit value for SG".

Speed monitoring, encoder limit frequency

When SBH/SG is active in a configuration with a 1-encoder, the speed is monitored to ensure that it does not exceed a maximum encoder limit frequency. An appropriate alarm is output if this limit is exceeded.

Depending on the number of encoder pulses, the limit values are as follows for a ratio of e.g.

Motor : Load = 1 : 1

Table 5-21 Encoder limit frequency and speed

Encoder pulses/rev.	Speed at maximum encoder limit frequency		
	200 kHz	300 kHz	420 kHz
2 048	5 800 RPM	8 700 RPM	12 300 RPM
1 024	11 600 RPM	17 400 RPM	24 600 RPM
512	22 200 RPM	34 800 RPM	49 200 RPM

Parameterizable encoder limit frequency (from SW 6.3.30)

Machine data 36926: \$MA_SAFE_ENC_FREQ_LIMIT can be used to set a limit frequency. The maximum value is 420 kHz, the lower limit value and standard value is 300 kHz.

This MD is set-up for each monitoring channel. MD 1326: \$MD_SAFE_ENC_FREQ_LIMIT is effective in the drive.).

The values in this MD are incorporated in the crosswise data comparison of the monitoring channels.

5.5 Safely-reduced speed

Note

Changes to this MD may only be made, carefully taking into account the prevailing conditions.

This functionality is **only** supported by 611digital Performance 2 control modules, High Standard and High Performance.

If the MD value is changed for an axis with a Standard 2 or a Performance 1 control module, this results in Alarm 27033 "Axis %1 Defect in a monitoring channel, Code %2, Values: NCK %3, Drive %4". The 300 kHz limit still applies to these axes.

Limitations/constraints

The following limitations/constraints apply:

1. Cables to be used:
Siemens cable, Order No. [MLFB]: 6FX2002-2CA31-1CF0
2. Maximum permissible encoder cable length: 20 m
3. Encoder characteristics: "–3dB cutoff frequency" greater than or equal to 500 kHz
Examples of the encoders used:
ERA 180 with 9000 pulses/rev and ERA 180 with 3600 pulses/rev from Heidenhain
4. The amplitude monitoring that is active up to 420 kHz.

5.5.1 Selecting/de-selecting safely reduced speed

Selecting SG

The following SGEs are used to select SG:

Table 5-22 Selecting/de-selecting SG

SGE		Meaning
SBH/SG de-selection	SBH de-selection	
= 1	x	SBH and SG are de-selected
= 0	= 0	SBH is selected (refer to Chapter 5.4, "Safe operating stop (SBH)")
= 0	= 1	SG is selected
Note: x -> Any signal state		

Note

The actual status of the function is displayed using the SGA "SBH/SG active" and SGA "SBH active".

Before activating the SG function it must be ensured that the speed of the axis/spindle is lower than the selected speed limit value. If it is higher, an alarm is generated that causes the drive to be shut down.

The SGEs and SGAs are described in Chapter 5.9 "Safety-related input/output signals (SGE/SGA)".

Selecting speed limit values

The maximum permissible speed of an axis/spindle in the setting-up mode is defined for individual machine types in the C Standards (product standards). The machinery construction OEM is responsible for ensuring that the correct speed limit value is selected depending on the operating mode and the application.

The required speed limit is selected as follows by combining the following SGEs:

Table 5-23 Selecting speed limit values for SGs

SGE		Meaning
SG selection Bit 1	SG selection Bit 0	
= 0	= 0	Speed limit value for SG1 active
= 0	= 1	Speed limit value active for SG2 ¹⁾
= 1	= 0	Speed limit value for SG3 active
= 1	= 1	Speed limit value active for SG4 ¹⁾
Note: 1) For SINUMERIK 840D, the SG limit value SG2 and SG4 can be finely graduated using the SG override (refer to Chapter 5.5.4 "Override for safely-reduced speed"). The active SG stage is displayed using SGA "SGA active bit 0" and "SGA active bit 1".		

5.5 Safely-reduced speed

Changing-over the speed limit values

A changeover from a lower to a higher speed limit value takes effect instantaneously without any delay.

When changing-over from a higher to a lower limit value, then a delay time is started that is parameterized using the machine data (refer to Fig. 5-15, "Timing when changing-over from a higher to a lower speed limit").

For 840D:

MD 36951: \$MA_SAFE_VELO_SWITCH_DELAY

For 611digital:

MD 1351: \$MD_SAFE_VELO_SWITCH_DELAY

The axis/spindle must be braked sufficiently during the delay time so that it has reached the reduced speed that is below the new limit value when the delay time expires. However, if the actual speed is higher than the new limit value when the time has expired, an appropriate alarm is output with the configurable stop response.

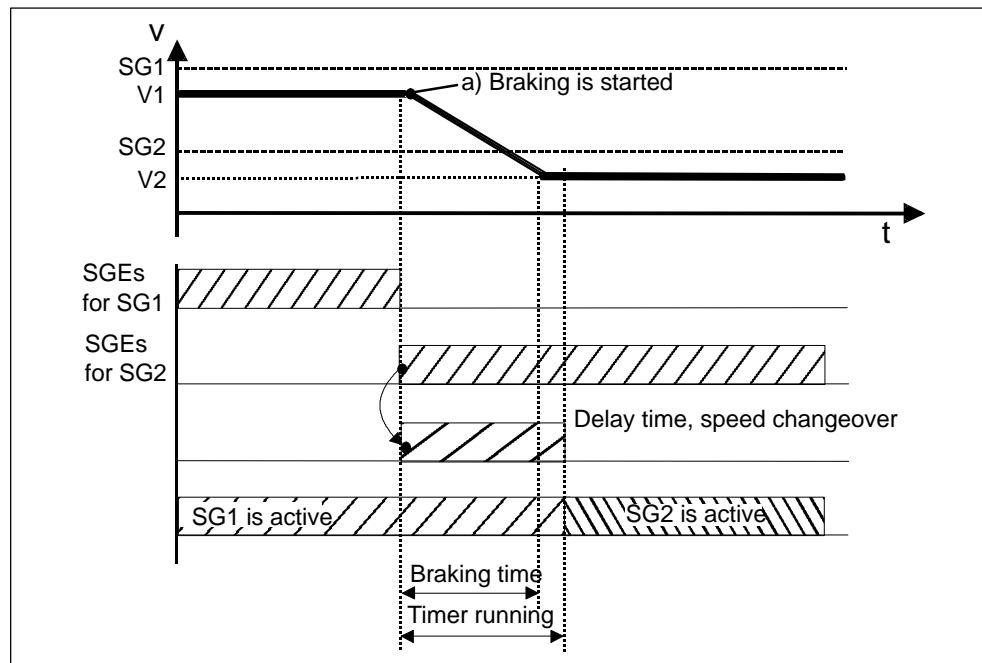

Fig. 5-15 Timing when changing-over from a higher to a lower speed limit.

De-selecting SG

The SG function can be de-selected at any speed by activating the SGE "SBH/SG de-selection".



Warning

The delay time must also be selected as a function of the distance to the hazardous location. The speeds to be taken into account (speed at which hands/arms are moved to appropriately arrange protective devices/guards) are specified in Standard DIN EN999.

5.5.2 Effects when the limit value is exceeded for SG

Configurable stop response

When the selected speed limit value is violated, a stop response configured in the following machine data is generated:

For 840D:

MD 36961: \$MA_SAFE_VELO_STOP_MODE

MD 36963: \$MA_SAFE_VELO_STOP_REACTION[n]

For 611digital:

MD 1361: \$MD_SAFE_VELO_STOP_MODE

MD 1363: \$MD_SAFE_VELO_STOP_REACTION[n]

Note

- An alarm is displayed (for 840D: 27011, for 611digital: 300914). After the cause of the fault has been removed, the alarm can be acknowledged with RESET. The monitoring function is then again active.
- Depending on the selected monitoring clock cycle, the dynamic drives may cause a brief increase in speed on the monitored axis/spindle before the stop response sequence starts.
- For traversing modes which use a transformation with singularity points (e.g. 5-axis transformation and TRANSMIT), relatively high axial speeds occur at these points. These can initiate stop responses even though the cartesian motion of the tool center point (TCP) lies below the selected speed limit value. The monitoring functions provided by SI are basically axis-specific. This means that it is not possible to directly monitor the TCP.

5.5 Safely-reduced speed

Timing when the limit value is exceeded

When the safely-reduced speed function is active, then the timing is as follows when the limit value is violated:

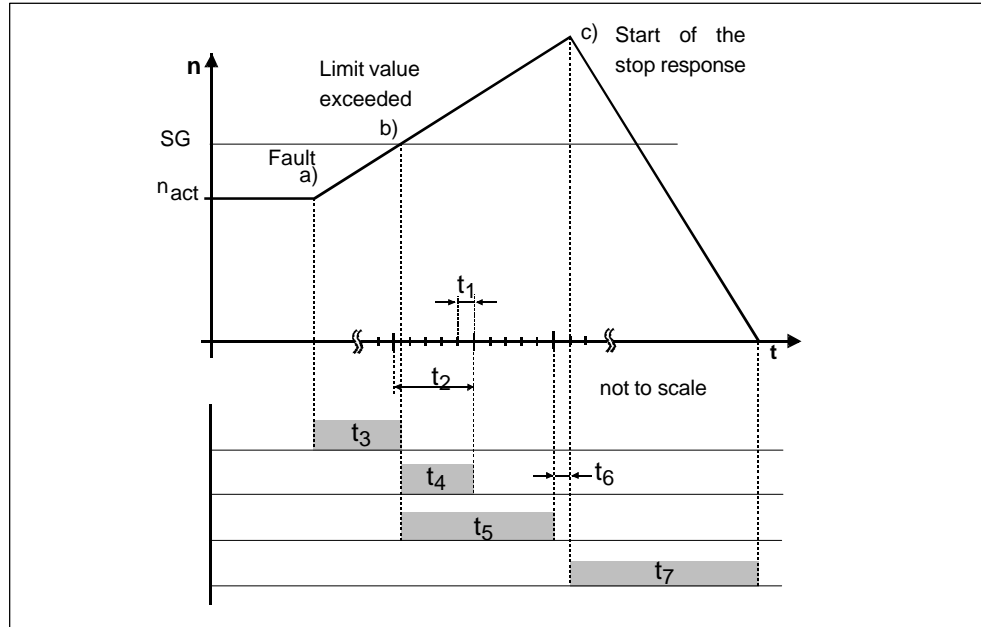

Fig. 5-16 Timing when the limit value is exceeded for SG

Table 5-24 Explanation of the diagram

Time	Explanation
t ₁	The position control clock cycle, defined by the following MDs: MD 10050: \$MN_SYSCLOCK_CYCLE_TIME MD 10060: \$MN_POSCTRL_SYSCLOCK_TIME_RATIO
t ₂	Monitoring clock cycle, defined by the following MDs: MD 10090: \$MN_SAFETY_SYSCLOCK_TIME_RATIO MD1300: \$MD_SAFETY_CYCLE_TIME for 611digital:
t ₃	Time between an error occurring and a limit value being reached
t ₄	Time until a limit value violation is detected (maximum 1.5 monitoring clock cycles)
t ₅	Response time required to initiate the configured stop response (maximum 2.5 monitoring clock cycles)
t ₆	Time until the stop response sequence starts (time = 0, dependent on the configured stop response, refer to Chapter 2, "Stop responses")
t ₇	Time required to bring the axis to a standstill. This time and thus the residual distance traveled by the axis is determined by the axis design (motor, mass, friction, ...) and the configured stop response (STOP C is faster than STOP D).
<p>Note:</p> <p>Each axis must be measured during commissioning (start-up) to determine the distance that it travels between the limit switch being violated and it coming to a standstill.</p>	

5.5.3 SG specific stop responses

Configurable SG specific stop responses

Using the configurable SG-specific stop response, a suitable braking behavior can be set for every SG stage in-line with the application when the particular speed limit value is exceeded.

For example, when:

SETTING-UP, the SG stage SG2 can be active with the configured stop response STOP C and

in the AUTOMATIC mode, the SG stage SG4 with the configured stop response STOP D.

Activating

The function is active if MD 36961/1361: \$MA_/\$MD_SAFE_VELO_STOP_MODE = 5.

Setting the configurable SG-specific stop responses

The SG-specific stop responses can be set using the following machine data:

For 840D:

MD 36963: \$MA_SAFE_VELO_STOP_REACTION[n](SG-specific stop response)

For 611digital:

MD 1363: \$MD_SAFE_VELO_STOP_REACTION[n]

5.5.4 Override for safely-reduced speed

General information

16 SG override stages for the limit values of safely-reduced speeds 2 and 4 using SGEs. This means that the limit values for SG2 and SG4 can be more finely graduated.

Using the following machine data, an override stage can be assigned factors of between 1 and 100%:

For 840D:

MD 36932: \$MA_SAFE_VELO_OVR_FACTOR[n]

(override factor for safely-reduced speed)

For 611digital:

MD 1332: \$MD_SAFE_VELO_OVR_FACTOR[n]

5.5 Safely-reduced speed

Application example

For grinding applications, the limit value for the safely-reduced speed can be adjusted to the variations in the grinding wheel peripheral speed using the SG override.

Activating

The following prerequisites must be fulfilled before the function can be used:

- The function is enabled using MD 36901(MD 1301):
\$MA(\$MD)_SAFE_FUNCTION_ENABLE, bit 5
- The SBH/SG function is enabled
- The required SGEs "SG override selection bits 3, 2, 1, 0" have either been completely or partially configured
- The SG override factors have been entered into the appropriate machine data
- Safely-reduced speed 2 or 4 has been activated

Changing-over an SG override

SG override values are changed-over subject to the same conditions as those that apply to speed limit values.

Table 5-25 Changing-over SG override stages

Changeover	Description
From lower to higher	Instantaneous
From higher to lower	The time parameterized using MD 36951/MD 1351 is started. The axis/spindle must be braked within this delay time.
Note: Refer to Chapter 5.5.1, "Selecting/de-selecting safely reduced speed"	

Note

Changing between SGEs "SG override selection, bits 3, 2, 1, 0" continuously and quickly may initiate a STOP F.

Selecting an SG override

The active speed limit value (SG1, 2, 3 or 4) is selected using SGEs "SG selection bits 1 and 0". The desired override is selected by combining SGEs "SG override selection bits 3, 2, 1 and 0". The override is only effective for the speed limit value for SG2 and SG4.

Table 5-26 Selecting the SG override for safely-reduced speed

SG selection Bit 1	SG selection Bit 0	SGE				Meaning
		SG override selection Bit 3	SG override selection Bit 2	SG override selection Bit 1	SG override selection Bit 0	
= 0	= 0	x	x	x	x	Speed limit value for SG1 active
= 0	= 1	= 0	= 0	= 0	= 0	Speed limit value for SG2 active with override stage 0
–	–	= 0	= 0	= 0	= 1	... with override stage 1
–	–	= 0	= 0	= 1	= 0	... with override stage 2
–	–	= 0	= 0	= 1	= 1	... with override stage 3
–	–	= 0	= 1	= 0	= 0	... with override stage 4
–	–	= 0	= 1	= 0	= 1	... with override stage 5
–	–	= 0	= 1	= 1	= 0	... with override stage 6
–	–	= 0	= 1	= 1	= 1	... with override stage 7
–	–	= 1	= 0	= 0	= 0	... with override stage 8
–	–	= 1	= 0	= 0	= 1	... with override stage 9
–	–	= 1	= 0	= 1	= 0	... with override stage 10
–	–	= 1	= 0	= 1	= 1	... with override stage 11
–	–	= 1	= 1	= 0	= 0	... with override stage 12
–	–	= 1	= 1	= 0	= 1	... with override stage 13
–	–	= 1	= 1	= 1	= 0	... with override stage 14
–	–	= 1	= 1	= 1	= 1	... with override stage 15
= 1	= 0	x	x	x	x	Speed limit value for SG3 active
= 1	= 1	= 0	= 0	= 0	= 0	Speed limit value for SG4 active with override stage 0
–	–	= 0	= 0	= 0	= 1	... with override stage 1
–	–	= 0	= 0	= 1	= 0	... with override stage 2
–	–	= 0	= 0	= 1	= 1	... with override stage 3
–	–	= 0	= 1	= 0	= 0	... with override stage 4
–	–	= 0	= 1	= 0	= 1	... with override stage 5
–	–	= 0	= 1	= 1	= 0	... with override stage 6
–	–	= 0	= 1	= 1	= 1	... with override stage 7
–	–	= 1	= 0	= 0	= 0	... with override stage 8
–	–	= 1	= 0	= 0	= 1	... with override stage 9
–	–	= 1	= 0	= 1	= 0	... with override stage 10

5.5 Safely-reduced speed

Table 5-26 Selecting the SG override for safely-reduced speed

SG selection Bit 1	SG selection Bit 0	SG override selection Bit 3	SG override selection Bit 2	SG override selection Bit 1	SG override selection Bit 0	Meaning
–	–	= 1	= 0	= 1	= 1	... with override stage 11
–	–	= 1	= 1	= 0	= 0	... with override stage 12
–	–	= 1	= 1	= 0	= 1	... with override stage 13
–	–	= 1	= 1	= 1	= 0	... with override stage 14
–	–	= 1	= 1	= 1	= 1	... with override stage 15

x: Signal state is optional since override values are not effective for SG1 and SG3

Configuring NCK-SGEs

NCK-SGEs (override selection bits 3, 2, 1, 0) are configured using the following machine data:

For 840D:

MD 36978: \$MA_SAFE_OVR_INPUT[n]

(input assignment for override selection)

Defining SG override factors

The SG override factors themselves (percentage values) are defined using the following machine data:

For 840D:

MD 36932: \$MA_SAFE_VELO_OVR_FACTOR[n]

(override factor, safely-reduced speed)

For 611digital:

MD 1332: \$MD_SAFE_VELO_OVR_FACTOR[n]

5.5.5 Example: Override for safely-reduced speed

Task

When safely-reduced speeds are selected, the speed limit values must be set as follows.

Table 5-27 Application example of how override is used for safely-reduced speed

SGE SG selection		SGE override selection				Effective speed limit value	
Bit 1	Bit 0	Bit 3	Bit 2	Bit 1	Bit 0		Assumptions for the example
0	0	x	x	x	x	Limit value 1	1000 mm/min
0	1	0	0	0	0	Limit value 2 with override stage 0	100 % = 2000 mm/min
–	–	0	0	0	1	Limit value 2 with override stage 1	80 % = 1600 mm/min
–	–	0	0	1	0	Limit value 2 with override stage 2	50 % = 1000 mm/min
–	–	0	0	1	1	Limit value 2 with override stage 3	30 % = 600 mm/min
1	0	x	x	x	x	Limit value 3	4000 mm/min
1	1	0	0	0	0	Limit value 4 with override stage 0	100 % = 5000 mm/min
–	–	0	0	0	1	Limit value 4 with override stage 1	80 % = 4000 mm/min
–	–	0	0	1	0	Limit value 4 with override stage 2	50 % = 2500 mm/min
–	–	0	0	1	1	Limit value 4 with override stage 3	30 % = 1500 mm/min

Notes:
 x: Signal status is optional since override values are not effective for SG1 and SG3
 SGEs "SG override selection bit 3 and bit 2" are not required to select an SG override – i.e. they do not need to be configured (they are internally set to "0").

Assumptions for the example

- The example applies to the 1st axis on a SINUMERIK 840D/SIMODRIVE611digital.
- Defining the SGEs in the NCK monitoring channel

Logical slot for the terminal block:	6
Slot number of the sub-module for SGEs:	4
I/O number for signal, SG selection, bit 1:	2
I/O number for signal, SG selection, bit 0:	1
I/O number for signal, override, bit 1:	4
I/O number for signal, override, bit 0:	3

5.5 Safely-reduced speed

Defining machine data

Table 5-28 Supplying MDs for the speed limit values

Limit value	for 840D		for 611digital	
	MD No.	Value	MD No.	Value
SG1	36931[0]	1000	1331[0]	1000
SG2	36931[1]	2000	1331[1]	2000
SG3	36931[2]	4000	1331[2]	4000
SG4	36931[3]	5000	1331[3]	5000

Table 5-29 Supplying the MDs for the SGEs

Signal SGE	Assignment		Comment
	MD No.	Value	
SG selection, bit 1	36972[1]	01 06 04 02	
SG selection, bit 0	36972[0]	01 06 04 01	
SG override selection, bit 3	36978[3]	00 00 00 00	Not configured
SG override selection, bit 2	36978[2]	00 00 00 00	Not configured
SG override selection, bit 1	36978[1]	01 06 04 04	
SG override selection, bit 0	36978[0]	01 06 04 03	

Table 5-30 Supplying MDs for override factors

Override	for 840D		for 611digital	
	MD No.	Value	MD No.	Value
0	36932[0]	100	1332[0]	100
1	36932[1]	80	1332[1]	80
2	36932[2]	50	1332[2]	50
3	36932[3]	30	1332[3]	30

5.5.6 Application example for SG

Please refer to Chapter 10.3.9 "SG changeover" for an example of safely-reduced speed.

Please refer to Chapter 10.15 for using selector gearboxes in conjunction with SG and the general information and instructions regarding encoder mounting conditions.

5.5.7 Overview of the machine data for the SG function

Overview of MD for 840D

Table 5-31 Overview of machine data for 840D

Number	Identifier
36901	\$MA_SAFE_FUNCTION_ENABLE
36921	\$MA_SAFE_ENC_GEAR_DENOM[n]
36910	\$MA_SAFE_ENC_SEGMENT_NR
36911	\$MA_SAFE_ENC_MODULE_NR
36912	\$MA_SAFE_ENC_INPUT_NR
36915	\$MA_SAFE_ENC_TYPE
36916	\$MA_SAFE_ENC_IS_LINEAR
36917	\$MA_SAFE_ENC_GRID_POINT_DIST
36918	\$MA_SAFE_ENC_RESOL
36920	\$MA_SAFE_ENC_GEAR_PITCH
36921	\$MA_SAFE_ENC_GEAR_DENOM[n]
36922	\$MA_SAFE_GEAR_NUMERA[n]
36925	\$MA_SAFE_ENC_POLARITY
36931	\$MA_SAFE_VELO_LIMIT[n]
36932	\$MA_SAFE_VELO_OVR_FACTOR[n]
36951	\$MA_SAFE_VELO_SWITCH_DELAY
36961	\$MA_SAFE_VELO_STOP_MODE
36963	\$MA_SAFE_VELO_STOP_REACTION[n]
36970	\$MA_SAFE_SVSS_DISABLE_INPUT
36972	\$MA_SAFE_VELO_SELECT_INPUT[n]
36974	\$MA_SAFE_GEAR_SELECT_INPUT[n]
36980	\$MA_SAFE_SVSS_STATUS_OUTPUT

5.5 Safely-reduced speed

Table 5-31 Overview of machine data for 840D

Number	Identifier
36982	\$MA_SAFE_VELO_STATUS_OUTPUT [n]
Note: Data is described in Chapter 6.1, "Machine data for SINUMERIK 840D"	

Overview of MD for 611digital

Table 5-32 Overview of machine data for 611digital

Number	Identifier
1301	\$MD_SAFE_FUNCTION_ENABLE
1316	\$MD_SAFE_ENC_CONFIG
1317	\$MD_SAFE_ENC_GRID_POINT_DIST
1318	\$MD_SAFE_ENC_RESOL
1320	\$MD_SAFE_ENC_GEAR_PITCH
1321	\$MD_SAFE_ENC_GEAR_DENOM[n]
1322	\$MD_SAFE_ENC_GEAR_NUMERA[n]
1331	\$MD_SAFE_VELO_LIMIT[n]
1332	\$MD_SAFE_VELO_OVR_FACTOR [n]
1351	\$MD_SAFE_VELO_SWITCH_DELAY
1361	\$MD_SAFE_VELO_STOP_MODE
1363	\$MD_SAFE_VELO_STOP_REACTION[n]
Note: Data is described in Chapter 6.2, "Machine data for SIMODRIVE 611digital"	

5.6 Safe software limit switches (SE)

Note

The function "safe software limit switch" (SE) is also known as "safe limit position".

Description

The "safe software limit switch" function (SE) can be used to implement protective functions for operating personnel and machinery or limiting the working zone/protective zone for specific axes. For example, this function can replace hardware limit switches.

Two safe software limit switches (SE1 and SE2) are available for each axis. If the SE function is active, limit switch position pair SE1 or SE2 can be selected as a function of SGE "SE selection".

Defining the upper and lower limit values

The position limit values for the software limit switch position pairs 1 and 2 are defined in the following machine data:

For 840D:

MD 36934: \$MA_SAFE_POS_LIMIT_PLUS[n]

MD 36935: \$MA_SAFE_POS_LIMIT_MINUS[n]

For 611digital:

MD 1334: \$MD_SAFE_POS_LIMIT_PLU[n]

MD 1335: \$MD_SAFE_POS_LIMIT_MINUS[n]

Note

The upper and lower position limit values must be selected so that when the axis is traversing in this direction, the software limit switches – that are used as standard – are first reached.

Features

The most important features include:

Software limit switches are safely defined and evaluated as a software function

Configurable stop response when software limit switches are passed

The stop response is implemented internally in the software (and is therefore faster than a hardware limit switch response) when software limit switches are passed (i.e. actuated)

5.6 Safe software limit switches (SE)

Prerequisites

The "safe software limit switch" function is dependent on the following prerequisites being fulfilled (refer to Chapter 3.5, "System prerequisites"):

- The "safe software limit switch" function must be enabled
- The axis/axes must have been safely referenced (user agreement)
- SGE "SE selection" must be supplied (configured) in both channels



Warning

"Safe software limit switches" are only effective if the user agreement has been given.

5.6.1 Effects when an SE responds



Warning

The SE function does not predictively monitor the SW (software) limit switches. This means that the axis stops after passing the limit position. The distance traveled after the SE is dependent on:

- How the function was parameterized (monitoring clock cycle, stop response, ...)
- The actual speed
- The design of the axis

Configurable stop responses

When an axis passes (actuates) a "safe software limit switch", a stop response configured in the following machine data is generated:

For 840D:

MD 36962: \$MA_SAFE_POS_STOP_MODE

For 611digital:

MD 1362: \$MD_SAFE_POS_STOP_MODE

The user can select either STOP C, D or STOP E.

Effect

- The configured stop response is initiated
- The relevant alarm is displayed

Acknowledging and moving away

- Traverse the axis into a range in which the monitoring does not respond (refer to a description of Alarm 27012 "Safe end position exceeded" in Chapter 6 "Alarms"). The user agreement must be withdrawn (SE is then de-activated).
or
change over to the other "safe software limit switch".
- Acknowledge the fault message according to the configured software response (refer to Chapter 5.1, "Basic mechanisms of SI functions")

Timing when a safe software limit switch is actuated

If the "safe software limit switch" function is active, the system timing is as follows when the software limit switch is actuated (passed):

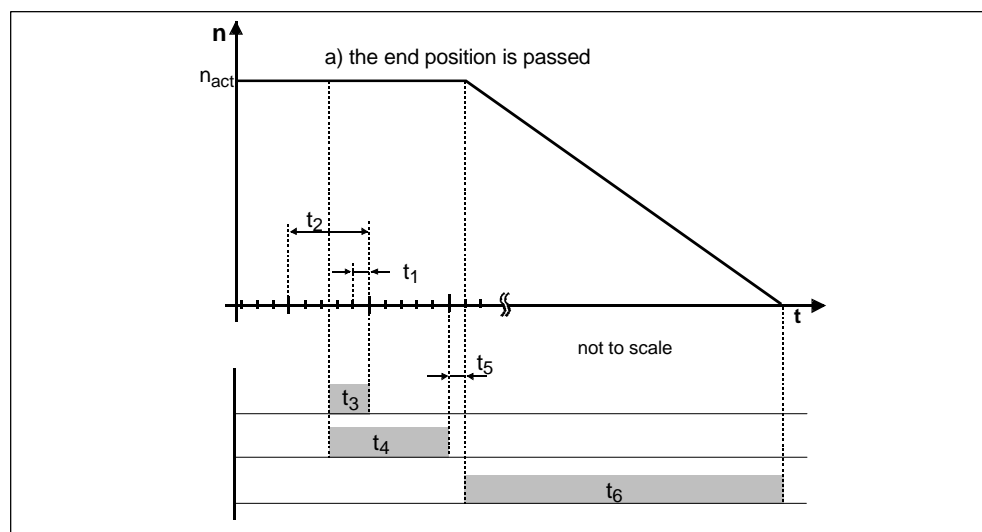

Fig. 5-17 Timing when a software limit switch is actuated

Table 5-33 Explanation of the diagram

Time	Explanation
t_1	The position control clock cycle, defined by the following MDs: For 840D: MD 10050: \$MN_SYSCLOCK_CYCLE_TIME MD 10060: \$MN_POSCTRL_SYSCLOCK_TIME_RATIO
t_2	Monitoring clock cycle, defined by the following MDs: For 840D: MD 10090: \$MN_SAFETY_SYSCLOCK_TIME_RATIO For 611digital: MD1300: \$MD_SAFETY_CYCLE_TIME
t_3	Time until it has been detected that the limit switch has been actuated (maximum 1 monitoring clock cycle)
t_4	Delay until the configured stop response is output (maximum 2 monitoring clock cycles)

5.6 Safe software limit switches (SE)

Table 5-33 Explanation of the diagram

Time	Explanation
t ₅	Delay until the configured stop response becomes effective (time = 0, depends on the configured stop response, refer to Chapter 2, "Stop responses")
t ₆	Time required to bring the axis to a standstill. This time and therefore the residual distance traveled by the axis is determined by the axis design (motor, mass, friction, ...) and the configured stop response (STOP C is faster than STOP D).
Note: Each axis must be measured during commissioning (start-up) to determine the distance that it travels between the limit switch being violated and it coming to a standstill.	

5.6.2 Overview of the machine data for the SE function

Overview of MD for 840D

Table 5-34 Overview of machine data for 840D

Number	Identifier
36901	\$MA_SAFE_FUNCTION_ENABLE
36934	\$MA_SAFE_POS_LIMIT_PLUS[n]
36935	\$MA_SAFE_POS_LIMIT_MINUS[n]
36962	\$MA_SAFE_POS_STOP_MODE
36973	\$MA_SAFE_POS_SELECT_INPUT
Note: Data is described in Chapter 6.1, "Machine data for SINUMERIK 840D"	

Overview of MD for 611digital

Table 5-35 Overview of machine data for 611digital

Number	Identifier
1301	\$MD_SAFE_FUNCTION_ENABLE
1334	\$MD_SAFE_POS_LIMIT_PLUS[n]
1335	\$MD_SAFE_POS_LIMIT_MINUS[n]
1362	\$MD_SAFE_POS_STOP_MODE
Note: Data is described in Chapter 6.2, "Machine data for SIMODRIVE 611digital"	

5.7 Safe software cams (SN)

Description

The "safe software cams" function (SN) can be used to implement safe electronic cams, safe range detection or limiting the working zone/protective zone for specific axes, thereby replacing the hardware solution.

There are 4 pairs of cams (SN1, SN2, SN3, SN4) available for each axis. Each cam pair consists of a plus cam (SN1+, SN2+, SN3+, SN4+) and a minus cam (SN1-, SN2-, SN3-, SN4-). Each cam signal can be individually enabled and configured via machine data. The cam signals are output via SGAs.



Important

The enabled cam signals are immediately output when the control system is powered-up, but are only safe after safe referencing (this is signaled using the SGA "Axis safely referenced").

For safe evaluation of the cam signals, the SGA "Axis safely reference" must be taken into account.

Features

The most important features include:

- Cam positions are safely defined and evaluated as a software function
- Working ranges/zones are defined

Prerequisites

The following prerequisites must be fulfilled for the "safe software cams" function:

The axis/axes must have been safely referenced (user agreement)

- The safe cams must be configured:

The required cams are enabled using MD
\$MA_SAFE_FUNCTION_ENABLE, bits 8...15

The cam positions are defined using MD
\$MA_SAFE_CAM_POS_PLUS[n] and
\$MA_SAFE_CAM_POS_MINUS[n]

SGA assignment is defined using MD
\$MA_SAFE_CAM_PLUS_OUTPUT[n] and
\$MA_SAFE_CAM_MINUS_OUTPUT[n]

5.7 Safe software cams (SN)

Defining the cam positions

The cam positions for SN1+, SN2+, SN3+, SN4+ and SN1-, SN2-, SN3-, SN4- are specified in the following machine data:

For 840D:

MD 36936: \$MA_SAFE_CAM_POS_PLUS[n]

MD 36937: \$MA_SAFE_CAM_POS_MINUS[n]

For 611digital:

MD 1336: \$MD_SAFE_CAM_POS_PLUS[n]

MD 1337: \$MD_SAFE_CAM_POS_MINUS[n]

Tolerance for SN

Owing to variations in the clock cycle and signal run times (signal propagation times), the cam signals of the two monitoring channels do not switch simultaneously and not precisely at the same position. A tolerance bandwidth can therefore be specified for all cams using the following machine data. Within this bandwidth, the signal states for the same cam may be different in the two monitoring channels.

For 840D:

MD 36940: \$MA_SAFE_CAM_TOL

For 611digital:

MD 1340: \$MD_SAFE_CAM_TOL

Note

The lowest possible tolerance bandwidth (less than 5–10 mm) should be selected for the "safe software cams" function.

Special case for SN

If the axis is positioned precisely at the parameterized cam position, the cam signals may have different states owing to system-related variations in the actual values between the two monitoring channels.

This must be taken into account when safely processing the cam signals, e.g. by filtering the different signal states by means of a logic circuit (refer to "Synchronizing cam signals").

Synchronizing cam signals

When cam signal synchronization is activated, the cam results calculated by one monitoring channel are AND'ed with the cam results of the other monitoring channel before they are output.

This means that the cam signals in both channels have the same signal status at standstill (after a transition period resulting from different run times).

Cam signal synchronization is enabled using the following machine data:

For 840D:

MD 36901: \$MA_SAFE_FUNCTION_ENABLE, bit 7

For 611digital:

MD 1301: \$MD_SAFE_FUNCTION_ENABLE, bit 7

Hysteresis of cam SGAs

When cam synchronization is activated, cam signals are output with a hysteresis that takes into account the approach direction (refer to Fig. 5-18, "Hysteresis of the cam SGAs"). This helps prevent the SGAs from "flickering" if the axis is positioned precisely at the cam.

The magnitude of the hysteresis is determined by the following data:

For 840D:

MD 36940: \$MA_SAFE_CAM_TOL
(tolerance for safe software cams)

For 611digital:

MD 1340: \$MD_SAFE_CAM_TOL
(tolerance for safe software cams)

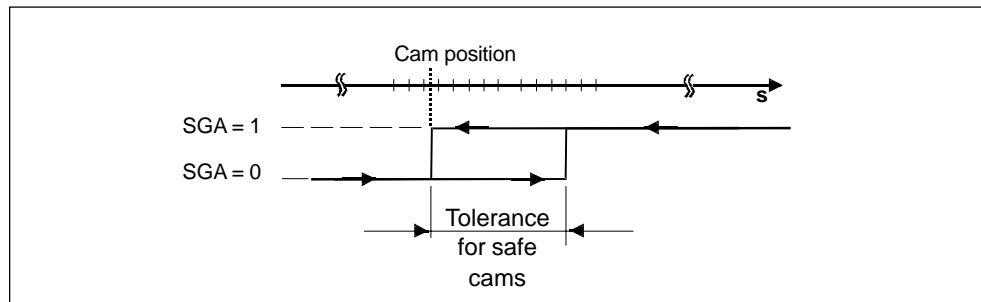

Fig. 5-18 Hysteresis of cam SGAs

Note

Dynamic deviations in the cam signals at I/O devices themselves still occur as a result of the different signal run times between the NCK and PLC I/O devices. These deviations must be taken into account.

5.7 Safe software cams (SN)

Output assignment for SN

The status of the individual cams is indicated using the SGAs SN1+, SN2+, SN3+, SN4+ and SN1-, SN2-, SN3-, SN4-.

For the **NCK monitoring channel**, the NCK-SGAs are assigned to output terminals using the following machine data.

For 840D:

MD 36988: \$MA_SAFE_CAM_PLUS_OUTPUT[n]

MD 36989: \$MA_SAFE_CAM_MINUS_OUTPUT[n]

For the **drive monitoring channel**, the PLC-SGAs are mapped in the NC/PLC interface (refer to Chapter 6.4, "Interface signals") and output from the PLC user program via the PLC I/O.

Modulo display of safe actual values

For rotary axes, the modulo display of safe actual values is selected and parameterized using the following machine data:

MD 30300: \$MA_IS_ROT_AX

MD 30320: \$MA_DISPLAY_IS_MODULO

MD 30330: \$MA_MODULO_RANGE

Safe software cams for endlessly turning rotary axes

For rotary axes with cams, the modulo range (cam actual value range) can be set using the following machine data:

MD 36902/1302: \$MA_/\$MD_SAFE_IS_ROT_AX

MD 36905/1305: \$MA_/\$MD_SAFE_MODULO_RANGE

The cam actual value range should be selected as wide as the modulo display of the safe actual value.

Note

Restrictions relating to cam positions

When cam positions are parameterized, the following conditions must be observed close to the modulo limits:

- When cam synchronization is not active:
 - Lower modulo value
 - $+POS_TOL \leq \text{Cam position}$
 - Upper modulo value
 - $-POS_TOL > \text{Cam position}$
- When cam synchronization is active:
 - Lower modulo value
 - $+POS_TOL \leq \text{Cam position}$
 - Upper modulo value
 - $-POS_TOL - CAM_TOL > \text{Cam position}$

Meanings:

POS_TOL:

Actual value tolerance

(for 840D: MD 36942: \$MA_/\$MD_SAFE_POS_TOL

For 611digital: MD 1342: \$MA_/\$MD_SAFE_POS_TOL)

CAM_TOL:

Cam tolerance

(for 840D: MD 36940: \$MA_/\$MD_SAFE_CAM_TOL

For 611digital: MD 1340: \$MA_/\$MD_SAFE_CAM_TOL)

Lower/upper modulo value:

MD 36905/1305: \$MA_/\$MD_SAFE_MODULO_RANGE

Cam position:

MD 36936/1336: \$MA_/\$MD_SAFE_CAM_POS_PLUS[n]

MD 36937/1337: \$MA_/\$MD_SAFE_CAM_POS_MINUS[n]

When running-up, the parameterization (parameter assignments) are checked in each monitoring channel. In the case of parameterization errors (a condition is not fulfilled), a corresponding alarm is output after the control has run-up.

5.7.1 Effects when SN responds



Important

The machinery construction OEM must safely and logically combine the SGAs SN1-, SN1+ to SN4-, SN4+ that are output via the NCK and PLC I/O devices in accordance with the Safety Integrated principle, i.e. through two channels.

If a response to the cam signals is required, then the machinery construction OEM must implement this function by processing the SGAs. SGAs must be processing redundantly, i.e. in the NCK monitoring channel and the drive monitoring channel (PLC).

When defining cam positions, please note that the function only monitors the actual position thus making (predictive) sensing of cam signals impossible.

Timing when the cam position is passed

If the safe cam function is active, the system timing is as follows when the cam position is passed:

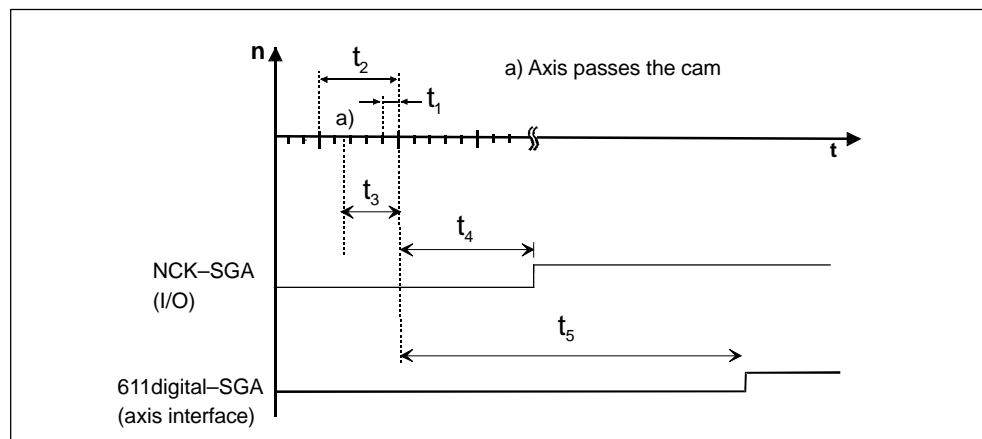

Fig. 5-19 Timing when the cam position is passed

Table 5-36 Explanation of the diagram

Time	Explanation
t_1	The position control clock cycle, defined by the following MDs: For 840D: MD 10050: \$MN_SYSCLOCK_CYCLE_TIME MD 10060: \$MN_POSCTRL_SYSCLOCK_TIME_RATIO
t_2	Monitoring clock cycle, defined by the following MDs: For 840D: MD 10090: \$MN_SAFETY_SYSCLOCK_TIME_RATIO For 611digital: MD1300: \$MD_SAFETY_CYCLE_TIME

Table 5-36 Explanation of the diagram

Time	Explanation
t_3	Time until it has been detected that the cam position has been passed (maximum 1 monitoring clock cycle)
t_4	Conditioning time for the NCK monitoring channel Without SPL: 1 SI monitoring clock cycle plus a few microseconds With SPL: 1SI monitoring clock cycle plus 1IPO clock cycle The following apply Without SPL: Delay up to the DMP module terminal With SPL: Delay up to the SPL interface
t_5	Processing time, 611 digital monitoring channel (delay time up to the user interface (DB3x)) Maximum 1 SI monitoring plus 2 IPO clock cycles plus 1 OB1 clock cycle Minimum 1 SI monitoring plus 2 IPO clock cycles
Note: Each axis must be measured during commissioning (start-up) to determine how long it takes for cam signals to be output to the I/O after the cam position has been passed.	

5.7.2 Application example for "safe software cams"

Task

The axis speed must be monitored for violation of various speed limit values based on position ranges 1, 2 and 3 of an axis. This means that if the axis is in range 1, 2, 3 then its speed must be monitored for violation of speed limit value 1, 3, 4.

The position ranges are defined using cam signals SN1- and SN1+.

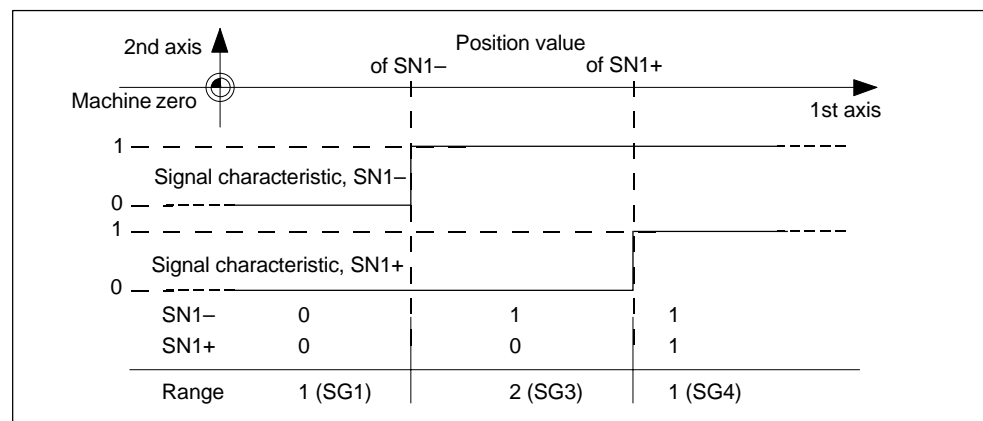

Fig. 5-20 Signal characteristics, positioning and ranges

5.7 Safe software cams (SN)

Note

For this example, cam synchronization must be enabled using the following machine data:

For 840D:

MD 36901, bit 7: \$MA_SAFE_FUNCTION_ENABLE

For 611digital:

MD 1301, bit 7: \$MD_SAFE_FUNCTION_ENABLE

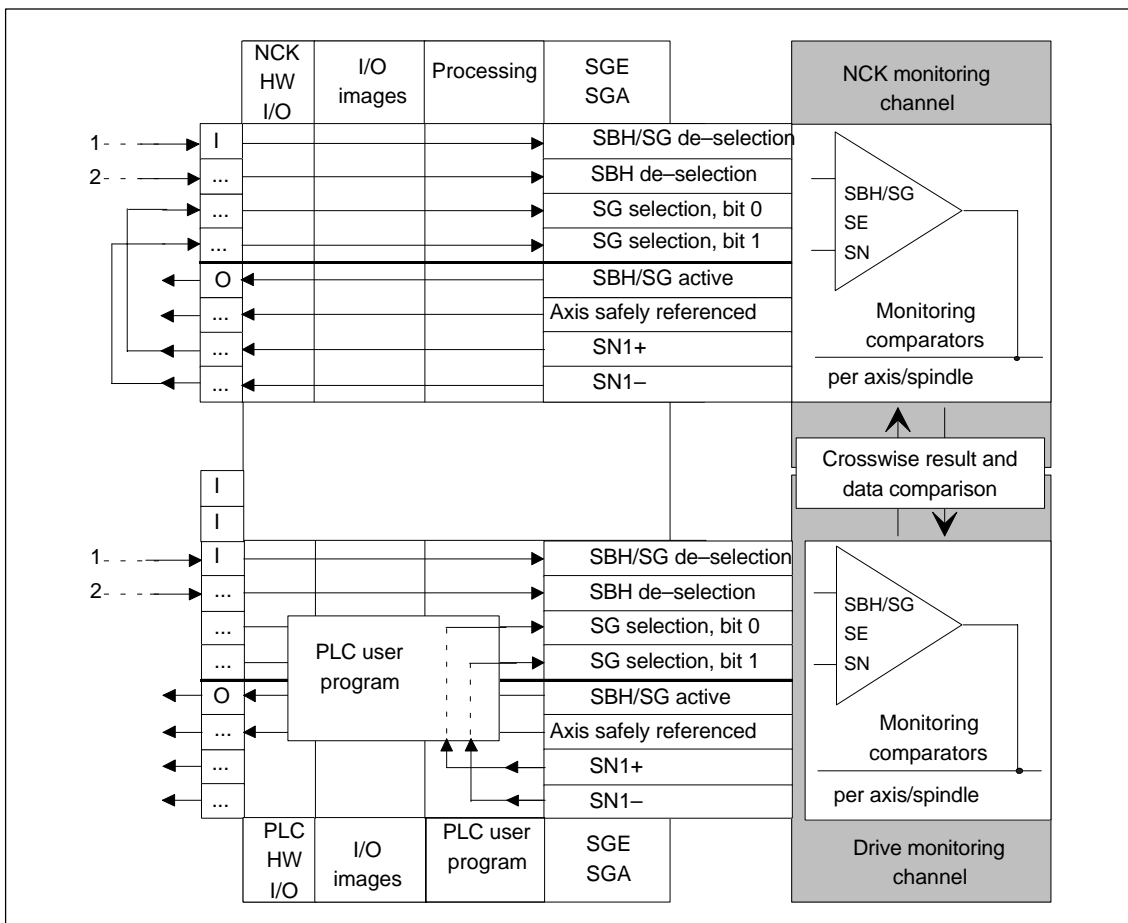

Fig. 5-21 Connecting the required SGEs/SGAs (without SPL)

Assumptions for the example

The example is applicable for the 1st axis

Position values: SN1- = 300 mm, SN1+ = 600 mm

Speed limit values:

Range 1 = 1000 mm/min

Range 2 = 2000 mm/min

Range 3 = 4000 mm/min

Defining the SGEs/SGAs in the NCK monitoring channel

for 840D

Logical slot for the terminal block:	9
Slot number of the sub-module for SGEs:	1
Slot number of the sub-module for SGAs:	2
I/O number for signal SN1+:	7
I/O number for signal SN1-:	6
I/O number for signal, axis safely referenced:	5
I/O number for signal SBH/SG active:	4
I/O number for signal SBH/SG de-selection:	2
I/O number for signal SBH de-selection:	3
I/O number for signal, SG selection, bit 1:	6
I/O number for signal, SG selection, bit 0:	7

If the axis is positioned precisely at the parameterized cam position, the cam signals may have different states owing to variations in the actual values between the two monitoring channels. If the SGAs "SNx" are directly connected to the SGEs "SG selection" a crosswise data comparison would in this case signal an error. When cam synchronization is activated, in the steady-state condition, the cam signals are output with the same signal states in both channels.

Note

Machine data for the safely-reduced speed function are described in Chapter 4.

5.7 Safe software cams (SN)

Defining machine data

Table 5-37 Supplying MD for cam positions

	for 840D		for 611digital	
	MD No.	Value	MD No.	Value
SN1-	36937	300	1337[0]	300 000
SN1+	36936	600	1336[0]	600 000

Table 5-38 Supplying MD for speed limit values

Limit value	for 840D		for 611digital	
	MD No.	Value	MD No.	Value
1	36931[0]	1000	1331[0]	1000
2	36931[1]	0	1331[1]	0
3	36931[2]	2000	1331[2]	2000
4	36931[3]	4000	1331[3]	4000

Table 5-39 Assigning speed limit values to the ranges

Speed limit value	SG selection		Range	Comment
	Bit 1	Bit 0		
	1	0		
2	0	1	-	Not used
3	1	0	2	SG3 active
4	1	1	3	SG4 active

Table 5-40 Supplying MD for the SGEs/SGAs for 840D

Signal		Assignment	
SGE/SGA	Name	MD No.	Value
SGA	SN1+	36988[0]	01 09 02 07
SGA	SN1-	36989[0]	01 09 02 06
SGA	Axis safely referenced	36987	01 09 02 05
SGA	SBH/SG active	36980	01 09 02 04
SGE	SBH/SG de-selection	36970	01 09 01 02
SGE	SBH de-selection	36971	01 09 01 03

Table 5-40 Supplying MD for the SGEs/SGAs for 840D

SGE/SGA	Name	MD No.	Value
SGE	SG selection, bit 1	36972[1]	01 09 01 06
SGE	SG selection, bit 0	36972[0]	01 09 01 07

Note

The appropriate signals should be accordingly processed by the PLC in the drive monitoring channel (refer to Chapter 5.9.2, "Signal processing for the drive monitoring channel").

In order to ensure safe evaluation of the cam signals, the SGA "axis safely referenced" must be taken into account.

The SGA "axis safely referenced" can be logically combined with the SGA "SBH/SG active" if the signal is used to enable a protective zone (refer to Chapter 7, "Engineering example").

Advantage:

Machine data can be used to implement an AND logic operation in the NCK monitoring channel (refer to Chapter 6.1, "Machine data for SINUMERIK 840D").

5.7.3 Overview of machine data for the SN function

Overview of MD for 840D

Table 5-41 Overview of machine data for 840D

Number	Identifier
36901	\$MA_SAFE_FUNCTION_ENABLE
36905	\$MA_SAFE_MODULO_RANGE
36936	\$MA_SAFE_CAM_POS_PLUS[n]
36937	\$MA_SAFE_CAM_POS_MINUS[n]
36940	\$MA_SAFE_CAM_TOL
36988	\$MA_SAFE_CAM_PLUS_OUTPUT[n]
36989	\$MA_SAFE_CAM_MINUS_OUTPUT[n]
Note: Data is described in Chapter 6.1, "Machine data for SINUMERIK 840D"	

Overview of MD for 611digital

Table 5-42 Overview of machine data for 611digital

Number	Identifier
1301	\$MD_SAFE_FUNCTION_ENABLE
1305	\$MD_SAFE_MODULO_RANGE
1336	\$MD_SAFE_CAM_POS_PLUS[n]
1337	\$MD_SAFE_CAM_POS_MINUS[n]
1340	\$MD_SAFE_CAM_TOL
Note: Data is described in Chapter 6.2, "Machine data for SIMODRIVE 611digital"	

5.8 Safe braking ramp (SBR)

Description

This function is based on the assumption that after a stop request, the actual speed must decrease (the speed characteristic is monitored).

Note

Regarding 840D/611digital:

The function exists in both monitoring channels and must also be parameterized in both channels.

Features

The most important features include:

- Fastest possible detection if the axis starts to re-accelerate when braking
- SBR is automatically activated, when a STOP B or C has been triggered
- STOP A is triggered when SBR responds

Activating the SBR

When a stop request is triggered, the actual speed plus the speed tolerance, defined in the machine data, is activated as the speed limit. This limit is compared with the actual speed (must decrease or remain the same) and is cyclically corrected. If the axis starts to re-accelerate while braking, this is detected as quickly as possible.

Machine data for the SBR speed tolerance:

For 840D:

MD 36948: \$MA_SAFE_STOP_VELO_TOL

For 611digital:

MD 1348: \$MD_SAFE_STOP_VELO_TOL

The speed limit is corrected until the speed, defined in the following machine data, is undershot (fallen below). After that, the limit value of the SBR monitoring is frozen to the value in MD 36946/1346 plus the value in MD 36948/1348.

For 840D:

MD 36946: \$MA_SAFE_VELO_X (speed limit n_x)

5.8 Safe braking ramp (SBR)

For 611digital:

MD 1346: \$MD_SAFE_VELO_X

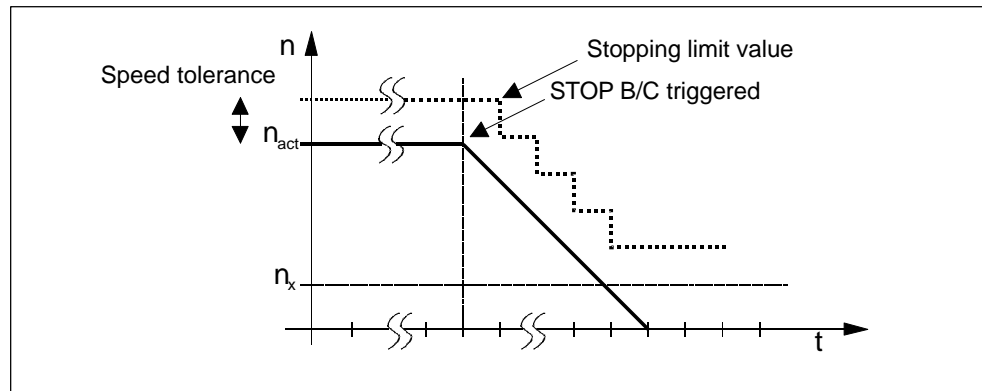

Fig. 5-22 Characteristics of the stopping limit value for SBR

Calculating the SBR tolerance of the actual speed

The following applies when parameterizing the SBR tolerance:

The possible speed increase after initiating a STOP B/C is obtained from the effective acceleration a and the duration of the acceleration phase. The acceleration phase lasts from one monitoring clock cycle $\ddot{U}T$ (delay from detecting a STOP B/C until $n_{\text{set}} = 0$):

SBR tolerance

Actual speed for SBR = acceleration * acceleration duration

The following setting rules apply:

For a linear axis:

SBR tolerance [mm/min] = a [m/s²] * $\ddot{U}T$ [s] * 1000 [mm/m] * 60 [s/min]

For rotary axis/spindle:

SBR tolerance [rev/min] = a [rev/s²] * $\ddot{U}T$ [s] * 60 [s/min]

The following machine data should be taken into account when determining the acceleration:

MD 32300: MAX_AX_ACCEL

MD 35200: GEAR_STEP_SPEEDCTRL_ACCEL

MD 35210: GEAR_STEP_POSCTRL_ACCEL

MD 35410: SPIND_OSCILL_ACCEL

Recommendation:

The value entered for the SBR tolerance should be approx. 20% higher than the calculated value.

**Caution**

During "normal" operation, speed overshoot should not unintentionally trigger the SBR. Speed overshoot should therefore be checked by making the appropriate measurements.

**Warning**

If the "safe standstill" function or "STOP A" is activated, the motor can no longer generate any torque. This is the reason that potentially hazardous motion can occur, e.g. for the following:

- When an external force acts on the drive axes
- Vertical and inclined axes without weight equalization
- Axes that are moving (coasting down)
- Direct drives with low friction and low self-locking
- Notching torques (depending on the motor type, bearing design and friction characteristics, up to half a pole pitch in a direction that cannot be predicted).

Possible hazards must be clearly identified using a risk analysis that must be carried-out by the manufacturer. With an assessment, based on this risk analysis, it should be defined as to which additional measures are required, e.g. external brakes.

5.8.1 Overview of machine data for SBR

Overview of MD for 840D

Table 5-43 Overview of machine data for 840D

Number	Identifier
36948	\$MA_SAFE_STOP_VELO_TOL
32300	\$MA_MA_AX_ACCEL
35200	\$MA_GEAR_STEP_SPEEDCTRL_ACCEL
35210	\$MA_STEP_POSCTRL_ACCEL
35410	\$MA_SPIND_OSCILL_ACCEL
Note: Data is described in Chapter 6.1, "Machine data for SINUMERIK 840D"	

Overview of MD for 611digital

Table 5-44 Overview of machine data for 611digital

Number	Identifier
1348	\$MD_SAFE_STOP_VELO_TOL
Note: Data is described in Chapter 6.2, "Machine data for SIMODRIVE 611digital"	

5.9 Safety-related input/output signals (SGE/SGA)

Description

The safety-related input and output signals (SGEs and SGAs) are the interface of the internal Safety Integrated functionality to the process. Both monitoring channels have, for each axis or drive, their own interface for safety-related input and output signals. They are supplied and/or processed through different paths.

SGE signals (safety-related input signals) control the active monitoring by de-selecting or selecting the safety functions. This is realized, among other things, depending on the status (switching status) of sensors and transmitters.

SGA signals (safety-related output signals) are feedback signals from safety functions. They are, among other things, suitable for controlling actuators in a safety-related fashion.

It is not absolutely necessary that SGE/SGA are routed using hardware terminals. Depending on the requirement, in conjunction with SPL (refer to Chapter 5.10, pure internal processing is also possible as software signal.

For Safety Integrated, sensors/actuators can be connected in various ways:

- Through separate NCK and PLC I/O

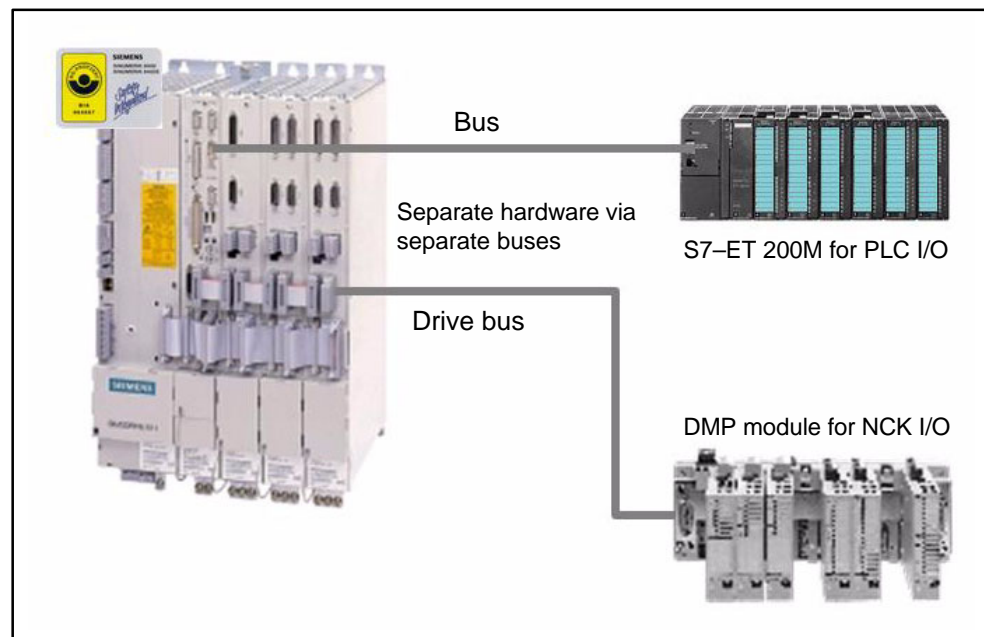

Fig. 5-23 Connecting sensors/actuators via separate PLC and NCK I/O

- or using PROFIBUS with the PROFIsafe profile and S7 fail-safe modules/boards

5.9 Safety-related input/output signals (SGE/SGA)

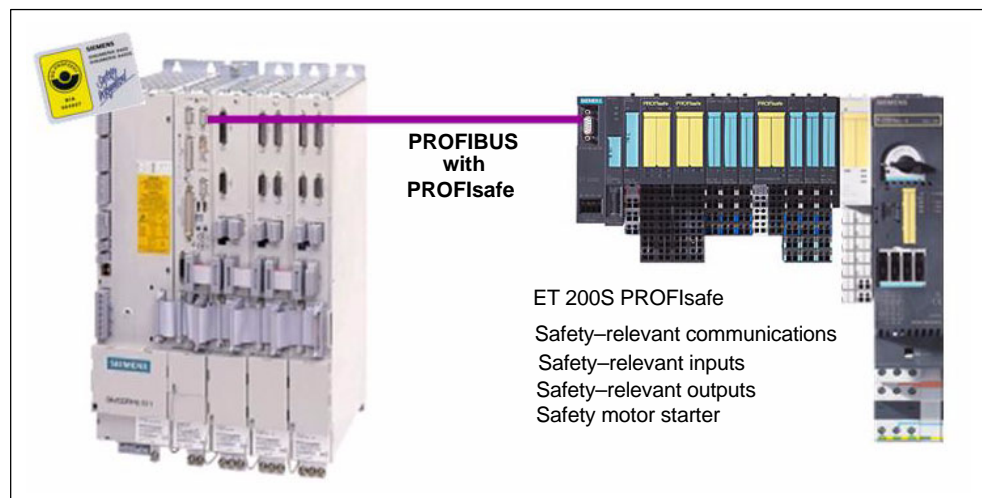

Fig. 5-24 SGE/SGA via PROFIBUS with the PROFIsafe protocol

When sensors/actuators are connected through separate NCK and PLC I/O, SGE/SGA signals can be directly accessed using hardware or via SPL.

When sensors/actuators are connected using PROFIBUS with the PROFIsafe protocol, SGE/SGA signals can only be accessed via SPL (refer to Chapter 5.11).

The following can be requested or signaled in each monitoring channel and for each/spindle with safety technology using SGE/SGA signals:

- Safety functions can be selected and de-selected
- Speed limit values can be selected and changed-over
- Position limit values can be selected and changed-over
- Status messages relating to safety operation can be fed back
- Cam signals can be output

Features

- SGE and SGA signals are processed through two channels
- Processed in the NCK monitoring channel
- Processed in the drive monitoring channel
- Safety functions are selected/de-selected independent of the NC mode
- Differences in the active SGEs in the monitoring channels are detected in the crosswise data/result comparison

The processing and the basic principle for processing SGE/SGA signals based on a solution with SPL and connecting sensors/actuators through separate NCK and PLC I/O are described in the following.

The statements made for the SGE and SGA signals also apply in conjunction with SPL and other sensor/actuator connections. The only thing that changes is the way in which SGE/SGA signals are accessed. The changes are described in Chapter 5.10 "Safe programmable logic (SPL)" and Chapter 5.11 "SI I/O using fail-safe motors on PROFIBUS-DP".

Note

The state of a deleted SGE/SGA (logical "0") that can be achieved both by the user as well as also using fault responses of the "SINUMERIK Safety Integrated" system, are defined as so-called "fail-safe state" of an SGE/SGA. This is the reason that a system is only suitable for applications where this state corresponds to the fail-safe state of the process controlled by "SINUMERIK Safety Integrated".

Processing I/O signals for the NC and drive through two channels

A two-channel structure is used to input/output and process safety-related input/output signals (refer to Fig. 5-25 "NCK and drive monitoring channel"). All of the requests and feedback signals for safety-related functions should be entered or retrieved through both monitoring channels (two-channel structure).

5.9 Safety-related input/output signals (SGE/SGA)

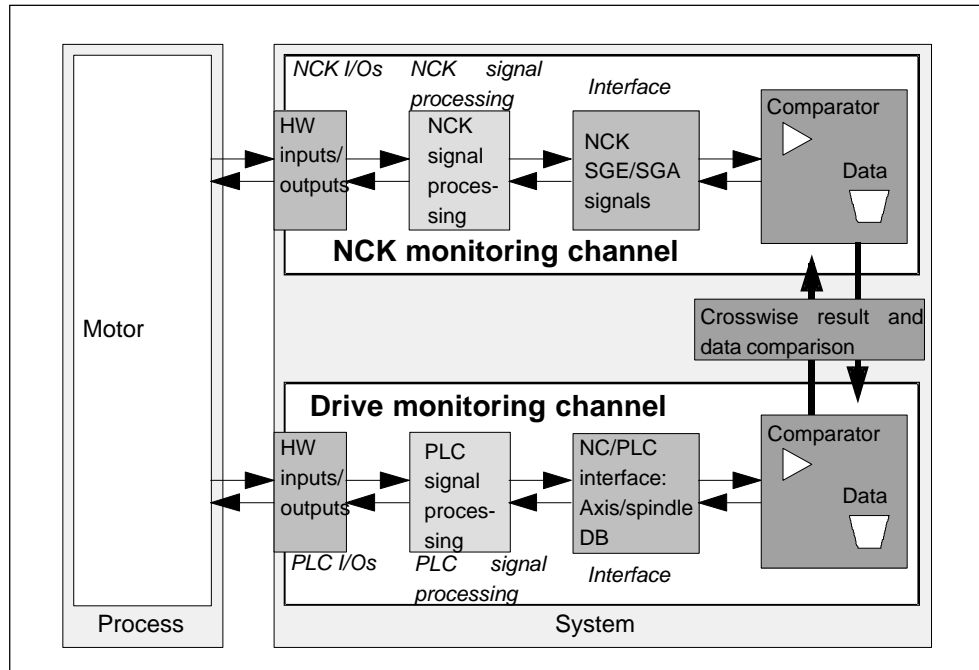

Fig. 5-25 NCK and drive monitoring channel

For the NCK monitoring channel, signals are input/output via the NCK I/O. They are processed by the NCK interlocking block and emulated (mapped) in the NCK-SGE/SGA interface.

The signals from the drive monitoring channel are input/output via the PLC I/O, processed by the PLC user program and communicated/signaled to the drive or PLC via the NC/PLC interface.

5.9 Safety-related input/output signals (SGE/SGA)

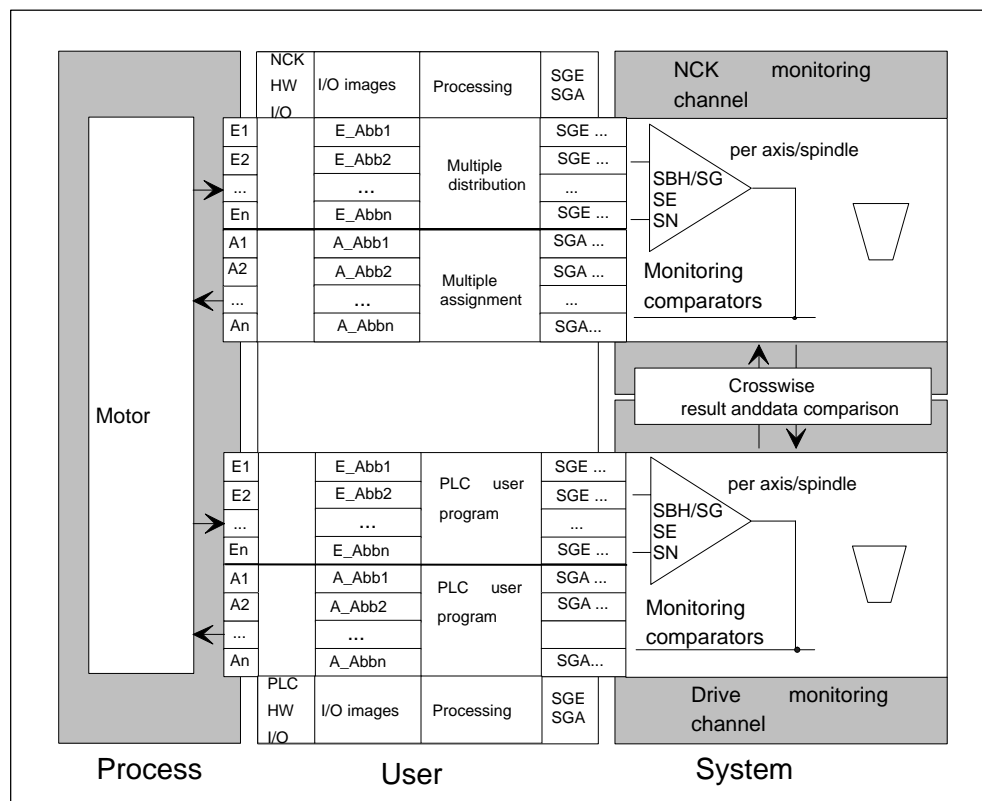

Fig. 5-26 I/O signal processing through two channels

Crosswise data comparison is implemented between the monitoring channels that operate independently of one another. STOP F is triggered if this crosswise data comparison detects a difference.

Note

As a result of the two-channel structure – both in the **NCK monitoring channel** as well as in the **drive monitoring channel** – **SGEs** and **SGAs** must be **supplied** from the machinery construction OEM.

The actual signal state of the SGEs/SGAs is selected using the "Service display" menu. Information regarding Safety Integrated data with the associated axis names and the axis number are displayed in the "Service SI" window.

Basic principle for safety-related signal processing

For a two-channel control, it is only necessary to have a single-channel feedback through the PLC.

However, on the other hand, for a single-channel control, the feedback must be configured redundantly – i.e. using a two-channel feedback.

5.9 Safety-related input/output signals (SGE/SGA)

Which SGEs/SGAs are there?

For each axis/spindle, the following SGEs and SGAs are in each monitoring channel:

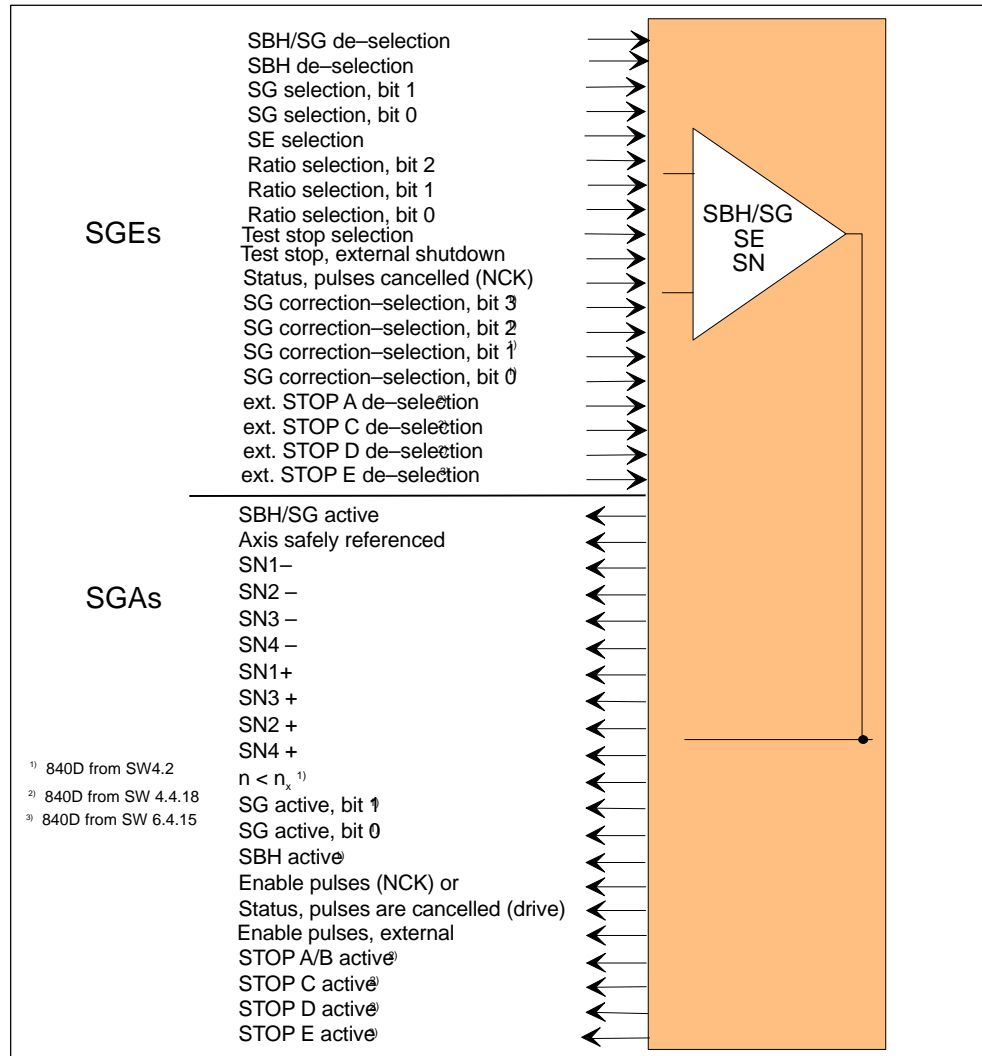

Fig. 5-27 SGEs and SGAs in every monitoring channel for each axis/spindle

Note

The SGE/SGA signals are described in Chapter 6.4, "Description of Interface signals".

How many SGEs/SGAs are required as a minimum?

Depending on the particular application, only some of the maximum number of SGEs/SGAs available are required.

Note

SGEs that are not required should be set to a defined signal state.

In the NCK monitoring channel:

By appropriately pre-assigning the associated machine data (e.g. assign the input permanently to 0 (standard) or 1)

In the drive monitoring channel:

By appropriately programming the interface signals in the PLC user program

Table 5-45 Minimum SGEs/SGAs required

Function	Minimum SGEs required	Minimum SGAs required
Safe operating stop (SBH)	SBH/SG de-selection Test stop selection Status, pulses cancelled (NCK)	SBH/SG active Enable pulses (NCK) Status, pulses cancelled (drive)
Safely-reduced speed (SG)	SBH/SG de-selection SBH de-selection SG selection, bit 1 (only for SG changeover) SG selection, bit 0 (only for SG changeover) Gear ratio selection, bit 2 (only to select the gear ratio) Gear ratio selection, bit 1 (only to select the gear ratio) Gear ratio selection, bit 0 (only to select the gear ratio) Test stop selection Status, pulses cancelled (NCK)	SBH/SG active Enable pulses (NCK) Status, pulses cancelled (drive)
Safe software limit switches (SE)	SE selection (only for SE changeover) Test stop selection Status, pulses cancelled (NCK) SBH/SG de-selection (at least for test during commissioning [start-up])	Axis safely referenced Enable pulses (NCK) or Status, pulses cancelled (drive)
Safe software cams (SN)	Test stop selection Status, pulses cancelled (NCK) SBH/SG de-selection (at least for test during commissioning [start-up])	Axis safely referenced SN1 -, SN2 -, SN3 -, SN4 - (only where required) SN1+, SN2+, SN3+, SN4+ (only where required) Enable pulses (NCK) or Status, pulses cancelled (drive)

5.9 Safety-related input/output signals (SGE/SGA)

Different signal run times in the channels

The signal timing in the two monitoring channels varies (the PLC cycle time takes up most of the available time in the drive monitoring channel). To prevent the crosswise data comparison function from being immediately activated after a signal change, a tolerance time is defined using the following machine data.

For 840D:

MD 36950: \$MA_SAFE_MODE_SWITCH_TIME

For 611digital:

MD 1350: \$MD_SAFE_MODE_SWITCH_TIME

This data specifies the time period for which different signal states may be tolerated after the SGEs have been changed-over before an error message is output.

Note

System-related minimum tolerance time
2 x PLC cycle time (maximum cycle) + 1 x IPO cycle time

The variations in the run times in the external circuitry (e.g. relay operating times) must also be taken into account.

NCK SGEs/SGAs

There are SGEs and SGAs for each axis/spindle (refer to Fig. 5-27 "SGEs and SGAs in each monitoring channel for each axis/spindle").

The signals are assigned to the NCK inputs and outputs using machine data. Only the NCK-SGEs are assigned to an NCK input that are also required for the particular application.

For axes, where for example, the gear ratio does not change, then NCK-SGs "ratio selection bit 2 to 0" do not have to be assigned to hardware inputs. A value of 0 should be entered into the associated MD (i.e. the NCK-SGE does not have a hardware assignment and is set to 0).

PLC SGEs/SGAs

For the drive monitoring channel, the NC/PLC interface (axis/spindle DB) represents the SGE/SGA interface between the PLC and the drive. The PLC user program must supply this interface. The standard PLC I/O should be used to input/output signals to/from the machine.

In the PLC user program, the machinery construction OEM defines whether the SGE/SGAs are processed using the PLC I/O or whether they are generated and evaluated internally in the software.

Note

Only the PLC-SGEs should be processed in the PLC user program that are also required for the particular application. SGEs that are not used must be set to the value 0 – i.e. to a defined state. This does not apply to external STOPS that are not used (refer to Chapter 3.2).

Refer to Chapter 3.2.2 for information about SGEs/SGAs for the test stop for external stops.

5.9.1 Signal processing for the NCK monitoring channel

Note

The SGEs/SGAs must be supplied by the machine manufacturer – both in the NCK monitoring channel and in the drive monitoring channel.

Digital NCK inputs/outputs for 840D

The number of inputs and outputs that can be connected increases when the SI safety function is used

- Up to 64 digital inputs and outputs for the function "safe programmable logic" SPL
- By additional digital inputs and outputs for safety axes. Further information:

Reference: /FB/, A4, Digital and Analog NCK I/O
/HDB/, NCU Manual, SINUMERIK 840D

Please note the following with regard to implementing the NCK I/O:

- 2 NCU terminal blocks and DMP compact modules are used for the NCK I/O.
- In comparison to "normal" NCK inputs/outputs (refer to Reference: /FB/, A4, Digital and Analog NCK I/O) other, additional NCK inputs/outputs are used for Safety Integrated.
- The "normal" NCK inputs and those for Safety Integrated may also be used for both purposes (double assignment). An appropriate alarm is generated for NCK outputs that are assigned twice.

5.9 Safety-related input/output signals (SGE/SGA)

Note

The digital outputs are reserved byte-serially for SGAs. If at least 1 output is used for an SGA, then the remaining outputs of this particular byte may not be used for other functions.

The machinery construction OEM is responsible in ensuring that digital NCK outputs are not assigned twice (this would result in a conflict) by configuring them correctly.

For SINUMERIK 840D, the number of NCK SGEs/SGAs is only limited by the maximum available number of NCK I/O hardware devices that can be inserted.

Processing NCK-SGEs for 840D (multiple distribution)

Axis-specific/spindle-specific machine data is used to define which input is to be used for which function and which axis/spindle. Under the condition that certain axes/spindles belong to the same safety group, it is possible to implement multiple distribution (1 input is assigned, for example, to 3 axes with the same function). In addition, when an NCK input is selected via MD, it is also possible to define whether the inverted signal is also to be processed.

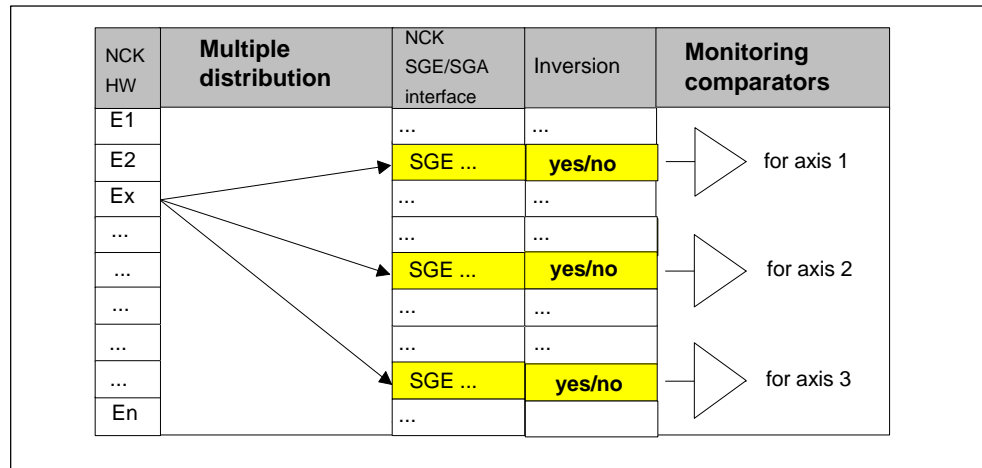

Fig. 5-28 Multiple distribution of NCK inputs

Example

It must be possible to change over between the "safe software limit switches" 1 or 2 for axes 1, 2 and 3 as a group using an NCK input "x".

The machine data must be parameterized as follows:

Axis 1: MD 36973: \$MA_SAFE_POS_SELECT_INPUT = input x

Axis 2: MD 36973: \$MA_SAFE_POS_SELECT_INPUT = input x

Axis 3: MD 36973: \$MA_SAFE_POS_SELECT_INPUT = input x

(input x = ss mm xx nn, refer to Chapter 6.1, "Machine data for SINUMERIK 840D")

Processing NCK-SGAs for 840D (multiple assignment)

Axis-specific/spindle-specific machine data is used to define which SGA from which axis/spindle must be assigned to which NCK output. It is possible to implement a multiple assignment (SGAs from several axes are assigned to 1 output) provided that certain axes/spindles belong to the same safety group. The SGAs are then ANDed and the result output at the NCK output. In addition, when an NCK output is selected via an MD, it is also possible to define whether the signal is to be output in an inverted form before it is ANDed.

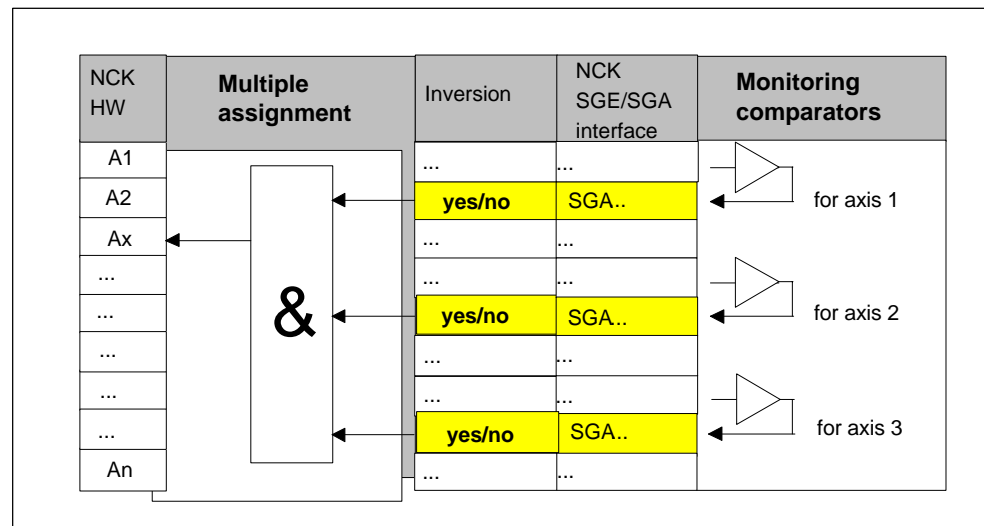

Fig. 5-29 Multiple assignment for NCK outputs

5.9 Safety-related input/output signals (SGE/SGA)

Example

Axes 1, 2 and 3 belong to one safety area. For these axes, the message "axis safely referenced" should be output at one NCK output (this means that the message is output if the message (signal) is present for all 3 axes).

The machine data must be parameterized as follows:

Axis 1: MD 36987: \$MA_SAFE_REFP_STATUS_OUTPUT = output x
 Axis 2: MD 36987: \$MA_SAFE_REFP_STATUS_OUTPUT = output x
 Axis 3: MD 36987: \$MA_SAFE_REFP_STATUS_OUTPUT = output x
 (output x = ss mm xx nn, refer to Chapter 6.1, "Machine data for 840D")

5.9.2 Signal processing in the drive monitoring channel

General information

The safety-related input and output signals (SGEs and SGAs) are signals that are sent to and received from the system through two channels:

Via the NCK monitoring channel

←→ NCK I/O devices ←→ signal processing in NCK ←→
 axial SGE/SGA interface ←→ NCK monitoring channel

Via the drive monitoring channel

←→ PLC I/O ←→ signal processing using the PLC ←→
 NC/PLC interface ←→ drive monitoring channel

Note

The SGEs/SGAs must be supplied by the machinery construction OEM – both in the drive monitoring channel as well as in the NCK monitoring channel.

Digital PLC inputs/outputs for 840D

For SINUMERIK 840D, digital PLC inputs and outputs are implemented using the SIMATIC S7-300 I/O devices.

Reference: /S7H/, SIMATIC S7-300

Processing signals for 840D

A PLC module that is compatible with the SIMATIC S7-315-2DP is used as the PLC in the SINUMERIK 840D. Signals are processed according to what has been programmed in the PLC user program (refer to Chapter 6.4 "Interface signals for SINUMERIK 840D").

Reference: /FB/, P3, "PLC Basic Program"

PLC SGE/SGA interface for 840D

The machine state is transferred to the monitoring comparators for specific axes/spindles via PLC inputs and the PLC user program.

The PLC SGE/SGA interface is mapped using the following axis/spindle-specific data blocks:

DB 31... (assignment of the data block
refer to Chapter 6.4 "Interface signals for SINUMERIK 840D")

5.9 Safety-related input/output signals (SGE/SGA)

5.9.3 Overview of machine data for SGE/SGA

Overview of MD for 840D

Table 5-46 Overview of machine data for 840D

Number	Identifier
36950	\$MA_SAFE_MODE_SWITCH_TIME
36970	\$MA_SAFE_SVSS_DISABLE_INPUT
36971	\$MA_SAFE_SS_DISABLE_INPUT
36972	\$MA_SAFE_VELO_SELECT_INPUT[n]
36973	\$MA_SAFE_POS_SELECT_INPUT
36974	\$MA_SAFE_GEAR_SELECT_INPUT[n]
36975	\$MA_SAFE_STOP_REQUEST_INPUT
36976	\$MA_SAFE_PULSE_STATUS_INPUT
36977	\$MA_SAFE_EXT_STOP_INPUT
36978	\$MA_SAFE_OVR_INPUT
36979	\$MA_SAFE_STOP_REQUEST_EXIT_INPUT
36980	\$MA_SAFE_SVSS_STATUS_OUTPUT
36981	\$MA_SAFE_SS_STATUS_OUTPUT
36982	\$MA_SAFE_VELO_STATUS_OUTPUT
36984	\$MA_SAFE_EXT_PULSE_ENABLE_OUTPUT
36985	\$MA_SAFE_VELO_X_STATUS_OUTPUT
36986	\$MA_SAFE_PULSE_ENABLE_OUTPUT
36987	\$MA_SAFE_REFP_STATUS_OUTPUT
36988	\$MA_SAFE_CAM_PLUS_OUTPUT[n]
36989	\$MA_SAFE_CAM_MINUS_OUTPUT[n]
36990	\$MA_SAFE_ACT_STOP_OUTPUT
Note: Data is described in Chapter 6.1, "Machine data for SINUMERIK 840D"	

5.10 Safe programmable logic (SPL)

Function

Up until now, safety-related signals were processed in external logic.

SPL – comprising NCK SPL and PLC SPL, greatly reduces the amount of external wiring required. The logic used up until now has been replaced by a written program (SPL).

Features:

- Logic operations implemented by the user are cyclically processed
- Instructions are effective in all operating modes
- The PLC program immediately starts to execute the instructions after the control has run-up

In order to check that the two SPLs (PLC and NCK) are functioning, the system program arranges cyclic data comparison between the PLC and NCK. The NCK-CPU and the PLC-CPU monitor independently of one another. This involves a crosswise data comparison of the signals that are entered into the SPL and the safety-related signals generated by the SPL as well as internal states (markers).

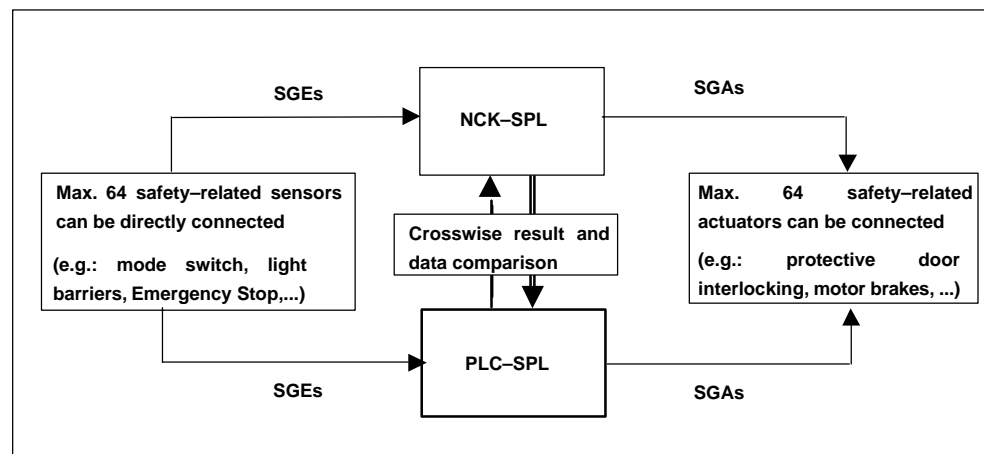

Fig. 5-30 Safe programmable logic

Logic operations

Drive monitoring channel:

Using the appropriate programming in the PLC user program, SGEs/SGAs can be logically combined with one another as required. The result is output at the interface and at the PLC I/O.

5.10 Safe programmable logic (SPL)

NCK monitoring channel:

The SGEs/SGAs are allocated using input and output assignments, that can be parameterized using the appropriate machine data.

The input signals can be processed using multiple distribution (1 input is assigned to several axes) and the output signals by multiple assignment (signals of several axes are assigned to 1 output).

The multiple distribution/assignment can also be parameterized using the appropriate machine data.

Further, signals can be processed in the NCK-SPL program to be created. This program is written as ASUB using the CNC function "synchronous actions". The input/output signals can be logically combined with other signals. The result is output at the internal interface or at the NCK I/O. An SGA can also be fed back internally as SGE (without any external circuitry).

Activating

The NCK-SPL is active after the control has run-up, if at least

1. The functions SBH/SG and "external STOPS" have been selected for at least one axis using \$MA_/\$MD_SAFE_FUNCTION_ENABLE,
2. One of the NCK-SPL interfaces is used.
This means that an axial SGE/SGA has been parameterized at one of the SPL interfaces using its assignment MD or the external SPL interfaces \$A_OUTSE/\$A_INSE have been parameterized using MD \$MN_SAFE_OUT_HW_ASSIGN/\$MN_SAFE_IN_HW_ASSIGN. When PROFIsafe I/Os are used (refer to Chapter 5.11) the MD \$MN_PROFISAFE_IN/OUT_ADDRESS applies.

In this case, the "external STOP A" must be parameterized at the SPL interface for **all** of the axes that use safety integrated.

In addition, the following machine data must be set for an error-free ASUB start after the NCK and the PLC have run-up:

3. \$MN_ASUP_START_MASK=7:
ASUB can be started in all operating states of the NC (RESET/JOG/not all axes referenced/read-in active).
4. \$MN_ASUP_START_PRIO_LEVEL=1:
Interrupt priority, from which MD \$MN_ASUP_START_MASK becomes active.

Other actions to be executed:

5. A PLC-SPL, has to be implemented and integrated into the PLC user program (incl. FB4 and FC9 call of _N_SAFE_SPF; this starts the NCK-SPL)
6. An NCK-SPL has to be created and loaded into the directory /_N_CST_DIR into the file /_N_SAFE_SPF (= MMC view standard cycles/SAFE.SPF)

Note

No alarms may be present when an ASUB starts, e.g. Alarm 3000 Emergency Stop.

Note

The SPL can also be activated via PROG_EVENT mechanism (refer to Chapter 5.10.2).

SPL start without axial safety enable

In order to improve the procedure when commissioning a machine, an SPL can be started without the axial safety function first being enabled.

It is therefore possible to handle general machine functions (hydraulics, EMERGENCY STOP) before the axis is commissioned.

This is only possible in the commissioning state of the SPL (\$MN_PRE-VENT_SYNACT_LOCK[0,1]==0 and DB18.DBX36.0==0).

This state is displayed when the SPL starts using Alarm 27095 "%1 SPL protection not activated".

If an attempt is made to start the SPL in the protective state (after commissioning has been completed) without the axial safety function having been activated, then Alarm 27096 is output. The SPL is started if the SPL crosswise data comparison is not activated.

Crosswise data comparison

Data is cyclically exchanged between the PLC and NCK to check the correct functioning of the two SPLs (PLC and NCK). Just the same as the comparison between the NCK and the drive, it cross-checks the signals that arrive at the SPL, the safety-related signals generated by the SPL as well as internal markers.

The discrepancy time for the crosswise data comparison of SPL variables is permanently set to 1 s (or 10 s \$A_CMDSI).

The following signals are included in the crosswise data comparison between the NCK and the PLC:

\$A_INSE[1 ... 64]

\$A_OUTSE[1 ... 64]

\$A_INSI[1 ... 64]

\$A_OUTSI[1 ... 64]

\$A_MARKERSI[1 ... 64]

5.10 Safe programmable logic (SPL)

Deleting the external SPL outputs for SPL system errors (from SW 6.5.11)

If communications between the NCK and PLC with reference to the SPL crosswise data comparison, are interrupted, then all external SPL output signals (\$A_OUTSE/\$A_OUTSEP) are deleted with a delay of 5 s.

This state occurs if no data exchange or crosswise data comparison occurs between the NCK and PLC for one second. This is due to the fact that

- the 1 second limit of the user cycle limit in the PLC (OB1 cycle) was exceeded.
- a system error has occurred. The NCK or PLC system software no longer runs due to a system error – therefore interrupting communications.

Behavior of the NCK

The specified timer of 5 s is started if Alarm 27092 "Communication interrupted for crosswise data comparison NCK-SPL, error detected by %1" is initiated. This is independent of which component (NCK or PLC) interrupted the alarm.

The system variable \$A_STATSID, bit 29 = 1 is used to indicate to the SPL user that this timer has been started. This means that he has a possibility of initiating plant/system-specific actions before the system deletes (clears) the output.

After this time has expired, the system deletes the external SPL outputs. The status variable \$A_STATSID, bit 29 remains set. When reading-back the external outputs in the NCK-SPL via the system variable \$A_OUTSE, "0" is read corresponding to the actual output status.

Behavior of the PLC

If, on the PLC side, it is detected that the communication timeout has been exceeded, then a timer is started with 5 s.

After this time has expired, the PLC goes into Stop (by calling an SFC46). This state can only be exited using a power on.

After the 5s timer has expired, the PLC outputs its own message for diagnostic purposes. At the same time, an entry with the same significance is located in the diagnostics buffer.

Using the status signal DB18.DBX119.5, the SPL programmer and the NCK is provided with the information that the timer was started. This means that he has the possibility of initiating system-specific actions before the PLC goes into the stop condition.

Note

In order to achieve the shortest possible response time, the system variable \$A_STATSID, bit 29 and the status signal DB18.DBX119.5 must be evaluated in the SPL in order to bring the SPL-SGAs as quickly as possible into a safe state (deleted/cleared SPL-SGAs).

Limitations/constraints

The user must take into consideration the following points regarding the functioning of the crosswise data comparison:

Both channels (NCK/PLC) must execute the same logic.

- Do not implement any response sequences or sequence controllers that are externally controlled using short input pulses. This is because short pulses of this type may only be sent and processed in one channel because of sampling effects.
- Unused inputs/outputs/markers of the SPL must be assigned the default value = 0; single-channel use of individual bits for non-safety relevant purposes is not permissible.
An exception is the block \$A_INSI(P) (only up to SW 4.4.29, 5.3.1). These signals are assigned the value "1" by the software in order to make it easier to combine the signals of several axes. This function must be emulated by the user on the PLC side (default of the system variables \$A_INSIPD[1,2] in DB 18 at run-up with "FFFFFFFF"(H). For SW release 5.3.1 and higher, the system behavior with respect to \$A_INSI is precisely the same as for other system variables (can be set using MD 10095: \$MN_SAFE_MODE_MASK).
- External STOPs must be enabled (they are also used internally) and can be extracted from the SPL if required. The "external STOP A" must be parameterized at the SPL interface for all safety axes using MD \$MA_SAFE_EXT_STOP_INPUT[0]. If this condition is not fulfilled, then Alarm 27033 is output.
- Crosswise data comparison checks whether the "commissioning phase" has been completed. If errors are detected in the crosswise data comparison, a "STOP D/E" is triggered on the NCK/611 digital depending on this criterion. If the commissioning phase has not been completed, Alarm 27095 "SPL protection not activated" is displayed once after run-up and the commissioning status between the NCK and PLC cross-checked.

5.10 Safe programmable logic (SPL)

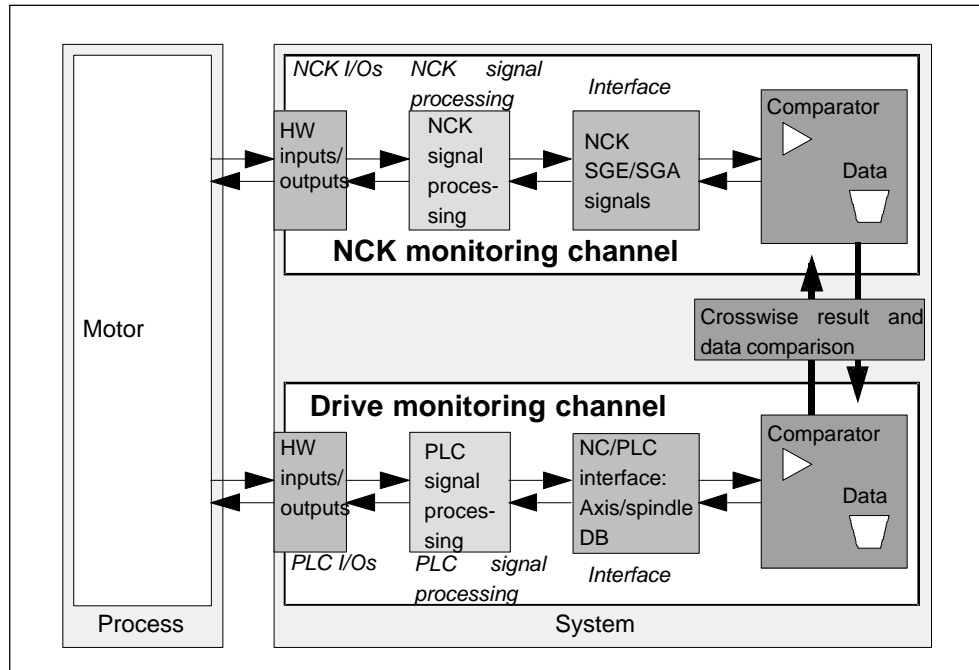

Fig. 5-31 Communications between the NCK-611 digital PLC components

- In the case of a crosswise data comparison error, no system response is initiated regarding the SGE/SGA processed by the SPL. Users must implement this themselves. The only exception is when a system error is detected as was described above.

5.10.1 NCK-SPL program

Description

The NCK-SPL program is written as an NC program (ASUB) with synchronized actions.

Reference: /FBSY/ Description of Functions, Synchronized Actions

Features

The NCK-SPL program has the following features:

- The program can be started manually with NC START during commissioning.
- The following applies once the program has been started:
 - The synchronous actions assigned an ID No. are cyclically executed in the IPO clock cycles (modal)
 - The synchronous actions assigned the keyword IDS remain active even after the operating mode has been changed or NC-STOP/NC RESET
 - In order to check the program, the status of the active synchronous actions (operating area "Machine", soft key "Synchronous actions") can be displayed.
 - The program can be modified during commissioning. It must then be re-started.
 - The NCK-SPL program is saved in the NCK path_N_CST_DIR as sub-routine "_N_SAFE_SPF" (MMC view: Standard cycles/SAFE.SPF). Other sub-routine names are not permitted.
 - After commissioning, the NCK-SPL program must be started using the PLC.
- The images of the PLC safety variables (\$A_INSIP(D), \$A_OUTSIP(D), \$A_INSEP(D), \$A_OUTSEP(D), \$A_MARKERSIP(D)) are required for the simulation (on the NC side) of an SPL. These can be used to develop the SPL step-by-step. They can only be read by the NCK.

5.10 Safe programmable logic (SPL)

Protective mechanisms

- The synchronous action IDs used for the NCK-SPL are protected from being influenced by the PLC or other programs using MD \$MN_PREVENT_SYNACT_LOCK. It is then no longer possible to change these synchronous actions (CANCEL, LOCK have no effect) once _N_SAFE_SPF has been started.
- System variables \$A_OUTSI, \$A_OUTSID, \$A_OUTSE, \$A_OUTSED, \$A_MARKERSI, \$A_TIMERSI and \$A_CMDSI are protected from being written to by programs other than the NCK-SPL (/N_CST_DIR/_N_SAFE_SPF). If an error occurs, Alarm 17070 "Channel %1 block %2 data item write-protected" is output.
- A reference checksum is calculated at run-up by the NCK-SPL (/N_CST_DIR/_N_SAFE_SPF) – it is entered into the program as a comment:
Example: ; SAFE_CHECKSUM = 000476bbH
The checksum is then cyclically re-calculated and compared with the reference checksum. If a deviation is detected, Alarm 27093 "Checksum error NCK-SPL, %1, %2, %3" is output.
- The system variables \$A_INSIP(D), \$A_OUTSIP(D), \$A_INSEP(D), \$A_OUTSEP(D) and \$A_MARKERSIP(D) are only accessible during the commissioning phase.

If NCK-SPL execution is interrupted for any reason or the SI system variables are changed by another program, then this is detected by the cyclic crosswise data comparison with the PLC.

Table 5-47 Response to SPL errors

Event	MD 11500 \$MN_PREVENT_SYNACT_LOCK[m,n] equal to 0	MD 11500 \$MN_PREVENT_SYNACT_LOCK[m,n] not equal to 0
Crosswise data comparison NCK-PLC identifies an error	Alarm 27090 is triggered	Alarm 27090 is triggered and in addition, STOP D/E is triggered
SPL program file is to be changed (written, deleted, re-named, edited)	No response	Alarm 27093 is triggered



Caution

The protective mechanisms that prevent changes to the NCK-SPL file and the NCK-SPL instructions (statements) are only effective if MD \$MN_PREVENT_SYnACT_LOCK[0,1] is not equal to 0.

The machine construction OEM must ensure that the protective mechanisms are activated no later than after the completion of the acceptance test and the values, set in MD \$MN_PREVENT_SYNACT_LOCK[0,1] are documented in the acceptance report.

After commissioning has been completed, the access rights to the SAFE.SPF file must be set to the correct access level for writing/reading/deleting access operations (manufacturer or service).

As long as the protective mechanisms for the NCK-SPL have not been activated (MN_PREVENT_SYNACT_LOCK[0.1] equal to 0), Alarm 27095 is displayed when the crosswise data comparison between the NCK and the PLC starts. This alarm can be acknowledged with the NCK key so that the SPL can be commissioned.

Note

The SPL program must be addressed using upper case letters. Alarm 27097 is output if this is not observed.

5.10.2 Starting the NCK-SPL using the PROG_EVENT mechanism (from SW 6.4.15)

From software release 6.4.15, the NCK-SPL can be started using the PROG_EVENT mechanism.

The PROG_EVENT.SPF cycle (saved under manufacturer cycles ..\DH\CMA.DIR) is started when a specific event occurs (event-controlled program call).

Using the machine data MD 20108 **\$MC_PROG_EVENT_MASK**, for this PROG_EVENT mechanism, certain events are enabled on a specific channel-for-channel basis which then start the cycle.

The following events can be activated as start condition:

- Start of a part program bit 0 == 1
- End of a part program bit 1 == 1
- Operator panel reset bit 2 == 1
- **Run-up** **bit 3 == 1**

5.10 Safe programmable logic (SPL)

The start condition at run-up (bit 3 ==1) must be active in order to start the NCK-SPL (SAFE.SPF) via PROG_EVENT.SPF. The ability to start the NCK SPL via this mechanism – to replace the PLC controlled call via FB4/FC9 – is available from NCU system software 6.4.15 onwards.

Note

When starting the NCK-SPL (SAFE.SPF), it is important that the PROG_EVENT mechanism was started through channel 1. This must be taken into account when parameterizing the channel-specific data MD 20108

\$MC_PROG_EVENT_MASK.

Using the system variable **\$P_PROG_EVENT**, in PROG_EVENT.SPF it can be interrogated as to which event activated the call:

- Start of a part program **\$P_PROG_EVENT == 1**
- End of a part program **\$P_PROG_EVENT == 2**
- Operator panel reset **\$P_PROG_EVENT == 3**
- **Run-up** **\$P_PROG_EVENT == 4**

The call using FB4/FC9 in the PLC program is replaced by calling SAFE.SPF in PROG_EVENT.SPF. For the PROG_EVENT.SPF cycle, MD 11602

\$MN_ASUP_START_MASK (recommended setting = 7H) is taken into account; this can be used to ignore reasons for initiating a stop to run the sequence. The setting in MD 11604 **\$MN_ASUP_START_PRIO_LEVEL** is not relevant for PROG_EVENT.SPF.

SPL status signals from SW 6.4.15

In conjunction with the call of SAFE.SPF using PROG_EVENT.SPF, there are additional bits in the SPL status that can be used to synchronize between the NCK-SPL run and the start of the PLC-SPL.

DB18.DBX137.0 (status bit 8)

This bit is set if the NCK-SPL was started using the PROG_EVENT mechanism. Only the start is displayed and not that SAFE.SPF was successfully executed.

DB18.DBX137.5 (status bit 13)

This bit is set if the end of the SAFE.SPF program is identified. In conjunction with this, the end IDs, **M02**, **M17** or **M30** are permissible for SAFE.SPF as end of program.

If an error occurs while executing SAFE.SPF, and the end of the program has not been reached (e.g. M17), then bit 13 is not set in the SPL status.

This bit can be used in the PLC user program to start the PLC-SPL. This means that the PLC-SPL only starts if the NCK-SPL was completely executed.

Example for PROG_EVENT.SPF

```

; -----
; Event-controlled program call
; PROG_EVENT.SPF under      \DH\CMA.DIR
; -----

; In machine data MD 20108: PROG_EVENT_MASK can be set channel-
; specifically which of the following events will enable the user program:

;      ( ) Start of the part program --> bit 0 == 1
;      ( ) End of the part program   --> bit 1 == 1
;      ( ) Operator panel reset      --> bit 2 == 1
;      (x) Run-up                    --> bit 3 == 1
; -----

; Using the system variable $P_PROG_EVENT, it can be interrogated as to
; which event activated the call:

;      ( ) Start of the part program --> $P_PROG_EVENT == 1
;      ( ) End of the part program   --> $P_PROG_EVENT == 2
;      ( ) Operator panel reset      --> $P_PROG_EVENT == 3
;      (x) Run-up                    --> $P_PROG_EVENT == 4
;

;----- Cycle definition -----
; Suppress single block, display
;-----

N100 PROC PROG_EVENT SBLOF DISPLOF

;
; NCK-SPL start
; -----

N200 IF ($P_PROG_EVENT == 4); Interrogate run-up
N300     CALL "/_N_CST_DIR/_N_SAFE_SPF"
N400 ENDIF
N500 ...
N600 ...
N700 M17 ; End of cycle

The part program SAFE.SPF is called if the system variable check
$P_PROG_EVENT indicated that the part program call PROG_EVENT.SPF was
called when the control system ran-up.

```

5.10 Safe programmable logic (SPL)

Example for SAFE.SPF

A simple example for SAFE.SPF will now be shown that is started using PROG_EVENT when the system runs-up and includes steady-state synchronous actions.

```
; File: SAFE.SPF
=====

; Definitions
DEFINE STOP_A_DISABLE AS $A_OUTSI[1]
DEFINE STOP_C_DISABLE AS $A_OUTSI[2]
DEFINE STOP_D_DISABLE AS $A_OUTSI[3]
;
DEFINE STOP_A_EXT AS $A_INSE[6]
DEFINE STOP_C_EXT AS $A_INSE[7]
DEFINE STOP_D_EXT AS $A_INSE[8]

DEFINE STOP_A_XT AS $A_INSE[9]
;
; Program section
N10 IDS=01 DO STOP_A_DISABLE=STOP_A_EXT
N20 IDS=02 DO $A_OUTSE[1]=NOT $A_OUTSE[1]
N30 M17
```

5.10.3 Starting the NCK-SPL from the PLC user program

Program start

The NCK-SPL can also be started from the PLC user program. As soon as the NCK-SPL has been started, the crosswise data comparison is activated in the system program (NCK and PLC basic program).

The NCK-SPL program must be started as an ASUB. To do this, the interrupt number and channel must first be assigned via FB4 using the ASUB (asynchronous sub-routine) function via parameter PIService="PI.ASUB".

As soon as FB4 has been successfully run (output parameter "Done"=TRUE) the program is executed via FC9 "ASUB" [asynchronous sub-routine].

Starting the PLC-SPL

The PLC-SPL has started in the PLC user program in conjunction with the start of the NCK-SPL via FB4/FC9 if the FC9 has signaled successful execution and has identified that the end of SAFE.SPF has been reached. This is realized using a signal in SAFE.SPF (e.g. \$A_PLCSIOOUT variable, M function or, from SW 6.4.15 onwards, SPL status bit 13 (DB18.DBX137.5)).

SPL status signals

There is an additional bit in the SPL status that can be used to synchronize NCK-SPL execution and the start of the PLC-SPL.

DB18.DBX137.5 (status bit 13) (from SW 6.4.15)

This bit is set if the end of the SAFE.SPF program is identified. In conjunction with this, the end IDs, **M02**, **M17** or **M30** are permissible for SAFE.SPF as end of program.

If an error occurs while executing SAFE.SPF, and the end of the program has not been reached (e.g. M17), then bit 13 is not set in the SPL status.

This bit can be used in the PLC user program to start the PLC-SPL. This means that the PLC-SPL only starts if the NCK-SPL was completely executed.

Parameterizing FB 4

FB4 may only be started in the cyclic mode (OB 1).

Table 5-48 Parameterizing FB 4

Signal	Type	Value range	Meaning
Reg			
PIService	ANY	PI.ASUB	Assign interrupt
Unit	INT	1 to 10 [1]	Channel
WVar1	INT	[1]	Interrupt number
WVar2	INT	[1]	Priority
WVar3	INT	0/1 [0]	LIFTFAST
WVar4	INT	0/1 [0]	BLSYNC
Addr1	STRING	'/_N_CST_DIR/'	NCK-SPL path name
Addr2	STRING	'/_N_SAFE_SPF'	NCK-SPL program name

[values in brackets are standard values required for the call]

Parameterizing FC 9

Table 5-49 Parameterizing FC9

Signal	Type	Type	Value range	Comment
Start	I	Bool		
ChanNo	I	Int	1 to 10 [1]	No. of the NC channel
IntNo	I	Int	1 – 8 [1]	Interrupt No.
Active	O	Bool		1 = active

5.10 Safe programmable logic (SPL)

Table 5-49 Parameterizing FC9

Signal	Type	Type	Value range	Comment
Done	O	Bool		1 = ASUB completed
Error	O	Bool		

[values in brackets are standard values required for the call]

5.10.4 Linking the NCK-SPL to the I/O and monitoring channel

Description

Access to the I/O and the coupling (link) to the NCK monitoring channel are illustrated in the diagram below.

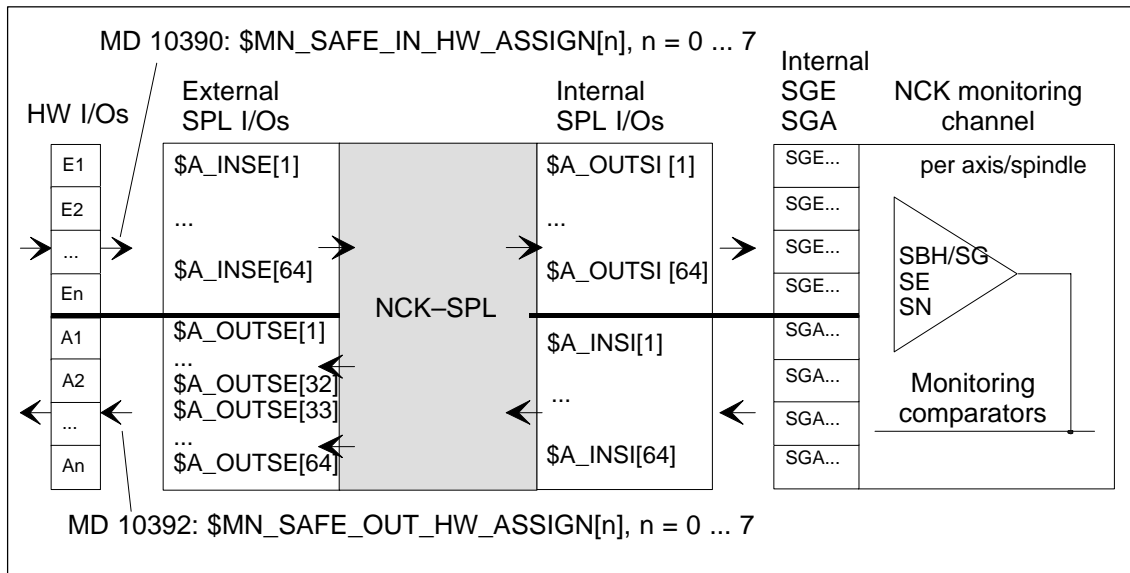

Fig. 5-32 Input/output variables for the NCK-SPL

System variables

The following system variables are available for binary and double-word serial access (32 bits) to the NCK-SPL interfaces:

Table 5-50 System variables for the NCK-SPL

System variables		Description
Binary	Word-serial	
\$A_INSE[1 ... 64]	\$A_INSED[1..2]	System variable for external inputs
\$A_OUTSE[1 ... 64]	\$A_OUTSED[1..2]	System variable for external outputs
\$A_INSI[1 ... 64]	\$A_INSID[1..2]	System variable for internal inputs
\$A_OUTSI[1 ... 64]	\$A_OUTSID[1..2]	System variable for internal outputs
Note: Reading/writing of word-serial variables is the same as access to the binary variables. The variables shown here and other variables are described later in this chapter.		

Coupling to the I/O

The following machine data is available for coupling to the I/Os (external inputs/outputs) (refer to Fig. 5-32):

MD 10390: \$MN_SAFE_IN_HW_ASSIGN[n]
 (assigning an input module to the external SPL inputs \$A_INSE[1 ... 64])

MD 10392: \$MN_SAFE_OUT_HW_ASSIGN[n]
 (assigning an output module to the external SPL outputs \$A_OUTSE[1 ... 64])

Overview of MD for 840D

Table 5-51 Overview of machine data for 840D

Number	Identifier
10390	\$MN_SAFE_IN_HW_ASSIGN[n]
10392	\$MN_SAFE_OUT_HW_ASSIGN[n]
11500	\$MN_PREVENT_SYNACT_LOCK[m,n]
Note: Data is described in Chapter 6.1, "Machine data for SINUMERIK 840D"	

Local binary inputs and outputs on the NCU

The NCU-local binary I/O signals connected at the cable distributor of the NCU box (interface X121) have, up until now, only been available via the system variables \$A_OUT[1...4] and \$A_IN[1...4].

Now, parameterization for both the SPL SGEs and SGAs and the axial SGEs/SGAs has been extended so that local NCU connections can be used.

5.10 Safe programmable logic (SPL)

The connections are parameterized using MD \$MN_SAFE_IN/OUT_HW_ASSIGN for SPL-SGEs/-SGAs and the axial MD \$MA_SAFE_<signal>_INPUT/OUTPUT. Here, a "0" must be entered as the segment data for I/O modules on the 611digital bus instead of a "1".

Changing machine data

In MD \$MN_SAFE_IN_HW_ASSIGN = i s mm xx nn, the distinction is made in the value s (segment number) between parameterizing a system variable and a hardware terminal.

5.10.5 Diagnostics/commissioning

The system variables \$A_INSIP(D), \$A_OUTSIP(D), \$A_INSEP(D) and \$A_OUTSEP(D), and \$A_MARKERSIP(D) are only used for diagnostics and commissioning the NCK-SPL. These system variables represent the input data for crosswise data comparison on the PLC side. They are updated every IPO cycle. They can also be used to access the crosswise data comparison on the PLC side from the NC. This helps when commissioning the SPL:

- Crosswise data comparison function can be temporarily bypassed
- NCK-SPL can be simulated to the process and to the NCK monitoring channel
To do this, the relevant PLC images are written to the variables \$A_OUTSED and \$A_OUTSID as long as there is no NCK-SPL. This means that the NCK-SPL can be commissioned step-by-step. This data may only be accessed during the commissioning phase.

In order to allow the SPL to be commissioned without the crosswise data comparison function constantly responding, the following "minimum NCK-SPL" can be installed in this phase:

```
; Simulate external SPL interface
IDS = 03 DO $A_OUTSED[1]      = $A_OUTSEPD[1]
IDS = 04 DO $A_OUTSED[2]      = $A_OUTSEPD[2]

; Simulate internal SPL interface
IDS = 07 DO $A_OUTSID[1]      = $A_OUTSIPD[1]
IDS = 08 DO $A_OUTSID[2]      = $A_OUTSIPD[2]

; Emulate PLC markers (for all markers used in the PLC)
IDS = 09 DO $A_MARKERSID[1]   = $A_MARKERSIPD[1]
IDS = 10 DO $A_MARKERSID[2]   = $A_MARKERSIPD[2]

; End of program
M17
```

These instructions simulate the output interfaces of the NCK-SPL and therefore "short-circuit" the crosswise data comparison.

**Warning**

The logic used in this phase has a single channel structure and is therefore not safe as defined in control Category 3!

The described minimum NCK-SPL must be replaced by a full NCK-SPL without any access to \$A_INSIP(D), ..., \$A_MARKERSIP(D) when the PLC side is completed!

Additional diagnostic support:

- \$A_STATSID: A value not equal to 0 means that an error has occurred in the crosswise data comparison. The error numbers are selected in the same way as on the PLC side (refer to Chapter 5.10.9, "SPL data on the PLC side").
- \$A_CMDSI[n]: n=1: 10x change timer value for long forced checking procedure pulses and/or single-channel test stop logic.
- \$A_LEVELSID: Indicates how many signals have different signal levels on the NCK and PLC sides that can be presently detected.
- In addition, other NC variables or free R parameters can be written to monitor internal states of the SPL.

The following applies to all system variables of the NCK-SPL outputs:

They can be written from and read back to the SPL program.

5.10.6 Safety software relay (from SW 6.3.30)

The standard SPL block "safety software relay" is designed to meet the requirements of an EMERGENCY STOP function with safe programmable logic. However, it can also be used to implement other similar safety functions, e.g. to control a protective door. Parameter FirstRun must be switched to the value TRUE via a retentive data (memory bit, bit in the data block) at the first run-through after the control has run-up. The data can be preset, e.g. in OB 100. The parameter is reset to FALSE when FB 10 is executed for the first time. Separate data must be used for parameter FirstRun for each call with its own instance.

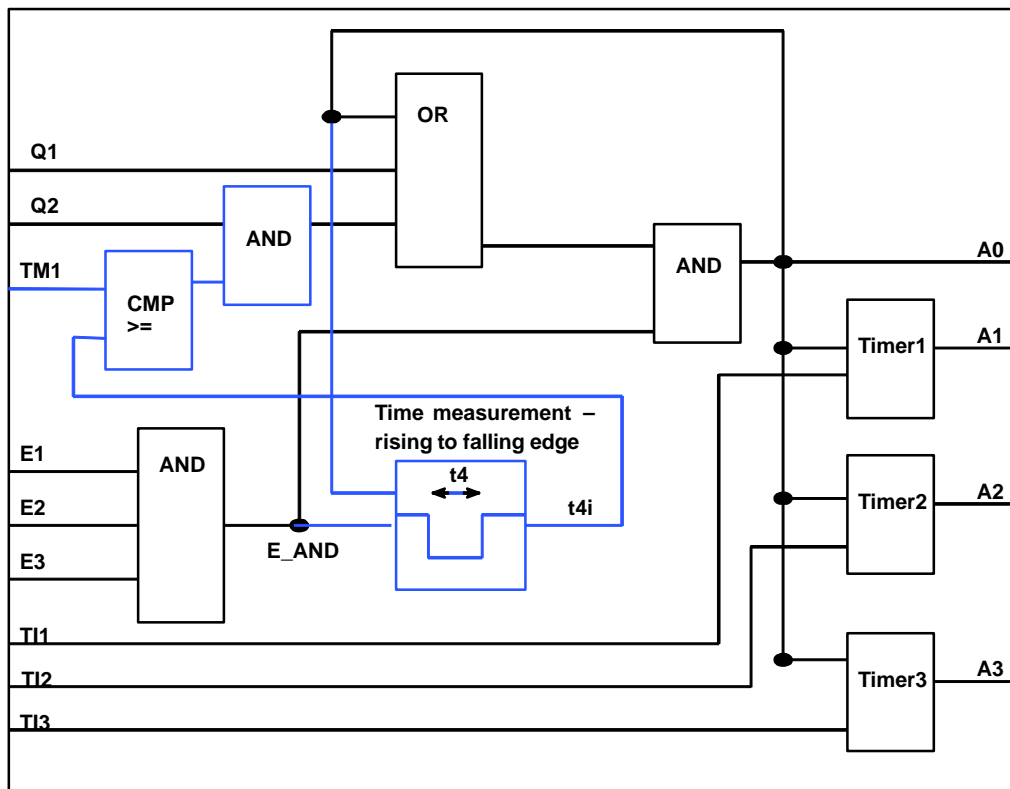

Fig. 5-33 Function diagram of the "safety relay"

The description is provided in the following.

5.10 Safe programmable logic (SPL)

Three shutdown inputs E1 to E3	If one of these inputs is set to 0, direct output A0 is set to 0. Outputs A1 to A3 switch with the delay of timer 1–3. If one of these inputs is not used, then it is internally set to "1" as static signal. One of these inputs must also be used to initiate test operation of the safety relay (forced checking procedure).
Two acknowledge inputs Q1 and Q2	Q1 must be supplied with the signal from the real acknowledge button. Q2 is only used to automatically acknowledge the safety software relay as part of the forced checking procedure. The software relay itself does not have to be subject to a forced checking procedure. However, if the Emergency Stop function is executed and if external actuators have to be subject to a forced checking procedure, if the relay drops-out during the Emergency Stop test, then it can be acknowledged using Q2 (in a defined time window, refer to TM1). This input must also be connected with a safety system variable (even if the signal is not used) – preferably with a \$A_MARKERSI – in order to detect that this acknowledge signal is available as steady-state signal in the crosswise data comparison with the PLC. The associated comparison data in the PLC must have a steady-state 0 signal level (error detection using different states of the particular SPL marker for the PLC and NCK).
Three timer initialization values T11 to T13	The times after which outputs A1 to A3 are switched to 0 at a negative edge in output signal A0 are defined here.
One timer limit value TM1	This limit value is used to define the maximum time that the shutdown inputs E1 to E3 (and their AND logic operation) may have been at a 0 signal level so that they can still be acknowledged using Q2. This therefore guarantees that Q2 can only be effective as automatic acknowledgment for the forced checking procedure within a defined time window after the relay has dropped-out (after it has been de-energized). It is not permissible that Q2 is used to acknowledge a "real" shutdown.
Four output values A1 to A3	A0 supplies the result of ANDing E1 to E3 without any delay. Outputs A1 to A3 supply the same result for positive edges of A0; for negative edges, the results are delayed by the timer initialization T11 to T13. A0 to A3 do not produce a result after run-up until an acknowledgment has been received via Q1.

Initialization in the part program

The connections for the function block are defined when initialized. The input and output quantities of the function block are assigned to the required system variables (\$A_MARKERSI, \$A_INSE, \$A_OUTSE,...). The following functions must be called:

5.10 Safe programmable logic (SPL)

SIRELIN: This language command assigns the input quantities Q1, Q2, E1, E2 and E3 to the safety relay x (x = 1..4). The return value contains the number of the first incorrect parameter; a value of 0 indicates that the parameter assignment is correct.

Syntax: SIRELIN(x,status,"Q1","Q2","E1","E2","E3")

The transfer parameters Q1 to E3 are strings and must therefore be entered in quotation marks (" "). The following system variables are permissible as input quantities:

\$A_MARKERSI[]

\$A_INSE[]

\$A_INSI[]

\$A_OUTSE[]

\$A_OUTSI[]

E2 and E3 are optional. If these parameters are not entered, the relevant inputs are set to "1" (static signal).

SIRELOUT: This language command assigns the output quantities A0, A1, A2 and A3 to safety relay x (x = 1..4). The return value contains the number of the first incorrect parameter; a value of 0 indicates that the parameter assignment is correct.

Syntax: SIRELOUT(x,status,"A0","A1","A2",A3")

The transfer parameters A0 to A3 are strings and must therefore be entered in quotation marks (" "). The following system variables are permissible as output quantities:

\$A_MARKERSI[]

\$A_OUTSE[]

\$A_OUTSI[]

\$A_PLCSIOUT[]

A1 to A3 are optional. If these parameters are not specified, then the corresponding outputs are not supplied. However, if A1 is specified, the initialization value for timer 1 (TI1) must also be parameterized via SIRELTIME. The same applies for A2 and timer 2 (TI2) and A3 and timer 3 (TI3).

SIRELTIME: This language command assigns the times – for the timers required – to safety relay x (x = 1..4). These include the timer limit value TM1 and the timer initialization values TI1, TI2 and TI3. The return value contains the number of the first incorrect parameter; a value of 0 indicates that the parameter assignment is correct.

Syntax: SIRELTIME(x,status,TM1,TI1,TI2,TI3)

Transfer parameters TM1 to TI3 are REAL numbers (timers in seconds). TI1 to TI3 are optional. If these parameters are not specified, the corresponding outputs A1 to A3 are not supplied. However, if TI1 is specified, output A1 must also be parameterized via SIRELOUT. The same applies for TI2 and A2 and TI3 and A3.

Note

- The initialization language commands must be directly included in the part program (e.g. SAFE.SPF); they may not be used in synchronized actions! If this condition is violated, Alarm 12571, "Channel 1 Block %2 %3 not permitted in synchronized motion" is triggered.
- As described above, there is an interdependency between the number of the optional parameters for the language commands SIRELTIME and SIRELOUT. This interdependency is checked in the language command that comes later in the part program sequence. If, for example, A2 is no longer parameterized in SIRELOUT, but TI2 is specified in SIRELTIME, then this parameter is identified as being incorrect!

Cyclic sequence

The correctly timed call in the SPL is made using the language command SIRELAY. A calling parameter is not required in the cyclic section except to select the desired relay x ($x = 1.4$). Initialization must be carried-out beforehand. If this is not correctly done, then this is indicated in the return value of the language command SIRELAY. The cyclic section must be integrated in the synchronized actions of the SPL.

Syntax: status = SIRELAY(x)

The following values are possible for status:

Return value status	Meaning
1	The input quantity of the safety relay is either not parameterized or not correctly parameterized. Remedy: Call SIRELIN with the correct parameterization
2	The output quantities of the safety relay are either not parameterized or not correctly parameterized. Remedy: Call SIRELOUT with the correct parameterization
3	The input and output quantities of the safety relay are either not parameterized or not correctly parameterized. Remedy: Call SIRELIN and SIRELOUT with the correct parameterization
4	The timers of the safety relay are either not parameterized or not correctly parameterized. Remedy: Call SIRELTIME with the correct parameterization
5	The input quantities and timers of the safety relay are either not parameterized or not correctly parameterized. Remedy: Call SIRELIN and SIRELTIME with the correct parameterization

5.10 Safe programmable logic (SPL)

Return value status	Meaning
6	The output quantities of the safety relay are either not parameterized or not correctly parameterized. Remedy: Call SIRELOUT and SIRELTIME with the correct parameterization
7	The initialization of the safety relay was either not carried-out or not correctly carried-out. Remedy: Call SIRELIN, SIRELOUT and SIRELTIME with the correct parameterization

Note

1. The SIRELAY call must be made in the NCK-SPL (program SAFE.SPF), since the allocation of the output quantities corresponds to the write access operations to safety system variables. If the call comes from a different program, Alarm 17070 "Channel %1 Block %2 Data write-protected" is output.
2. The SIRELAY call must be included in a synchronized action. If this condition is not satisfied, Alarm 12080, "Channel %1 Block %2 Syntax error for text SIRELAY" is output.
3. If parameter x contains a value that lies outside the range 1 to 4, Alarm 20149 "Channel %1 Block %2 Motion synchronous action: Invalid index" is output.

Forced checking procedure

When the safety relay is tested, acknowledge input Q2 and one of the three disable inputs (E1, E2 or E3) must be used. Q2 must be connected to a safety marker (\$A_MARKERSI[]) and may only be briefly set (< 1s) to 1.

One of the three inputs E1 to E3 can be used (e.g. from the PLC) with a short falling edge to check that the safety relay has dropped-out. The 0 signal level may not be present for longer than the time parameterized in TM1. The maximum value for TM1 is 1s, as otherwise the crosswise data comparison between NCK and PLC-SPL would detect an error.

Acknowledge input Q2 can only be used if the measured time t4 is shorter than TM1. This prevents a queued shutdown operation being acknowledged externally via the test acknowledge input. If A0 is 1 at the time of the falling edge of E_AND (= ANDing of E1, E2 and E3), time t4i (refer to Fig. 5-33) is allocated the measured time t4. For additional measurements, while A0 remains at 0, t4i is only re-saved if the measured time t4 is greater than the old value of t4i.

Limitations/constraints

The language commands SIRELIN, SIRELOUT and SIRELTIME may not be used in synchronized actions.

The language command SIRELAY may only be used in synchronized actions of the SPL (SAFE.SPF). The connection must be specified beforehand using the language commands SIRELIN, SIRELOUT and SIRELTIME.

Example

Example of an Emergency Stop implemented using NCK-SPL in SAFE.SPF:

```

DEF          INT RESULT_IN, RESULT_OUT, RESULT_TIME

N10 DEFINE IE_NH_E          AS $A_INSE[1]
N20 DEFINE IE_NH_Q          AS $A_INSE[2]
N30 DEFINE MI_NH_Q          AS $A_MARKERSI[1]
N40 DEFINE MI_C_ABW         AS $A_MARKERSI[2]
N50 DEFINE MI_A_ABW_A       AS $A_MARKERSI[3]
N60 DEFINE MI_A_ABW_S       AS $A_MARKERSI[4]
N70 DEFINE M_STATUS_1      AS $AC_MARKER[1]

;-----
N200 SIRELIN(1,RESULT_IN,"IE_NH_Q","MI_NH_Q","IE_NH_E")
N210 SIRELOUT(1,RESULT_OUT,"MI_C_ABW",MI_A_ABW_A,"MI_A_ABW_S")
N220 SIRELTIME(1,RESULT_TIME,0.4, 2.2, 3.5)
;-----
N300 IDS=10 DO M_STATUS_1 = SIRELAY(1)
-----Error handling-----
N310 IDS=11 EVERY M_STATUS_1 < > DO . . . . .

```

5.10 Safe programmable logic (SPL)

FUNCTION_BLOCK FB 10

Declaration of the function

```

VAR_INPUT
    In1 : BOOL := True ;           // Input 1
    In2 : BOOL := True ;           // Input 2
    In3 : BOOL := True ;           // Input 3
    Quit1 : BOOL ;                 // Ackn1 signal
    Quit2 : BOOL ;                 // Ackn2 signal
    TimeValue1 : TIME := T#0ms ;   // TimeValue for Output 1
    TimeValue2 : TIME := T#0ms ;   // TimeValue for Output 2
    TimeValue3 : TIME := T#0ms ;   // TimeValue for Output 3
END_VAR

VAR_OUTPUT
    Out0 : BOOL ;                 // Output without Delay
    Out1 : BOOL ;                 // Delayed Output to False by Timer 1
    Out2 : BOOL ;                 // Delayed Output to False by Timer 2
    Out3 : BOOL ;                 // Delayed Output to False by Timer 3
END_VAR

VAR_INOUT
    FirstRun : BOOL ;             // True by User after 1. Start of SPL
END_VAR

```

The following table shows all formal parameters of the SI relay function:

Signal	Type	Type	Comment
In1	I	BOOL	Input 1
In2	I	BOOL	Input 2
In3	I	BOOL	Input 3
Quit1	I	BOOL	Acknowledge input 1
Quit2	I	BOOL	Acknowledge input 2
TimeValue1	I	TIME	Value 1 for switch-off delay
TimeValue2	I	TIME	Value 2 for switch-off delay
TimeValue3	I	TIME	Value 3 for switch-off delay
Out0	O	BOOL	Output, instantaneous (no delay)
Out1	O	BOOL	Output, delayed by TimeValue1
Out2	O	BOOL	Output, delayed by TimeValue2
Out3	O	BOOL	Output, delayed by TimeValue3
FirstRun	I/O	BOOL	Activates the initial state

Note

The block must be called cyclically by the user program beginning from when the PLC program is started. The user must provide an instance DB with any number for this purpose. The call is multi-instance-capable.

5.10.7 System variables for SINUMERIK 840D

The following system variables can only be used in conjunction with SINUMERIK® Safety Integrated. They are used when programming the safe programmable logic (SPL).

Table 5-52 Overview of system variables

System variables	Meaning	Value range	Data type	Possible access for			
				Part program		Synchr. action	
				r	w	r	w
Actual position							
\$VA_IS[axis]	Safe actual position for Safety Integrated		DOUBLE	x		x	
\$AA_IM[axis]	Actual position of the closed-loop control		DOUBLE	x		x	
\$VA_IM[axis]	Encoder actual value in the machine coordinate system		DOUBLE	x		x	
Error status							
\$A_XFAULTSI	In the crosswise data comparison between NCK and 611D of any axis, an actual-value error has been detected		INT	x		x	
\$VA_XFAULTSI[axi s name]	The crosswise data comparison for this axis between NCK and 611D has detected an actual value error		INT	x		x	
\$VA_STOPSI	Actual Safety Integrated Stop for the particular axis		INT	x		x	
\$A_STOPESI	Actual Safety Integrated STOP E for any any axis		INT	x		x	

5.10 Safe programmable logic (SPL)

Table 5-52 Overview of system variables

				r	w	r	w
Internal SPL inputs/outputs							
\$A_INSI[n]	NCK input	n = 1, 2, ... 64 stand for the No. of the input	BOOL	x		x	
\$A_INSID[n]	NCK inputs	n = 1,2	INT	x		x	
\$A_INSIP[n]	Image, PLC input	n = 1,2, ...64	BOOL	x		x	
\$A_INSIPD[n]	Image of the PLC inputs	n = 1,2	INT	x		x	
\$A_OUTSI[n]	NCK output	n = 1, 2, ... 64 stand for the No. of the output	BOOL	x	x	x	x
\$A_OUTSID[n]	NCK outputs	n = 1,2	INT	x	x	x	x
\$A_OUTSIP[n]	Image, PLC output	n = 1, 2, ... 64	BOOL	x		x	
\$A_OUTSIPD[n]	Image of the PLC outputs	n = 1,2	INT	x		x	
External SPL inputs/outputs							
\$A_INSE[n]	NCK input	n = 1, 2, ... 64 stand for the No. of the input	BOOL	x		x	
\$A_INSED[n]	NCK inputs	n = 1,2	INT	x		x	
\$A_INSEP[n]	Image of PLC input	n = 1, 2, ... 64 stand for the No. of the input	BOOL	x		x	
\$A_INSEPD[n]	Image of the PLC inputs	n = 1,2	INT	x		x	
\$A_OUTSE[n]	NCK output	n = 1, 2, ... 64 stand for the No. of the output	BOOL	x	x	x	x
\$A_OUTSED[n]	NCK outputs	n = 1,2	INT	x	x	x	x
\$A_OUTSEP[n]	Image of a PLC output	n = 1, 2, ... 64 stand for the No. of the output	BOOL	x		x	
\$A_OUTSEPD[n]	Image of the PLC outputs	n = 1,2	INT	x		x	
SPL markers and timers							
\$A_MARKERSI[n]	Bit memories	n = 1, 2, ... 64 stands for the No. of the marker	BOOL	x	x	x	x
\$A_MARKERSID[n]	Bit memories	n = 1, 2	INT	x	x	x	x
\$A_MARKERSIP[n]	Image of the PLC markers	n = 1,2, ...64	BOOL	x		x	
\$A_MARKER- SIPD[n]	Image of the PLC markers	n = 1, 2	INT	x		x	

Table 5-52 Overview of system variables

				r	w	r	w
\$_A_TIMERSI[n]	Timer	n = 1, 2...16 stand for the No. of the timer	REAL	x	x	x	x
\$_A_STATSID	Crosswise data comparison error triggered if the value is not equal to 0	n = 0 error not initiated n = 1 error initiated	INT	x		x	
\$_A_CMDSI	10x change timer value for long forced checking procedure pulses and/or single-channel test stop logic	Bit 0 = 1 10x time active	BOOL	x	x	x	x
\$_A_LEVELSID	Crosswise data comparison stack level display: Number of signals for which NCK and PLC detect different signal levels	0...320	INT	x		x	
\$_A_PLCSIIN	Single-channel communication between NCK and PLC SPL		BOOL	x		x	
\$_A_PLCSIOUT	Single-channel communication between NCK and PLC SPL		BOOL	x		x	
Note: r -> read, w -> write							

5.10.8 Behavior after power on/mode change/reset

1. After the system has run-up the following Safety Integrated system variables are assigned the value zero:

\$A_INSE(D),
 \$A_OUTSE(D),
 \$A_OUTSI(D),
 \$A_MARKERSI(D),
 \$A_INSEP(D),
 \$A_OUTSEP(D),
 \$A_OUTSIP(D),
 \$A_MARKERSIP(D).

2. If SGAs are linked to the SPL interface \$A_INSI(D) using axial MDs, these system variables are pre-assigned a value of "1" at run-up (up to SW 4.4.29, 5.31). This applies for double-word notation:
 \$A_INSI[1...32] uses → \$A_INSID[1] pre-assigned with FFFF FFFF (H).
 \$A_INSI[33...64] uses → \$A_INSID[2] pre-assigned with FFFF FFFF (H). This behavior must be emulated in the PLC-SPL.
 With SW 4.4.29, 5.3.1 and higher, the system behavior with respect to \$A_INSI is exactly the same as for other system variables.
3. Pre-assignment of other variables before cyclic processing of the NCK-SPL starts can be programmed in the same part program as the NCK-SPL itself. To ensure that the pre-assignment instructions are only performed once, they must use the following syntax:

```
IDS=<No.> WHEN TRUE DO<Run-up instructions>
```

As a result of the identifier IDS, the events "operating mode change" and "reset" have no effect on the processing of the NCK-SPL.

4. Several run-up instructions can be programmed in one block.

5.10.9 SPL data on the PLC side

The safe programmable logic of the PLC (PLC-SPL) is a sub-function of the safety functions integrated in the SINUMERIK.

Signals

The PLC-SPL signals are in DB18 and are sub-divided into

1. Parameterization part, and
2. Data area/status.

Parameterization part

The link to the I/Os (external inputs/outputs) is implemented using the parameterization data INSEP_ADDR[1...8] and OUTSEP_ADDR[1...8] in conjunction with the activation bits INSEP_VALID[1...8] and OUTSEP_VALID[1...8].

The data area INSEP[1...64]/OUTSEP[1...64] is assigned to the input/output image using this parameterization data.

The data areas are assigned byte-serially and in any sequence.

INSEP_VALID/OUTSEP_VALID = TRUE:

When activation bits INSEP_VALID[1...8] and OUTSEP_VALID[1...8] are set to TRUE, the basic program transfers the parameterized inputs/outputs to the relevant data area INSEP/OUTSEP.

INSEP_VALID/OUTSEP_VALID = FALSE:

If an activation signal is FALSE, no transfer is made in the associated INSEP/OUTSEP data byte. In this case, the supply of this data byte can be organized by the user program.

SPL_READY:

The SPL_READY = TRUE signal indicates that the commissioning phase has been completed, i.e. if a crosswise data comparison error has occurred, the basic program sends a "STOP D/E" to all the axes.

Data area/status

SPL_DATA:

The useful (net) data for the PLC-SPL is contained in the SPL_DATA structure.

The useful data area is sub-divided into internal inputs/outputs and marker areas and external inputs/outputs that correspond to the hardware I/Os.

With the appropriate parameterization for external inputs/outputs, the basic program transfers the input image of the I/Os to the external inputs in DB 18 and from the external outputs in DB 18 to the output.

SPL_DELTA:

The SPL_DELTA area is used for diagnostics. A signal with the status TRUE in this area means that the signal is different in the NCK and PLC at this bit position.

CMDSI:

Signal CMDSI can be used to extend the timeout value in the crosswise SPL data comparison by a factor of 10. This extension is used for long forced checking procedure pulses or single-channel test stop logic functions.

STATSI:

A crosswise data comparison error is indicated in STATSI. STATSI contains the number of the signal whose signal difference caused this error. The error number (1-320) refers to SPL_DATA as an array with $5 \times 64 = 320$ signals.

5.10 Safe programmable logic (SPL)

LEVELSI:

LEVELSI is used for diagnostics and indicates how many signals with different signal levels are present.

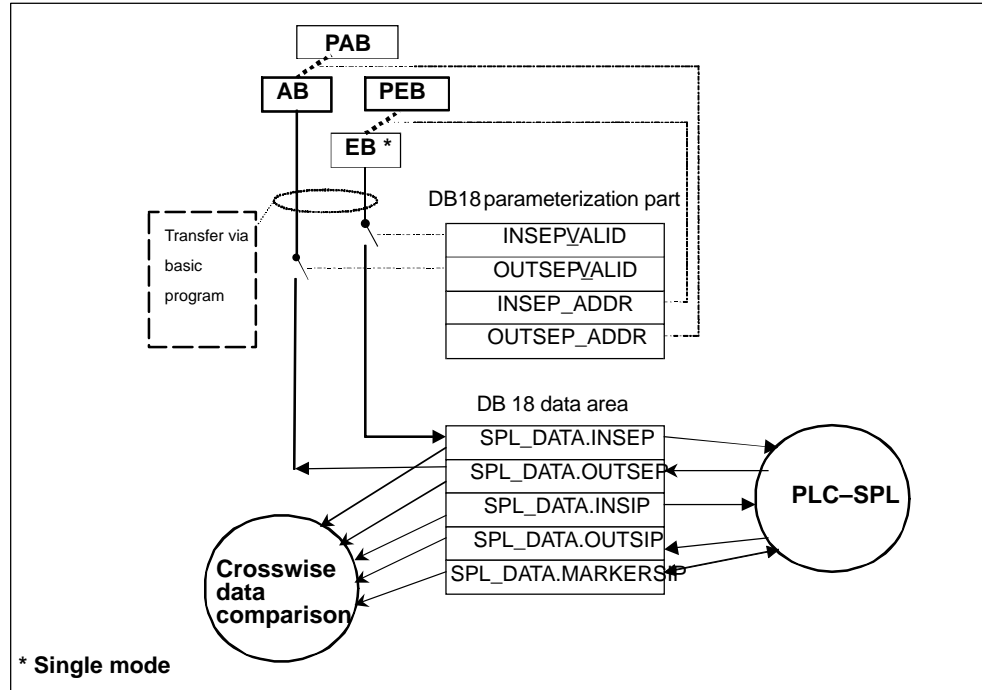

Fig. 5-34 Mode of operation of the PLC-SPL program with DB 18

Configuring sensors

Sensors with exclusive OR'ed output signals must be configured in such a way that in the safe state the 0 signal level is present on the NCK side and the 1 signal level on the PLC side. The PLC-SPL program must invert the sensor signal so that the same signal level appears in DB18 as is active on the NCK side. Otherwise the crosswise data comparison function would signal an error condition. The user program must handle the data transfer into the DB18 for such signals because the basic program can only copy but it cannot invert.

Crosswise data comparison

The crosswise data comparison between the PLC and NCK is performed cyclically. If a difference is detected, Alarm "Error for crosswise data comparison NCK-PLC" is output. A STOP D/E is also triggered.

The crosswise data comparison between the PLC and the NCK includes all of the signals that are received at the SPL, signals generated by the SPL and internal states of the SPL:

SPL_DATA.INSEP[1...64]
 SPL_DATA.OUTSEP[1...64]
 SPL_DATA.INSIP[1...64]
 SPL_DATA.OUTSIP[1...64]
 SPL_DATA.MARKERSIP[1...64]

Important requirement – "the commissioning phase must have been completed"

The important requirement "the commissioning phase completed", is derived from the NCK MD \$MN_PREVENT_SYNACT_LOCK[0,1] in the NCK. If one of the two field entries is not equal to 0, "commissioning phase completed" is set internally by the crosswise data comparison. On the PLC side, this requirement is entered using DB18.DBX36.0. If this bit is set to "1", then the commissioning phase is considered to have been completed.

Any changes to data on the NCK and PLC side do not take effect until after power on.

Note

A complete crosswise data comparison is always carried-out involving all 64 INSE/OUTSE even if only 4 INSE or OUTSE are enabled by the SI-BASIC option (from SW 7).

5.10.10 Direct communications between the NCK and PLC-SPL (from SW 6.3.30)

In SPL applications, a certain degree of single-channel communications between the two SPLs (NCK and PLC) is always required in addition to safety-related switching elements being connected through two channels. Test stop and Emergency Stop acknowledgments are typical applications. Today, there are various ways of doing this:

1. The NCK and PLC are connected through external wiring
2. Communication via simulated NCK I/Os (\$A_OUT/\$A_IN; DB10)
3. Communication via FC21 and NCK system variables \$A_DBB etc.

The availability of these communication paths depends on the functional scope of the machine.

5.10 Safe programmable logic (SPL)

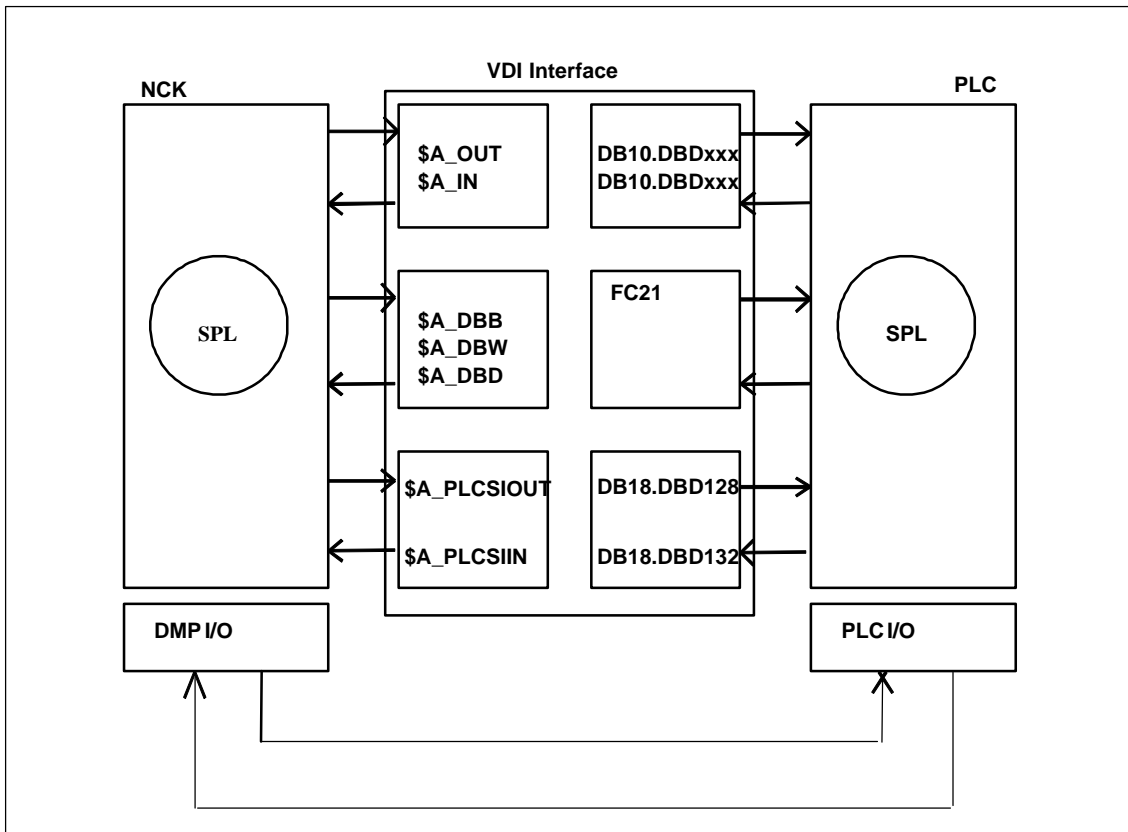

Fig. 5-35 NCK-PLC communication paths

In order to be able to exchange single-channel SI-specific signals between the NCK and PLC in a dedicated data area, a corresponding communication interface has been introduced for these components. This allows SI applications running on the NCK and PLC (SPL) to be able to communicate in separate, autonomous data areas that cannot be occupied by other system functions. On the PLC side, this interface represents an extension of DB18; on the NCK side, new system variables have been introduced for this interface and these are available to the user. The meaning of the individual bits in this interface are defined by the user.

NCK	PLC	
\$A_PLCSIOUT[1...32]	DB18.DBD128	32 bits from the NCK to PLC
\$A_PLCSIIN[1...32]	DB18.DBD132	32 bits from the PLC to NCK

For status queries on the PLC side, DB18 is supplemented by the SPL run-up status already displayed on the NCK in the SI service screen.

NCK	PLC	
-	DB18.DBW136	16-bit run-up status

Limitations/constraints

System variables \$A_PLCSIOUT[1...32] and \$A_PLCSIIN[1...32] are protected so that they cannot be accessed from other programs, except the NCK-SPL program (SAFE.SPF). A corresponding programming command is rejected with the Alarm 17070 "Channel %1 Block %2 Data write-protected".

5.10 Safe programmable logic (SPL)

5.10.11 PLC data block (DB 18)

Parameterization part

DB 18		Signals for safety SPL						
Data block		Interface PLC → PLC						
Byte	Bit 7	Bit 6	Bit 5	Bit 4	Bit 3	Bit 2	Bit 1	Bit 0
DBB 0	<i>INSEP Valid (valid bit)</i>							
	8th input byte	7th input byte	6th input byte	5th input byte	4th input byte	3rd input byte	2nd input byte	1st input byte
DBB1								
DBB 2	<i>OUTSEP Valid (valid bit)</i>							
	8th output byte	7th output byte	6th output byte	5th output byte	4th output byte	3rd output byte	2nd output byte	1st output byte
DBB 3								
DBW4	INSEP_ADDR (address 1st input byte)							
DBW6	INSEP_ADDR (address 2nd input byte)							
DBW8	INSEP_ADDR (address 3rd input byte)							
DBW10	INSEP_ADDR (address 4th input byte)							
DBW12	INSEP_ADDR (address 5th input byte)							
DBW14	INSEP_ADDR (address 6th input byte)							
DBW16	INSEP_ADDR (address 7th input byte)							
DBW18	INSEP_ADDR (address 8th input byte)							
DBW20	OUTSEP_ADDR (address 1st output byte)							
DBW22	OUTSEP_ADDR (address 2nd output byte)							

DB 18		Signals for safety SPL						
DBW24								OUTSEP_ADDR (address 3rd output byte)
DBW26								OUTSEP_ADDR (address 4th output byte)
DBW28								OUTSEP_ADDR (address 5th output byte)
DBW30								OUTSEP_ADDR (address 6th output byte)
DBW32								OUTSEP_ADDR (address 7th output byte)
DBW34								OUTSEP_ADDR (address 8th output byte)
DBB36								Stop E
DBB37								SPL_READY

Data area/errors

DB 18		Signals for safety SPL						
Data block		Interface PLC → NCK						
Byte	Bit 7	Bit 6	Bit 5	Bit 4	Bit 3	Bit 2	Bit 1	Bit 0
	<i>Data area of SPL inputs/outputs</i>							
DBD 38								SPL_DATA.INSEP[1...32]
DBD 42								SPL_DATA.INSEP[33...64]
DBD 46								SPL_DATA.OUTSEP[1...32]
DBD 50								SPL_DATA.OUTSEP[33...64]
	<i>Data area for user SPL</i>							
DBD 54								SPL_DATA.INSIP[1...32]
DBD 58								SPL_DATA.INSIP[33...64]
DBD 62								SPL_DATA.OUTSIP[1...32]

5.10 Safe programmable logic (SPL)

DB 18	Signals for safety SPL						
DBD 66	SPL_DATA.OUTSIP[33...64]						
DBD 70	SPL_DATA.MARKERSIP[1...32]						
DBD 74	SPL_DATA.MARKERSIP[33...64]						
<i>Difference in signal level NCK – PLC for diagnostics</i>							
DBD 78	SPL_DELTA.INSEP[1 ...32]						
DBD 82	SPL_DELTA.INSEP[33 ...64]						
DBD 86	SPL_DELTA.OUTSEP[1 ...32]						
DBD 90	SPL_DELTA.OUTSEP[33 ...64]						
DBD 94	SPL_DELTA.INSIP[1 ...32]						
DBD 98	SPL_DELTA.INSIP[33 ...64]						
DBD 102	SPL_DELTA.OUTSIP[1 ...32]						
DBD 106	SPL_DELTA.OUTSIP[33 ...64]						
DBD 110	SPL_DELTA.MARKERSIP[1 ...32]						
DBD 114	SPL_DELTA.MARKERSIP[33 ...64]						
DBB 118							CMDSI
DBB 119	System error, cross-wise data comparison						
DBD 120	Error number 0 = no error 1 – 320 = signal number starting from SPL_DATA.INSEP[1]						
DBD 124	Crosswise data comparison stack level display (diagnostics capability: How many SPL signals currently have different levels)						

Additional data areas

DB 18		Signals for safety SPL						
Data block		Interface PLC → NCK						
Byte	Bit 7	Bit 6	Bit 5	Bit 4	Bit 3	Bit 2	Bit 1	Bit 0
	<i>Data area of single-channel inputs/outputs</i>							
DBB128	PLCSIOUT[1 ...8]							
DBB129	PLCSIOUT[9 ...16]							
DBB130	PLCSIOUT[17 ...24]							
DBB131	PLCSIOUT[25 ...32]							
DBB132	PLCSIIN[1 ...8]							
DBB133	PLCSIIN[9 ...16]							
DBB134	PLCSIIN[17 ...24]							
DBB135	PLCSIIN[25 ...32]							
DBW136	SPL status							
DBB138	PROFIsafe module(s) for							
	8th input byte	7th input byte	6th input byte	5th input byte	4th input byte	3rd input byte	2nd input byte	1st input byte
DBB139								
DBB140	PROFIsafe module(s) for							
	8th output byte	7th output byte	6th output byte	5th output byte	4th output byte	3rd output byte	2nd output byte	1st output byte
DBB141								
DBB142 to DBB149								

5.10 Safe programmable logic (SPL)

DB 18	Signals for safety SPL							
DBB150 to DBB157								
DBB158 to DBB188								

SPL status signals for DB18.DBW136

DB18.DBX136.0	SPL_STATUS[1]	NCK-SPL interfaces parameterized
DB18.DBX136.1	SPL_STATUS[2]	NCK-SPL program file exists
DB18.DBX136.2	SPL_STATUS[3]	NCK waits for the PLC to run-up
DB18.DBX136.3	SPL_STATUS[4]	NCK and PLC in cyclic operation
DB18.DBX136.4	SPL_STATUS[5]	Call FB4 processing for SPL
DB18.DBX136.5	SPL_STATUS[6]	End FB4 processing on NCK
DB18.DBX136.6	SPL_STATUS[7]	Call FC9 processing for SPL
DB18.DBX136.7	SPL_STATUS[8]	End FC9 processing on NCK
DB18.DBX137.0	SPL_STATUS[9]	SPL started via PROG_EVENT mechanism (from SW 6.4.15)
DB18.DBX137.1	SPL_STATUS[10]	Crosswise data comparison started, NCK
DB18.DBX137.2	SPL_STATUS[11]	Crosswise data comparison started, PLC
DB18.DBX137.3	SPL_STATUS[12]	NCK-SPL checksum checking active
DB18.DBX137.4	SPL_STATUS[13]	All SPL protective mechanisms active
DB18.DBX137.5	SPL_STATUS[14]	End of SPL program reached
DB18.DBX137.6	SPL_STATUS[15]	not assigned
DB18.DBX137.7	SPL_STATUS[16]	not assigned

Table 5-53 Overview of DB 18 signals

DB18				
Signal	r – read w – write	Type	Value range	Comment
Parameterization part				
INSEP_VALID[1..8]	r/w	Bool		0 = INSEP[1..8] No automatic transfer, can be supplied from the user program (AWP) 1 = Transfer of input byte, specified in INSEP_ADDR[1..8] to INSEP[1..8] by the basic program

5.10 Safe programmable logic (SPL)

Table 5-53 Overview of DB 18 signals

Signal	r – read w – write	Type	Value range	Comment
OUTSEP_VALID[1..8]	r/w	Bool		0 = OUTSEP[1..8] No automatic transfer, can be retrieved from the user program (AWP) 1 = Transfer to output byte defined in OUTSEP[1..8] from OUTSET_ADDR[1..8] by the basic program
INSEP_ADDR[1..8]	r/w	Int	1..EB max	Address, input byte
OUTSEP_ADDR[1..8]	r/w	Int	1..AB max	Address, output byte
SPL_READY	r/w	Bool		0 = commissioning phase (for a crosswise data comparison error, a STOP D is not initiated) 1 = commissioning completed (for a crosswise data comparison error, STOP D is initiated)
STOP E				If DB18, DBX36.1 was set to 1, for a crosswise data comparison error, instead of an external STOP D, an external STOP E is transferred to the drive
Data area/status				
SPL_DATA				Net (useful) data:
INSEP[1..64]	r	Bool		External PLC input for the SPL
OUTSEP[1..64]	r/w	Bool		External PLC output for the SPL
INSIP[1..64]	r	Bool		Internal PLC input for the SPL
OUTSIP[1..64]	r/w	Bool		Internal PLC output for the SPL
MARKERSIP[1..64]	r/w	Bool		Marker for SPL
SPL_DELTA				Signal differences for diagnostics:
INSEP[1..64]	r	Bool		External PLC input for the SPL
OUTSEP[1..64]	r	Bool		External PLC output for the SPL
INSIP[1..64]	r	Bool		Internal PLC input for the SPL
OUTSIP[1..64]	r	Bool		Internal PLC output for the SPL
MARKERSIP[1..64]	r	Bool		Marker for SPL
CMSI	r/w	Bool		The timeout value in the crosswise data comparison is extended by a factor of 10
STATSI	r	Dint	1 – 320	Status: 0 – no error 1 – 320 error No. corresponds to signal from SPL_DATA whose signal level difference resulted in a crosswise data comparison error

5.10 Safe programmable logic (SPL)

Table 5-53 Overview of DB 18 signals

Signal	r – read w – write	Type	Value range	Comment
LEVELSI	r	Dint		Crosswise data comparison stack level display (diagnostics capability: How many SPL signals currently have different levels)
PLCSIIN	r/w	Bool	1 – 32	Single-channel signals from the PLC to NCK
PLCSIOUT	r	Bool	1 – 32	Single-channel signals from the NCK to the PLC

5.10.12 Forced checking procedure of SPL signals

SPL signals

The forced checking procedure of SPL signals is a part of the SPL functionality. After the external safety circuit has been connected-up, a two-channel SPL has been created and the appropriate safety functions engineered/configured and tested using the acceptance test, the correct functioning, of the functions verified using the acceptance test, should be permanently ensured:

- **External** inputs/outputs
The external inputs/outputs of the SPL (\$A_INSE or \$A_OUTSE) must be subject to a forced checking procedure to ensure that faults (e.g. wire breakage) do not accumulate over a period of time which would mean that both monitoring channels could fail.
- **Internal** inputs/outputs
Internal inputs/outputs (\$A_INSI, \$A_OUTSI), markers (\$A_MARKERSI) etc. (\$A_TIMERSI) do not have to be subject to a forced checking procedure. It will always be possible to detect an error at these locations due to the differing two-channel responses of the external inputs/outputs or the NCK/611 digital monitoring channels; crosswise data comparison is carried-out at both ends of the response chain to detect any errors.

Test signals

"3-terminal concept":

- If an input signal (\$A_INSE) is, for example, evaluated through **two channels**, the associated test output signal can be implemented using **one channel**. It is extremely important that the input signal can be forced/changed and checked in both channels.
- In the same way, the assigned test input signal for two-channel output signals (\$A_OUTSE) can be implemented in one channel if it is connected according to the following rule:
The test input signal may only return an "O.K." status ("1" signal level) if **both**

output signals function (i.e. both monitoring channels have output a "0"). A **simultaneous test** in both channels allows the correct functioning in both channels to be checked using **one** feedback signal.

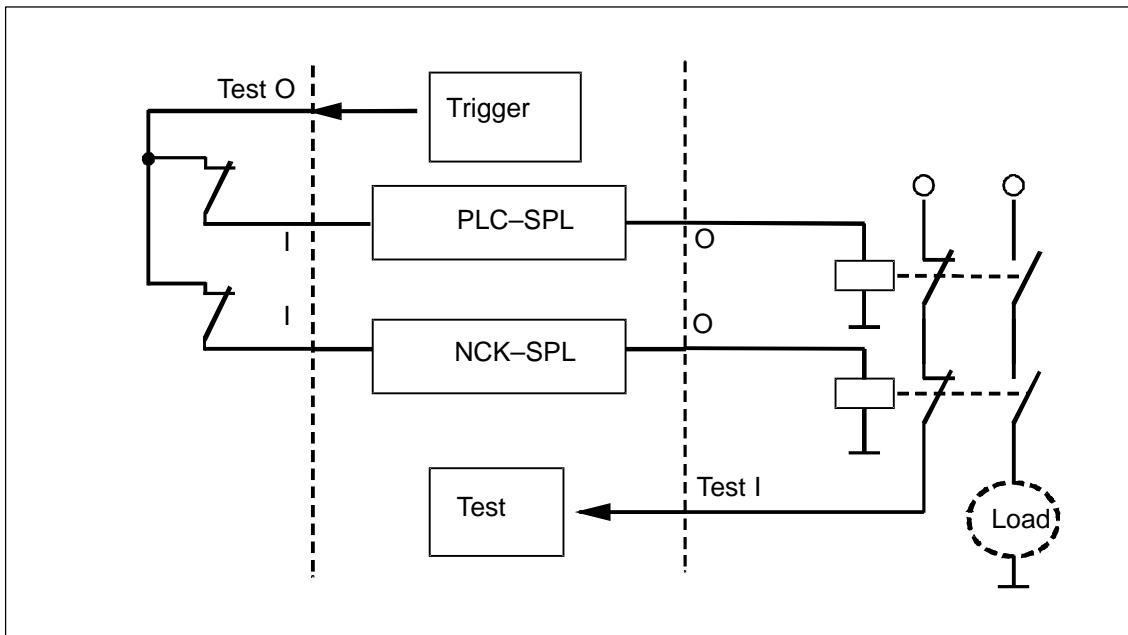

Fig. 5-36 3-terminal concept

Explanation of the diagram

- The forced checking procedure for the switch – evaluated through two channels – is triggered by setting the test output to "0". This simulates the actuation of the switch.
The NCK-SPL and PLC-SPL must respond to this signal change by setting their outputs to signal level "0".
- If at least one of the two channels responds in this way, then the load is disconnected from the power supply.
- Only if both channels respond in this way will the test input indicate that both channels are functioning correctly using a "1" signal. If this is not the case, there is a system fault and the test evaluation ("test" block) must prevent the power supply being reconnected to the load.

5.10 Safe programmable logic (SPL)

Trigger/test

The timer or event controlled triggering of the test stop is activated in one channel by the PLC. The function itself is separately executed in both channels.

Triggering and checking test signals for SPL input/output signals can also be completely executed through one channel in the PLC:

1. The PLC is optimized for these types of bit/logic operations and sequencing logic.
2. The program adapted to the machine is saved in the PLC user program when configuring/engineering and commissioning the machine.

If errors are detected, the PLC user program should respond by triggering an external "STOP D/E".

Notes to avoid errors

1. A "2-terminal concept" in which a **single-channel net (useful) signal** is to be subject to a forced checking procedure using a **single-channel** test signal is **not permitted**. In this case, the two-channel SPL structure would be worthless and crosswise data comparison would have no effect.

The following are permitted:

- A "full 4-terminal concept" (two-channel test signal for a two-channel useful [net] signal), or
 - The "3-terminal concept" recommended above, or
 - A "2-terminal concept *without* test signals", if the two-channel net (useful) signal to be tested automatically changes its level dynamically as a result of the process – and this can be verified using other net (useful) signals. In this case, the net (useful) signals assume the function of test signals. For example, a typical application could be a protective door evaluation function.
2. The signals "**external STOPs**" and "**test stop**" are processed internally in a special way:
 - In order to increase the level of security that a requested "external STOP" actually takes effect, the STOPs are internally exchanged between the two channels. Failure of the stop control function in **one** channel does **not** cause an error for these signals (in contrast to the mode changeover signals, e.g. "SG/SBH active") in the crosswise data comparison. While other signals can be subject to a forced checking procedure in parallel and in both channels (and should be – in order to avoid errors being triggered by the crosswise data comparison), the "external STOPs" and the "test stop" must be subject to a forced checking procedure **one after the other** in both channels. As an alternative, it is also possible to consider simultaneously subjecting the external STOPs to a forced checking procedure. However, in this case, it would be mandatory to use feedback signals through two channels.
 - The test stop itself may not be subject to a forced checking procedure in parallel in both channels because there is only **one** common hardware response and feedback signal "pulse cancellation" for both channels (the same as before).

Note

An application example for an "integrated EMERGENCY STOP" function is provided in Chapter 7 "Configuring example".

Note

An application example for a "door interlocking" function is provided in Chapter 7 "Configuring example".

Note

An application example for a test stop for SI level 2 is provided Chapter 7 "Configuring example".

5.11 SI I/Os using fail-safe modules connected to PROFIBUS-DP (from SW 6.3.30)

5.11.1 Description of functions

The fail-safe DP master (F master) integrated in the SINUMERIK 840D allows, in conjunction with fail-safe DP modules (F modules), fail-safe communications along PROFIBUS DP specified in accordance with the PROFIsafe profile (PROFIsafe communication).

This means that the safe-relevant input/output signals of the process (machine) can be coupled to the Safety Integrated function "safe programmable logic" (SPL) in the same way for both the PLC and NCK-SPL via PROFIBUS DP .

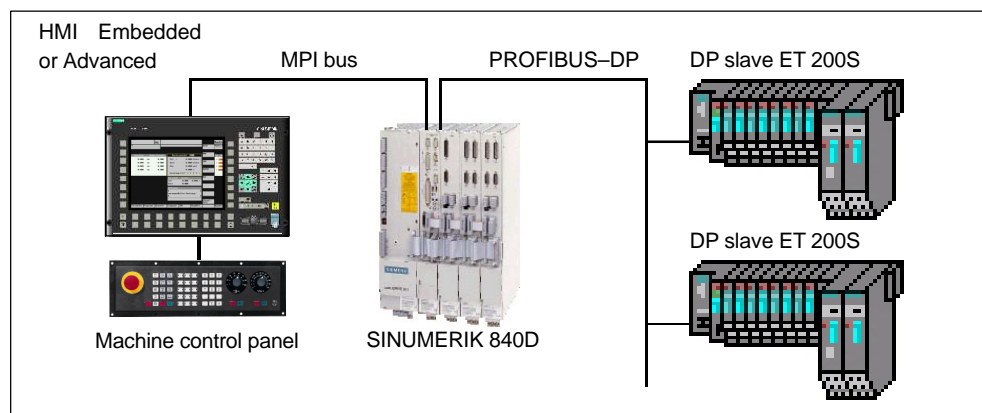

Fig. 5-37 SI I/Os using fail-safe modules connected to PROFIBUS-DP

Advantages

The benefits of this type of connection for safety-related I/O signals are:

- Fewer cables are required as a result of the distributed structure
- Unified PLC and NCK-SPL I/Os
- Unified safety-related and non-safety-related I/Os

PROFIBUS DP

PROFIBUS DP is an international, open fieldbus standard specified in the European fieldbus Standard EN 50170 Part 2. It is optimized for fast data transfer at the field level (time critical).

In the case of the components that communicate via PROFIBUS DP, a distinction is made between master and slave components.

5.11 SI I/Os using fail-safe modules connected to PROFIBUS-DP (from SW 6.3.30)

1. Master (active bus device)

Components operating on the bus as master determine the data exchange on the bus and are therefore also designated as active bus devices.

There are two classes of master:

- DP master, Class 1 (DPMC1):
Central master devices that exchange information with the slaves in fixed message (telegram) cycles.
Examples: S7-300 CPU's: CPU 315-2 DP, CPU 314-2F DP etc.
- DP master, class 2 (DPMC2):
Devices to configure, commission and for operator control and monitoring during bus operation.
Examples: Programming units, operator control and visualization devices

2. Slaves (passive devices)

These devices may only receive messages (telegrams), acknowledge them and transfer the message (telegram) to the master on its request.

Examples: Drives, I/O modules etc.

PROFIsafe

PROFIsafe is a PROFIBUS profile:

- PROFIsafe Profile for Safety Technology
Version 1.20, October 2002, Order No.: 3.092

For fail-safe data transfer between fail-safe components (F master and F slave) along PROFIBUS DP.

The PROFIsafe profile is characterized by the fact that the safety-related functions are implemented in safe terminal devices, i.e. the F/CPU's, the distributed slaves and the actuators/sensors/field devices using the standard PROFIBUS functions.

The useful (net) data of the safety function plus the safety measures are sent in a standard data telegram. This does not require any additional hardware components, since the protocol chips, drivers, repeaters, cables can still be used as they are. This means that both standard components and F components can be used on a PROFIBUS system.

5.11.2 System prerequisites

Hardware

The following hardware requirements must be fulfilled when setting-up PROFIsafe communications:

SIMATIC ET 200S

- Interface module
 - IM 151-1 High Feature

5.11 SI I/Os using fail-safe modules connected to PROFIBUS-DP (from SW 6.3.30)

- Power module
 - Power module PM-E F 24VDC PROFIsafe
 - Power module PM-D PROFIsafe
- F electronic modules
 - Digital electronics module 4/8 F-DI 24VDC PROFIsafe
 - Digital electronics module 4 F-DO 24VDC/2A PROFIsafe

Note

1. Standard power modules can be used to shut down fail-safe electronic modules. If standard electronic modules are to be safely shut down, fail-safe power modules must be used.
 2. Before mounting F modules, these must be configured and parameterized in STEP7, as STEP7 automatically assigns the PROFIsafe addresses of the F modules. The PROFIsafe address must then be set at each F module using DIL switches. This is only possible before mounting the F module.
-

(also refer to Chapter 3.5 "System prerequisites").

Software

The following software prerequisites must be fulfilled before PROFIsafe communications can be commissioned and used:

- SIMATIC
 - Generating and downloading the configuration
 - SIMATIC STEP 7, from Version V5.1 with Service Pack 6 and Distributed Safety Integrated V5.2
 - SIMATIC STEP 7 V5.2 and S7-F-Configuration Pack V5.3 (can be downloaded free of charge)
- SINUMERIK
 - Parameterization and cyclic PROFIsafe communications of the F master
 - Software release from SW 6.3.30
 - Software option "Distributed I/O via PROFIBUS-DP"
 - Software option "SINUMERIK Safety Integrated safety functions for the protection of personnel and machinery"

5.11.3 System structure

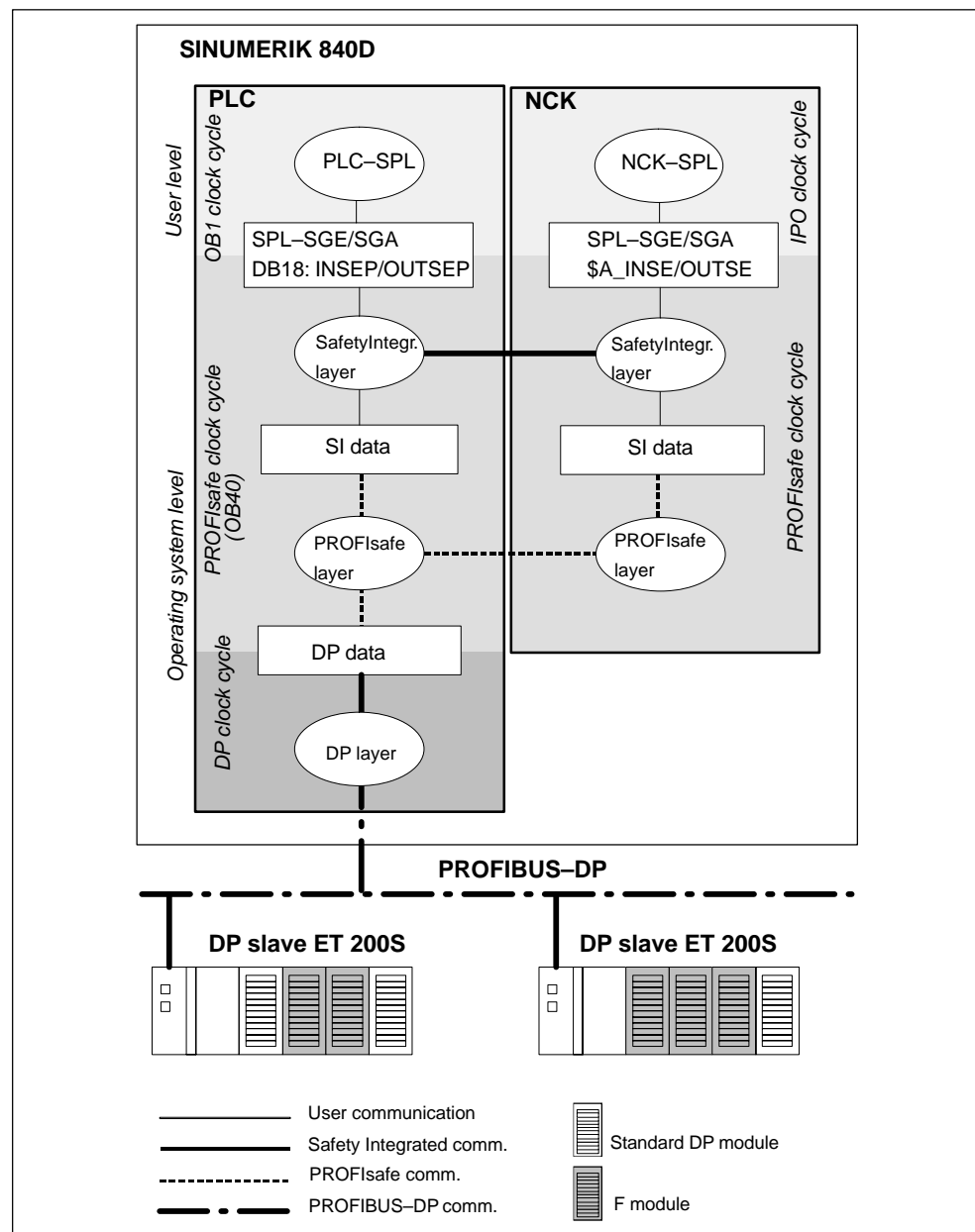

Fig. 5-38 System structure: SI I/O using F modules connected to PROFIBUS-DP

Just like Safety Integrated, the PROFIsafe system structure also has a 2-channel diverse system design based on the PLC and NCK-PROFIsafe layer.

PROFIsafe communication

The principle of PROFIsafe communications between SINUMERIK 840D and the F modules on the PROFIBUS DP is explained in detail below. This is based on the transfer of the SPL output data \$A_OUTSE/OUTSEP to the F-DO modules:

5.11 SI I/Os using fail-safe modules connected to PROFIBUS-DP (from SW 6.3.30)

The PROFIsafe layer creates a PROFIsafe telegram (F telegram) in each PROFIsafe cycle with the ANDed SPL output data as F useful (net) data

$$\text{F useful (net) data} = (\text{OUTSEP AND } \$A_OUTSE)$$

and the backup data (CRC and the consecutive number) and transfers it to the PROFIBUS layer via the DP data interface.

The PROFIBUS layer transfers a DP telegram with the PROFIsafe telegram created by the F layer in each PROFIBUS cycle as DP useful data to the DP slaves. This is independent of the PROFIsafe cycle. The F telegram is sent to the specific F-DO module via the backplane bus of the DP slave.

Configuring/parameterizing

The configuration and parameterization needed to connect the F modules to the external NCK/PLC-SPL interface comprises the following steps:

1. Create the configuration using SIMATIC STEP7. Refer to Chapter 5.11.4 "Configuring and parameterizing the ET 200S F I/O".
2. Perform a standard SINUMERIK 840D commissioning (minimum requirement).
3. Load the configuration and the PLC basic and user program modules into the SINUMERIK 840D PLC.
4. Parameterize the PROFIsafe-relevant SINUMERIK 840D machine data. refer to Chapter 5.11.5 "Parameterizing the F master (NCK)".

5.11.4 Configuring and parameterizing the ET 200S F I/O

The information on configuring and parameterizing the ET 200S F I/Os provided in this Chapter essentially refers to the specific requirements of SINUMERIK Safety Integrated. Detailed information on configuring and parameterizing the ET 200S and/or ET 200S F components is provided in the SIMATIC manuals:

Reference: SIMATIC Distributed I/O Device ET 200S, Manual
Order No.: 6ES7 151-1AA00-8AA0
SIMATIC Distributed I/O Device ET 200S Fail-Safe
Modules, Manual
Order Number: 6ES7 988-8FA11-8AA0

Configuring

The F I/O are configured while configuring the standard PROFIBUS configuration using STEP 7.

After the "S7 Distributed Safety" option package or the S7 F configuration package has been installed (refer to the Chapter 3.5 "System prerequisites") the F modules are available in the hardware catalog of STEP 7: HW Config. (if the hardware catalog is not displayed, open it using the menu command **View > Catalog**)

Profile: Standard > PROFIBUS DP > ET 200S

- Interface module
 - IM 151-xxx
- Electronics modules
 - IM 151-xxx > DI > 4/8 F-DI 24VDC
 - IM 151-xxx > DO > 4 F-DO 24VDC/2A
- F power module
 - IM 151-xxx > PM > PM-E F 24VDC/10A 2F-DO 24VDC/2A
- Standard power module
 - IM 151-xxx > PM > PM-E F 24VDC
- Motor starter
 - IM 151-xxx > Motor starter > PM > PM-D F PROFIsafe

Parameterization

Both the standard and F parameterization of the F modules is carried-out using the relevant properties dialog box of the module. Select the appropriate DP slave (IM 151-1) in the station window and then open the properties dialog box of the relevant F module in the detailed view.

Parameter: Input/output address

The input/output addresses that are assigned to an F module in the input/output address area of the DP master, are parameterized in the properties dialog box under:

Dialog box: Properties of the ET 200S standard module

Tab card: Addresses

Input: **Start**

Output: **Start**

Note

The input/output addresses of an F module are subject to the following conditions:

- Input address > 127
 - Output address = Input address.
-

F parameterization

F parameterization is carried out in the properties dialog box under:

Dialog box: Properties of the ET 200S standard module

Register: Parameters

Parameters > F parameters

The F parameters of the electronic modules are automatically set to the F monitoring time of the HW Config and cannot be changed.

The displayed values of the F parameters

- F_source_address
- F_target_address

must be entered into the machine data to parameterize the NCK in a subsequent parameterizing step.

F parameter: F_source_address

The F-source address is the decimal PROFIsafe address of the F master allocated automatically by HW Config.

Note

To clearly define the PROFIsafe communication, the PROFIsafe address of the F master – assigned by the HW Config – must be saved in the F master. To do this, the PROFIsafe address of the F master is entered into the machine data of the SINUMERIK 840D. Refer to Chapter 5.11.5 "Parameterizing the F master (NCK)".

F parameter: F_target_address

The F target address is the decimal PROFIsafe address of the F module allocated automatically by HW Config.

Note

In order to parameterize the PROFIsafe communication relationships, the F master is informed, via the PROFIsafe address of the F module that this F module is assigned to it. To do this, the PROFIsafe address is saved in the machine data of the F master (SINUMERIK 840D). Refer to Chapter 5.11.5 "Parameterizing the F master (NCK)".

F parameter: DIL switching setting

The DIL switch setting shown corresponds to the PROFIsafe address to be set on the DIL switch of the F module.

F parameter: F monitoring time

The F monitoring time defines the maximum time until a new valid F telegram must have been received from the F master.

Note

If the F monitoring time is configured to be shorter than the PROFIsafe monitoring clock cycle set using the appropriate machine data, when the control runs-up an alarm is displayed:

Alarm 27242 "PROFIsafe: F module %1, %2 incorrect"

Parameter: DO/DI channel x

The channels of an F module are parameterized in the properties dialog box under:

Dialog box: Properties of the ET 200S standard module

Tab card: Parameters

Parameters > Module parameter > DO or DI channel x

F-DI module

The channels of the F-DI module are mapped differently to the NCK/PLC-SPL inputs \$A_INSE/INSEP depending on the selected parameterization.

- 2v2 parameterization
For 2v2 parameterization, the process signals of both channels in the F-DI module are combined to form one F useful (net) data signal and thus supply an SPL input data.

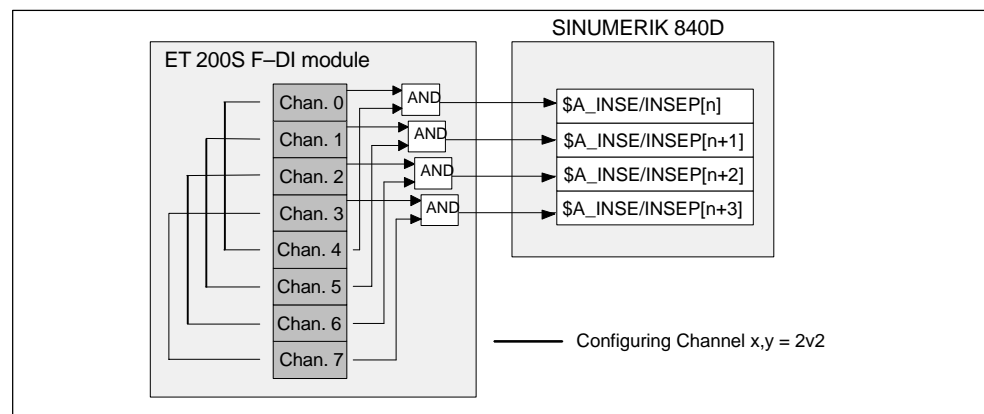

Fig. 5-39 2v2 mapping of the F-DI channels to SPL input data

5.11 SI I/Os using fail-safe modules connected to PROFIBUS-DP (from SW 6.3.30)

- 1v1 parameterization
For 1v1 parameterization, the process signals of both channels are transferred from the F-DI module and can thus supply 2 different SPL input data.

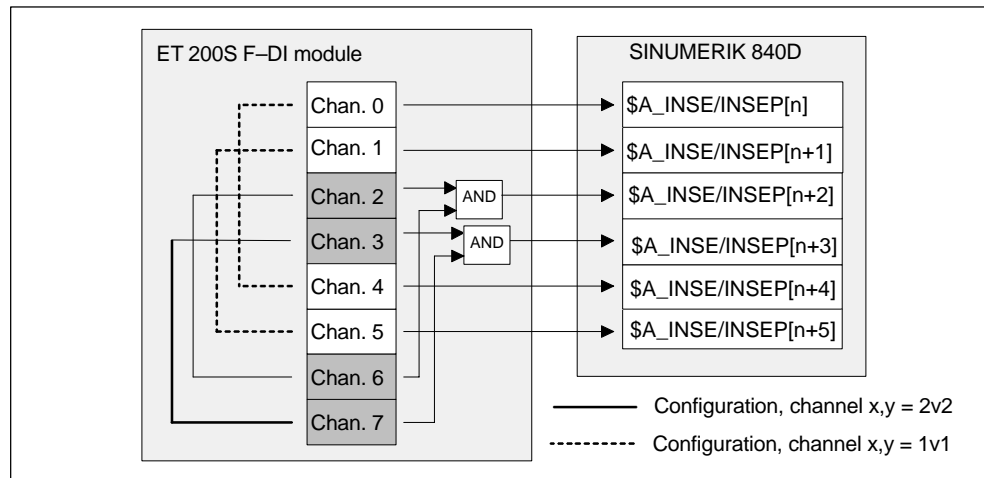

Fig. 5-40 2v2/1v1 mapping of the F-DI channels to SPL input data

Note

If mixed 2v2 and 1v1 parameterization is used in an F-DI module, this can reduce the number of SPL input data \$A_INSE/INSEP that can be used. This is the reason that we recommend that 1v1 is first parameterized followed by 2v2.

If more pieces of F net data of an F-DI module are used than the number relevant bits that can be transferred by parameterizing the channels of the F-DI module, then the control does not recognize this.

Example:

For a 2v2 parameterization of all of the channels of the F-DI module:

- ET 200S F, F-DI module: 4/8 F-DI 24 V DC

The 8 transferred F net data bits contain 4 relevant (bit 0 – bit 3) and 4 non-relevant bits (bit 4 – bit 7).

F-DO module

The NCK/PLC-SPL outputs \$A_OUTSE/OUTSEP are logically combined in the F driver to produce an F net (useful) data signal (implicit 2v2 parameterization) and mapped to the channels of the relevant F-DO module.

5.11 SI I/Os using fail-safe modules connected to PROFIBUS-DP (from SW 6.3.30)

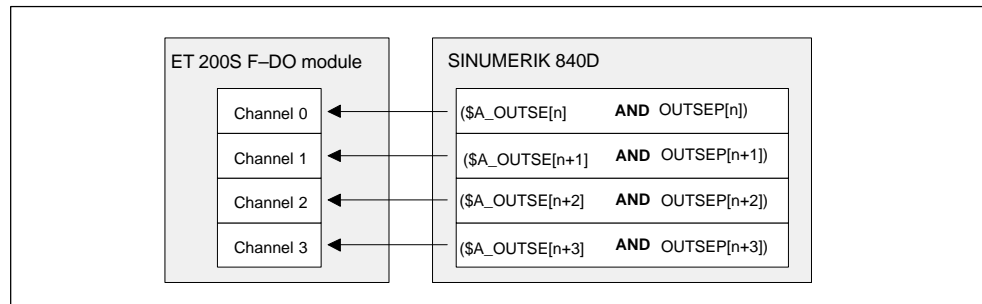

Fig. 5-41 Mapping the SPL output data to F-DO channels

PROFIsafe clock cycle and DP cycle time

When parameterizing the PROFIsafe clock cycle, in order to ensure a correct PROFIsafe communication, the DP cycle time, determined by HW Config must be observed (refer to Chapter 5.11.6 "Parameterizing the PROFIsafe communication (NCK)").

After the station has been fully configured, the DP cycle time can be determined by activating the equidistant (isochronous) bus cycle:

In HW Config, open the properties dialog box of the PROFIBUS: DP master of the configured station:

Dialog box: Properties – DP master system

Tab card: General

Subnetwork, button: Properties

Dialog box: Properties – PROFIBUS

Tab card: Network settings

Button: Options

Dialog box: Options

Tab card: Equidistance

Checkbox: **Activate equidistance bus cycle/
Re-calculate equidistant type**

(Note: Activate the equidistant bus cycle using the checkbox: "Activate equidistant bus cycle/re-calculate equidistant time".)

Display field: **Equidistant bus cycle**

(Note: The value calculated by HW Config and displayed in the display field: "Equidistant bus cycle" has the same significance as the DP cycle time)

Cancel

Cancel

Cancel

Note

The DP cycle time calculated by the HW Config is required as guideline to parameterize the PROFIsafe clock cycle (refer to Chapter 5.11.6 "Parameterizing the PROFIsafe communication (NCK)").

Before modifying the DP cycle time, read the information provided in the online documentation (Button: "Help" of the relevant dialog box).

5.11.5 Parameterizing the F master (NCK)

The F master is parameterized in the machine data of the NCK and comprises the following sub-areas:

- PROFIsafe communication
 - PROFIsafe address of the F master
 - PROFIsafe clock cycle
- SPL-SGE/SGA interface
 - PROFIsafe address of the F module
 - F net (useful) data filter (from SW 7.2)
 - SGE/SGA assignment

Refer to Chapter 5.11.6 "Parameterizing the PROFIsafe communication (NCK)".

SPL-SGE interface Refer to Chapter 5.11.8 "Parameterizing the SPL-SGE interface (NCK)".

SPL-SGA interface: Refer to Chapter 5.11.9 "Parameterizing the SPL-SGA interface (NCK)".

For reasons of transparency, the parameterization of the PROFIsafe communication, the SPL-SGE and SGA interface are described in the relevant dedicated chapters.

5.11.6 Parameterizing the PROFIsafe communication (NCK)

F master address

In order to define a unique and clear communication relationship between F slave and F master, in addition to the target address (PROFIsafe address of the F slave), the source address (PROFIsafe address of the F master) must be defined.

The PROFIsafe address of the F master is entered into the following machine data:

- MD10385: \$MN_PROFISAFE_MASTER_ADDRESS
(PROFIsafe address of the F master)

Input format: 0s 00 aaaa

5.11 SI I/Os using fail-safe modules connected to PROFIBUS-DP (from SW 6.3.30)

- s: Bus segment
Value range: 5 = DP connection on the PLC side
- aaaa: Hexadecimal PROFIsafe address
Value range: 1...FAD7_H

Note

The PROFIsafe address of the F master is provided under:

- HW Config > Properties dialog box of the F module > F parameter:
F_source_address
 - STEP7 V5.2 master address (standard value) = 2002
(from NCU system SW > = 6.4.15)
-

If the value entered does not match the value displayed in the F modules, an alarm is issued when the control runs-up:

- Alarm: 27220 "PROFIsafe: Number of NCK F modules (%1) <> Number of S7-F modules (%2)"

PROFIsafe clock cycle

The PROFIsafe clock cycle defines the time grid in which new F telegrams are generated by the F master for transfer to the F modules. The PROFIsafe clock cycle is derived as standard from the interpolation cycle in the ratio 1:1.

As part of the PROFIsafe communications, a cyclic interrupt of the PLC user program (OB1) in the PROFIsafe cycle is made via OB40.

Note

The OB40 run time increases by the following time for each F module.

- CPU 315-2 DP: approx. 0.5 ms
 - CPU 317-2 DP: approx. 0.25 ms
-

In order to reduce the possible resulting computational load, machine data:

- MD 10098: \$MN_PROFISAFE_IPO_TIME_RATIO
(factor, PROFIsafe communications clock cycle)

can be used to modify the ratio between the PROFIsafe and interpolation clock cycle.

In order to achieve a sufficiently fast response time regarding PROFIsafe-communications, the PROFIsafe clock cycle may not be parameterized greater than 25 ms. The selected PROFIsafe clock cycle is displayed in the machine data:

- MD 10099: \$MN_INFO_PROFISAFE_CYCLE_TIME,
(PROFIsafe, communications clock cycle)

5.11 SI I/Os using fail-safe modules connected to PROFIBUS-DP (from SW 6.3.30)

For a PROFIsafe clock cycle of greater than 25 ms, when the control runs-up the next time, an alarm is displayed:

- Alarm: 27200 "PROFIsafe cycle time %1 [ms] is too long"

PROFIsafe clock cycle and DP cycle time

The PROFIsafe clock cycle should be parameterized longer than the DP clock cycle time displayed by STEP 7: HW Config (refer to Chapter 5.11.4). Otherwise, the load (in time) on the PLC user program is increased as a result of unnecessary OB40 interrupts.

Note

The PROFIsafe clock cycle should be parameterized so that the following applies:
12 ms < PROFIsafe clock cycle < 25 ms

PROFIsafe clock cycle overruns

Even if the parameterized software operates error-free in normal operation, run time fluctuations in the PLC operating system (e.g. processing diagnostic alarms) can mean that the processing of the OB40 interrupt was not able to be completed before the start of the next PROFIsafe clock cycle.

In this particular case, the NCK attempts, up to a limit of 50 ms after the last correctly processed PROFIsafe clock cycle, to initiate an OB40 interrupt. The repeated attempts to initiate the OB40 interrupt are no longer executed in the PROFIsafe clock cycle but in the IPO clock cycle. Within this time, Alarm 27253: PROFIsafe: Communications error F master component %1 error %2 is not output.

After this 50 ms limit value is exceeded,

- Alarm: 27253 "PROFIsafe communications error F master components %1, error %2"

is displayed and the configured Stop response (Stop D or E) is output to the safety axes.

Further, an attempt is still made to initiate the OB40 interrupt and to maintain PROFIsafe communications.

The time up to initiating the next OB40 interrupt is displayed in the following NCK machine data:

- MD 10099: \$MN_INFO_PROFISAFE_CYCLE_TIME,
(PROFIsafe, communications clock cycle)

If the PROFIsafe clock cycle is continuously exceeded and just not sporadically, then the following alarm is displayed:

- Alarm: 27256 "PROFIsafe actual cycle time %1 [ms] > parameterized cycle time"

5.11.7 Parameterizing the SPL-SGE/SGA interface (up to SW 7.1)

Assignment: F modules to the F master

The NCK machine data is used to parameterize the F master regarding the F modules assigned to it:

- MD 10386: \$MN_PROFISAFE_IN_ADRESS[Index],
(PROFIsafe address of an input module)
- MD 10387: \$MN_PROFISAFE_OUT_ADDRESS[Index],
(PROFIsafe address of an output module)

Index: 0...15

Input format: 0s 00 0a aa

- s: Bus segment (currently, only: 5 = DP connection on the PLC side)
- aaa: Hexadecimal PROFIsafe address of the F module

The PROFIsafe address of the F module is the value of the F parameter defined by HW Config: F_target_address (refer below: assignment example).

Note

The PROFIsafe address of an F module can be found under:

HW Config > Properties dialog box of the F module ->

F parameter: F_target_address (e.g.: **1022_D = 3FE_H**)

Refer to Chapter 5.11.4

The PROFIsafe address of the F modules, displayed in a decimal notation in HW Config, should be entered into the NCK machine data in the hexadecimal format:

MD 10386: \$MN_PROFISAFE_IN_ADRESS[Index]

MD 10387: \$MN_PROFISAFE_OUT_ADDRESS[Index]

Assignment example

Assignment example using two ET 200S F-DI modules "4/8 F-DI 24V":

- HW Config has assigned the F target addresses to the F-DI modules: 1022 and 1021.
- For the parameter: "Evaluation of the encoder, "2v2" was selected so that only bits 0 to 3 are used to transfer relevant data in the F net (useful) data. A 0 is always entered in the remaining F net (useful) data.

In the NCK machine data:

MD 10386: \$MN_PROFISAFE_IN_ADRESS[0] and [1]

the F target addresses (1022 and 1021) of the configured F-DI modules are entered.

Using the NCK machine data:

MD 10388: \$MN_PROFISAFE_IN_ASSIGN[0] and [1]

5.11 SI I/Os using fail-safe modules connected to PROFIBUS-DP (from SW 6.3.30)

F net (useful) data is assigned:

F net data from 1022, bit 0 to bit 3 to SPL-SGE[1] to SPL-SGE[4]

F net data from 1021, bit 0 to bit 3 to SPL-SGE[5] to SPL-SGE[8]

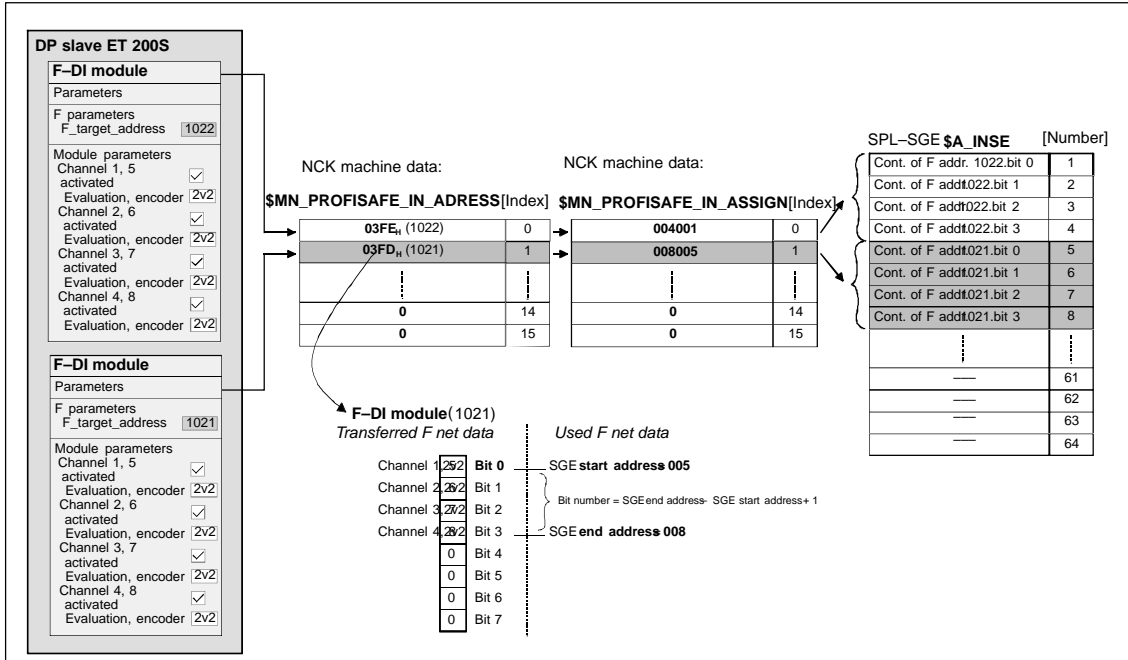

Fig. 5-42 Assignment example: F net data to SPL-SGEs

5.11.8 Parameterizing the SPL-SGE interface (NCK) (from SW 7.2)

Note

The examples, now listed, to parameterize the SPL-SGE interface are based on the following specifications:

F-DI module

- F address: 114 = 90H
- F net data length: 8 bytes

Machine data

- MD10386 \$MN_PROFISAFE_IN_ADDRESS[5] = 05 00 0090
- MD13300 \$MN_PROFISAFE_IN_FILTER[5] = 000F 000F
- MD10388 \$MN_PROFISAFE_IN_ASSIGN[5] = 008 001

Assignment: F module to the F master

Important

Currently, only sub-slot [0] may be used.

F net data of an F-DI module is sub-divided into units each 32 bits. Each of these 32 bit units are known as sub-slots. This sub-division, for assigning the F-DI module to the F master is expressed in the sub-slot address.

The machine data is used to assign the F-DI module to the F master:

- MD 10386: \$MN_PROFISAFE_IN_ADDRESS[Index],
(PROFIsafe address of the F-DI module)

Input format: 0s 0x aaaa

- s: Bus segment
Value range: 5 = DP connection on the PLC side
- x: Sub-slot address
Value range: 0...1
x = 0 addresses the F net data signals 1...32
x = 1 addresses the F net data signals 33...64
- aaaa: Hexadecimal PROFIsafe address of the F module
Value range: 1...FFFF_H

Note

The PROFIsafe address of an F module is provided in STEP7 HW Config under:

Properties dialog box of the F module > F parameters: F_target_address

The PROFIsafe address of the F module is displayed in the decimal format in HW Config but must be entered into the machine data in the hexadecimal format.

Example

Net data of the 1st sub-slot is used to supply the SPL-SGE of the F-DI module with the PROFIsafe address: 90H.

5.11 SI I/Os using fail-safe modules connected to PROFIBUS-DP (from SW 6.3.30)

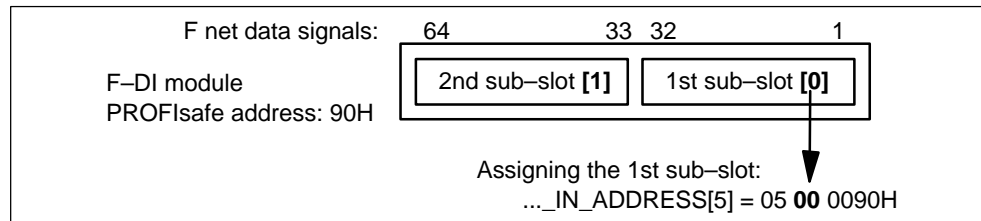

Fig. 5-43 F-DI addressing with the sub-slot

As a result of the possibility of flexibly assigning the F net data of an F-DI module to the SPL-SGE by combining the machine data now described (...IN_FILTER[n] and ...IN_ASSIGN[n]), it is possible and also makes sense to use the same PROFIsafe and sub-slot address a multiple number of times within the machine data:

- \$MN_PROFISAFE_IN_ADDRESS[0...max. Index]

Note

All machine data to connect an F-DI module to the SPL-SGE are associated with one another through the common index of the machine data:

- \$MN_PROFISAFE_IN_ADDRESS[Index]
 - \$MN_PROFISAFE_IN_FILTER[Index]
 - \$MN_PROFISAFE_IN_ASSIGN[Index]
-

F net data filter

If not all of the F net data signals of the sub-slots of an F-DI module are required for further processing within the SPL, then the relevant F-net data signal signals can be selected using the F-net data filter. Only these are then transferred to the SPL-SGE.

The F net data filter is parameterized in the machine data:

- MD 13300: \$MN_PROFISAFE_IN_FILTER[Index] (F net data filter IN)

Each F net data signal of the sub-slot is assigned to a filter bit. The filter bits of the F net data signals, that are to be transferred to SPL-SGE, should be set to 1. The filter bits of the F net data signals, that are not to be transferred, should be set to 0. The selected F net data signals are always transferred to the SPL-SGE as a consecutive bit field (i.e. a bit field without any gaps).

FFFF FFFFH is the default setting of the filter. This means that all F net data signals are transferred.

Example

8 F net data signals (bits 0...3 and bits 16...19) of the 1st sub-slot are filtered from the F net data of the F-DI module and transferred to the SPL-SGE.

5.11 SI I/Os using fail-safe modules connected to PROFIBUS-DP (from SW 6.3.30)

- MD10386 \$MN_PROFISAFE_IN_ADDRESS[5] = 05 00 0090
- **MD13300 \$MN_PROFISAFE_IN_FILTER[5] = 000F 000F**
- MD10388 \$MN_PROFISAFE_IN_ASSIGN[5] = 008 001

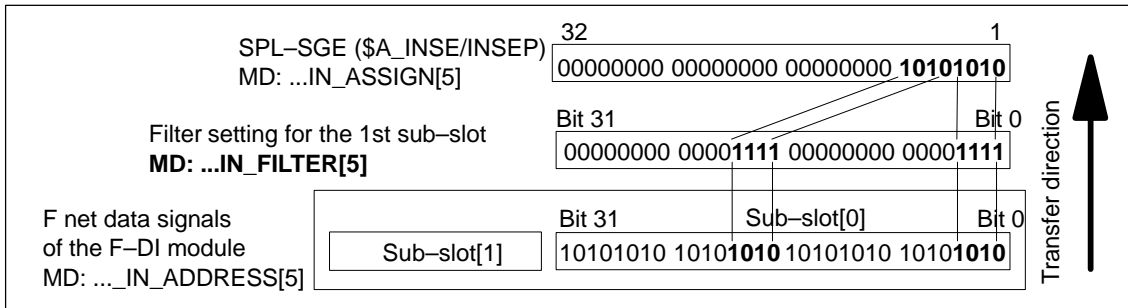

Fig. 5-44 Filtering the F net data signals in the input direction

SPL-SGE assignment

With this assignment, it is defined in which SPL-SGE (\$A_INSE/INSEP) the seamless (without gaps) F net data selected using the F net data filter are transferred.

The assignment is made using machine data:

- MD 10388: \$MN_PROFISAFE_IN_ASSIGN[Index],
(input assignment: F net data signals to \$A_INSE)

Input format: 00 aaa bbb

- aaa: Most significant SPL-SGE \$A_INSE/INSEP[aaa]
- bbb: Least significant SPL-SGE \$A_INSE/INSEP[bbb]

Example

8 F net data signals of the 1st sub-slot filtered from the F net data of the F-DI module are transferred in the SPL-SGE from \$A_INSE[1]/INSEP[1].

- MD10386 \$MN_PROFISAFE_IN_ADDRESS[5] = 05 00 0090
- MD13300 \$MN_PROFISAFE_IN_FILTER[5] = 000F 000F
- **MD10388 \$MN_PROFISAFE_IN_ASSIGN[5] = 008 001**

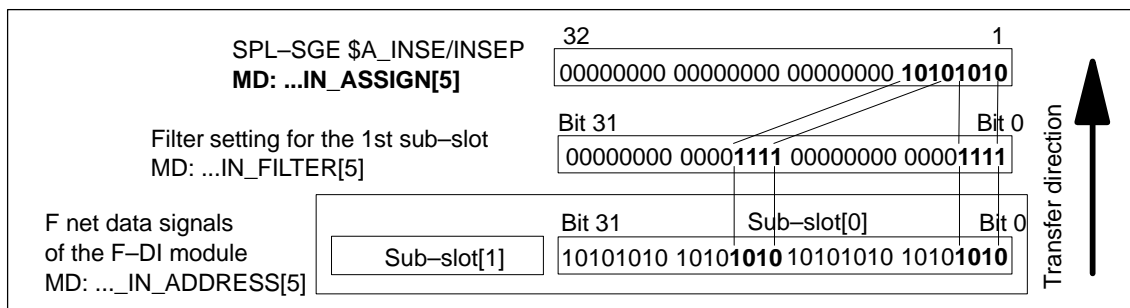

Fig. 5-45 Transfer: Filtered F net data signals in SPL-SGE

5.11.9 Parameterizing the SPL-SGA interface (NCK) (from SW 7.2)

Note

The following examples show the parameterization of the SPL-SGA interface based on the following specifications:

F-DO module

- F address: 256 = 100H
- F net data length: 6 bytes

Machine data

- MD10387 \$MN_PROFISAFE_OUT_ADDRESS[3] = 05 01 0100
 - MD13301 \$MN_PROFISAFE_OUT_FILTER[3] = 0000 1031
 - MD10389 \$MN_PROFISAFE_OUT_ASSIGN[3] = 008 005
-

Assignment: F module to the F master

The F net data of an F-DO module are sub-divided into 32-bit units. Each of these 32 bit units are known as sub-slots. This sub-division, for assigning the F-DO module to the F master is expressed in the sub-slot address.

The machine data is used to assign the F-DO module to the F master:

- MD 10387: \$MN_PROFISAFE_OUT_ADDRESS[Index],
(PROFIsafe address of the F-DI module)
Input format: 0s 0x aaaa
 - s: Bus segment
Value range: 5 = DP connection on the PLC side
 - x: Sub-slot address
Value range: 0...1
x = 0 addresses the F net data signals 1...32
x = 1 addresses the F net data signals 33...64
 - aaaa: Hexadecimal PROFIsafe address of the F module
Value range: 1...FFFF_H

Note

The PROFIsafe address of an F module is provided in STEP7 HW Config under:

Properties dialog box of the F module > F parameters: F_target_address

The PROFIsafe address of the F module is displayed in the decimal format in HW Config but must be entered into the machine data in the hexadecimal format.

Example

SPL-SGA are written – as F net data – into the 2nd sub-slot of the F-DO module with PROFIsafe address: 100H.

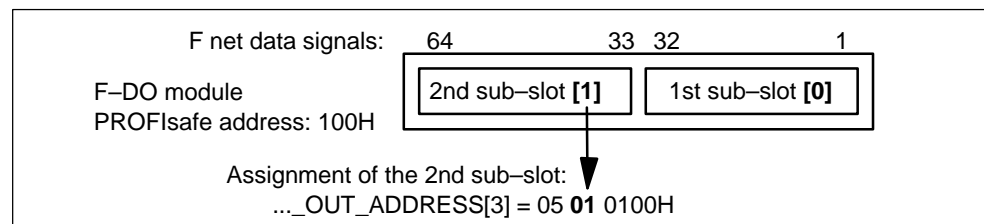

Fig. 5-46 F-DO addressing with sub-slot

As a result of the possibility of flexibly assigning the F net data of an F-DO module to the SPL-SGA by combining the machine data now described (...OUT_FILTER[n] and ...OUT_ASSIGN[n]), it is possible and also makes sense to use the same PROFIsafe and sub-slot address a multiple number of times within the machine data:

- \$MN_PROFISAFE_OUT_ADDRESS[0...max. Index]

Note

All machine data to connect an F-DO module to the SPL-SGA are associated with one another through the common index of the machine data:

- \$MN_PROFISAFE_OUT_ADDRESS[Index]
- \$MN_PROFISAFE_OUT_FILTER[Index]
- \$MN_PROFISAFE_OUT_ASSIGN[Index]

F net data filter

The F net data filter allows the selected SPL-SGA – without any gaps – to be distributed across any F net data signals within the sub-slot.

The F net data filter is parameterized in the machine data:

- MD 13301: \$MN_PROFISAFE_OUT_FILTER[Index] (F net data filter OUT)

Every selected SPL-SGA is assigned a filter bit in an increasing sequence. The filter bits, which are used to transfer the SPL-SGA to the F net data signals, should be set to 1. The filter bits of the SPL-SGA that are not to be transferred, should be set to 0.

FFFF FFFFH is the default setting of the F net data filter; this means that all of the selected SPL-SGA, are transferred from F net data signal 1 onwards (bit 0) into the F net data of the F-DO module.

Example

4 SPL-SGA are transferred into the F net data of the 2nd sub-slot of the F-DO module corresponding to the set filter bits:

- MD10386 \$MN_PROFISAFE_OUT_ADDRESS[3] = 05 01 0100
- **MD13301 \$MN_PROFISAFE_OUT_FILTER[3] = 0000 1031**

5.11 SI I/Os using fail-safe modules connected to PROFIBUS-DP (from SW 6.3.30)

- MD10389 \$MN_PROFISAFE_OUT_ASSIGN[3] = 008 005

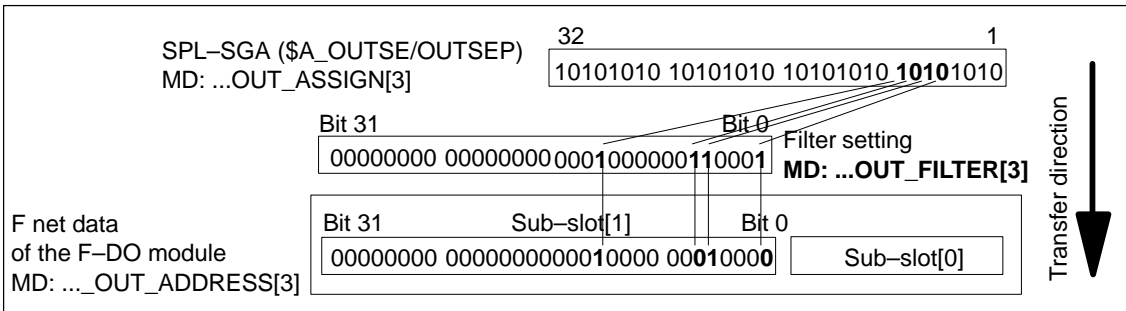

Fig. 5-47 Filtering the SPL-SGA in the output direction

SPL-SGA assignment

The assignment defines which SPL-SGA (\$A_OUTSE/OUTSEP) are transferred in the F net data of the F-DO module. The SPL-SGA can only be specified as a field of output signals without any gaps (consecutive field of output signals).

The assignment is made using machine data:

- MD 10389: \$MN_PROFISAFE_OUT_ASSIGN[Index],
(Output assignment: SPL-SGA to F net data signals)
Input format: 00 aaa bbb
 - aaa: Most significant SPL-SGA \$A_OUTSE/OUTSEP[aaa]
 - bbb: Least significant SPL-SGA \$A_OUTSE/OUTSEP[bbb]

Example

From the SPL-SGA, 4 output signals \$A_OUTSE/OUTSEP[5] to \$A_OUTSE/OUTSEP[8] are selected for transfer in the F net data of the F-DO module:

- MD10386 \$MN_PROFISAFE_OUT_ADDRESS[3] = 05 01 0100
- MD13301 \$MN_PROFISAFE_OUT_FILTER[3] = 0000 1031
- **MD10389 \$MN_PROFISAFE_OUT_ASSIGN[3] = 008 005**

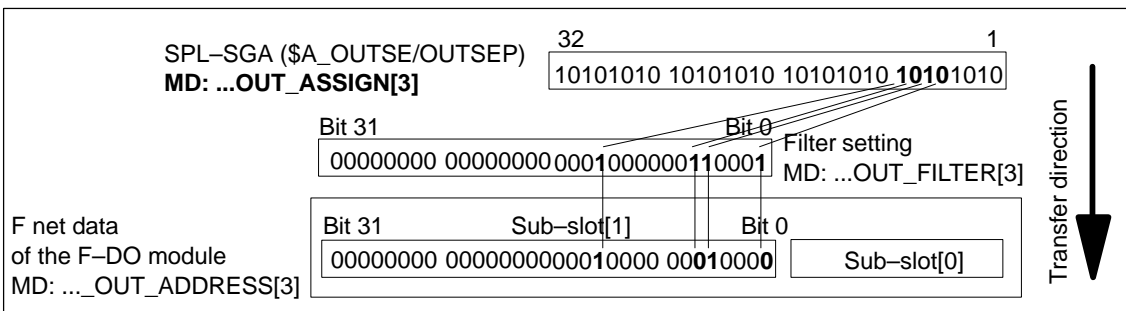

Fig. 5-48 Selecting the SPL-SGA for filtering

5.11.10 Module type (NCK)

The F module type cannot be explicitly specified. The F master determines the type depending on the machine data in which a PROFIsafe address has been entered:

- \$MN_PROFISAFE_IN_ADDRESS
- \$MN_PROFISAFE_OUT_ADDRESS

Dependent on this, the F module is identified as either input, output or bidirectional I/O modules.

Table 5-54 F module types

..._IN_ADDRESS	..._OUT_ADDRESS	Type
F address	–	Input module
–	F address	Output module
F address	F address	Input/output module

5.11.11 Axial checksum (NCK)

The following machine data:

- MD 10098: \$MN_PROFISAFE_IPO_TIME_RATIO
- MD 10385: \$MN_PROFISAFE_MASTER_ADDRESS
- MD 10386: \$MN_PROFISAFE_IN_ADDRESS
- MD 10387: \$MN_PROFISAFE_OUT_ADDRESS
- MD 10388: \$MN_PROFISAFE_IN_ASSIGN
- MD 10389: \$MN_PROFISAFE_OUT_ASSIGN
- MD 13300: \$MN_PROFISAFE_IN_FILTER (from SW 7.2)
- MD 13301: \$MN_PROFISAFE_OUT_FILTER (from SW 7.2)

are calculated into the axial checksum machine data:

- MD 36998: \$MA_SAFE_ACT_CHECKSUM[0] (actual checksum)

Changes only become active after they are acknowledged on an axis-for-axis basis:

SINUMERIK HMI Advanced or HMI Embedded:

Operator area changeover > Commissioning > Drive configuration > softkey "Acknowledge SI data"

If machine data is modified without being acknowledged, the next time the control runs-up, an alarm is displayed:

- Alarm: 27032 "Axis %1 Checksum error safe monitoring. Acknowledgment and an acceptance test are required!"

5.11.12 Parameterizing the F master (PLC)

In the PLC, the F master does not have to be explicitly parameterized regarding the connection of F modules.

The PLC is parameterized explicitly as follows:

- Parameterizing the NCK
- Generating and downloading the configuration

Data block DB18

The DB18 data block has been expanded by two read-only bit arrays:

- INSEP_PROFISAFE
- OUTSEP_PROFISAFE

The two bit arrays are used to display which INSEP/OUTSEP bytes are only assigned to F modules as a result of the parameterization in the NCK machine data:

- MD 10388: \$MN_PROFISAFE_IN_ASSIGN
- MD 10389: \$MN_PROFISAFE_OUT_ASSIGN

Data block DB18 (excerpt):

```
STRUCT
:
  SPL_DATA:STRUCT
    INSEP:          ARRAY[1 ... 64] OF BOOL;
    OUTSEP:         ARRAY[1 ... 64] OF BOOL;
:
  //external SPL-Inputbytes (HW) with PROFIsafe Slaves
  INSEP_PROFISAFE: ARRAY[1 ... 8] OF BOOL;
  //external SPL-Outputbytes (HW) with PROFIsafe Slaves
  OUTSEP_PROFISAFE: ARRAY[1 ... 8] OF BOOL;
:
END_STRUCT;
```

5.11.13 Response times

The response times listed here refer exclusively to the internal processing of the signals by the F master. This means the following:

- **T(FDI → DB18) or T(FDI → SPL-INSE)**
The transfer time from the input area of the F-DI module to the input interface of the PLC-SPL or NCK-SPL
- **T(DB18 → FDO) or T(SPL-OUTSE → FDO)**
The transfer time from the output interface of the PLC-SPL or NCK-SPL to the output area of the F-DO module.

5.11 SI I/Os using fail-safe modules connected to PROFIBUS-DP (from SW 6.3.30)

- **T(FDI → FDO)**

Sum of the transfer times from:

- T(FDI → DB18) or T(FDI → SPL-INSE)
- Processing time by the user-specific SPL program.
- T(DB18 → FDO) or T(SPL-OUTSE → FDO)

The following applies for the subsequent tables of the PLC and NCK processing times:

- Values in *italics* can increase by up to 50 ms due to delays in the communication path between the NCK and PLC.
- PST = 50 ms (PST = PROFIsafe clock cycle) is the permanently implemented maximum time to detect error-free communications between the NCK and PLC. A STOP response (STOP D/E) is initiated if this time is exceeded.
- OB1 = 150 ms is the maximum time set as standard in the PLC-CPU to monitor the user level. The PLC goes into the STOP state if this time is exceeded.
- 0...m * IPO: This time component only becomes applicable if delays are incurred on the PLC side. In this case, in each subsequent IPO clock cycle, it is determined as to whether the PLC is ready to communicate again.
- OB40_INT is the maximum permissible time to initiate the interrupt on the NCK side up to execution of the PROFIsafe software and a ready signal to the NCK. The time is mainly determined by the run time (propagation time) of the F driver implementation on the PLC side and the PLC user program to be run-through in the OB40 context. These times typically lie in the vicinity of a few milliseconds.
- The specified maximum times are theoretical values; it is extremely improbable that they actually occur in practice.

Reason for this:

- It is improbable that the run time of the PLC-F driver is delayed – in the OB40 context – by the maximum time of 50 ms. The reason for this is that the interrupting organizational blocks (OB8x) only have such long run times in extremely few cases.
- For the theoretical value, it would be necessary that two consecutive runs of the PLC-PROFIsafe master driver in the OB40 context are delayed by the permitted maximum of 50 ms – this is extremely improbable.
- The maximum time of 150 ms for the user program is not reached in any of the applications relevant in practice.

PLC processing times

Time:: T(FDI→DB18)		
Formula	$2 * PST + 1 * OB1$	
Max. times	$2 * 50 \text{ ms} + 1 * 150 \text{ ms}$	250 ms
Typical times ¹⁾	$2 * 16 \text{ ms} + 1 * 30 \text{ ms}$	62 ms
Time:: T(DB18→FDO)		
Formula	$2 * PST + 1 * OB1$	
Max. times	$2 * 50 \text{ ms} + 1 * 150 \text{ ms}$	250 ms

5.11 SI I/Os using fail-safe modules connected to PROFIBUS-DP (from SW 6.3.30)

Time:: T(DB18->FDO)		
Typical times ¹⁾	2 * 16 ms + 1 * 30 ms	62 ms
Time:: T(FDI->FDO)		
Formula	4 * PST + 2 * OB1	
Max. times	4 * 50 ms + 2 * 150 ms	500 ms
Typical times ¹⁾	4 * 16 ms + 2 * 30 ms	124 ms

1) Typical times: PST = 16ms; OB1 = 30ms

NCK processing times: $PST \leq 2 * IPO$

Time:: T(FDI->SPL-INSE)		
Formula	2 * PST + 1 * IPO	
Max. times	2 * 50 ms + 25 ms	125 ms
Typical times ¹⁾	2 * 16 ms + 8 ms	40 ms
Time:: T(SPL-OUTSE->FDO)		
Formula	IPO + 0...m * IPO + OB40_INT	
Max. times	25 ms + 50 ms + 50 ms	125 ms
Typical times ¹⁾	8 ms + 2 ms	10 ms
Time:: T(FDI->FDO)		
Formula	2 * PST + 2 * IPO + 0...m * IPO + OB40_INT	
Max. times	100 ms + 50 ms + 50 ms + 50 ms	250 ms
Typical times ¹⁾	2 * 16 ms + 2 * 8 ms + 2 ms	50 ms

1) Typical times: PST = 16ms; IPO = 8ms; OB40_INT = 2ms

NCK processing times: $PST > 2 * IPO$

Time:: T(FDI->SPL-INSE)		
Formula	2 * PST + 1 * IPO	
Max. times	2 * 48 ms + 8 ms	104 ms ²⁾
Typical times ¹⁾	2 * 18 ms + 6 ms	42 ms
Time:: T(SPL-OUTSE->FDO)		
Formula	IPO + (n-2) * IPO + 0...m * IPO + OB40_INT	
Max. times	16 ms + 48 ms + 48 ms	112 ms ²⁾
Typical times ¹⁾	6 ms + 6 ms + 2 ms	14 ms
Time:: T(FDI->FDO)		
Formula	2 * PST + PST + 0...m * IPO + OB40_INT	

5.11 SI I/Os using fail-safe modules connected to PROFIBUS-DP (from SW 6.3.30)

Time:: T(FDI->FDO)		
Max. times	100 ms + 25 ms + 50 ms + 50 ms	225 ms ³⁾
Typical times ¹⁾	2 * 18 ms + 18 ms + 2 ms	56 ms

with:

PST: PROFIsafe clock cycle

PST = n * IPO; with n = 1, 2, 3, ...

1. Typical times: PST = 18 ms; IPO = 6 ms; OB40_INT = 2 ms
2. This time is valid for the case: IPO = 8 ms, n=3 => PST = 24 ms;
(maximum times for values n > 2)
3. This time is valid for the case: PST = n * IPO = 25 ms

5.11.14 Functional limitations

Mixed mode for I/O modules

I/O modules available for SINUMERIK 840D

- F modules
- DMP modules
- Onboard I/O

can be operated in parallel.

Multiple assignment of inputs/outputs of the various modules to the same SPL
SGE/SGA are also detected and displayed using an alarm:

- Alarm: 27204 "PROFIsafe: Dual allocation MD %1 [%2] –MD %3 [%4]"

F modules

As far as the F modules that can be operated with a SINUMERIK 840D, the following limitations apply:

- F modules with dynamic i parameters are not supported
- The maximum possible F net data width for each F module is 64 bits.
- The value range for the F address of an F module is as follows: 1 – 65535_D or 1 – FFFF_H

Axial NCK-SGE/SGA

The I/O (F net data) of an F module cannot be connected to axial NCK-SGE/SGA. They can only be connected in the context of the NCK-SPL that must be installed for the purpose.

PLC SPL SGE/SGA

The basic PLC program automatically connects the I/O (F net data) of an F module to the SPL interface in data block DB18.

It is not possible to connect them in a PLC user program.

Axial 611D SGE/SGA

I/O (F net data) of an F module cannot be connected to axial 611D-SGE/SGA.

They can only be connected in the context of the PLC-SPL that must be installed for the purpose.

Data Description

Note

The function "safe software limit switch" (SE) is also called "safe limit positions" and the function "safe software cams" (SN) is also called "safe cams".

6.1 Machine data for SINUMERIK 840D

6.1.1 Overview of the machine data

Note

The meaning of the symbols used in the table is as follows:

- This data is calculated into SAFE_ACT_CHECKSUM[0].
 - This data is calculated into SAFE_ACT_CHECKSUM[1].
 - This data is not calculated into any checksum.
-

Table 6-1 Overview of machine data for SINUMERIK 840D

No.	Identifier	Name	Checksum MD
General (\$MN_...)			
10050	SYSCLOCK_CYCLE_TIME	Basic system clock cycle, refer to /FBD/, G2	●
10060	POSCTRL_SYSCLOCK_TIME_RATIO	Factor for position control clock cycle, refer to /FBD/, G2	—
10070	IPO_SYSCLOCK_CYCLE_TIME_RATIO	Factor, interpolator clock cycle	●
10089	SAFE_PULSE_DIS_TIME_BUS_FAIL	Delay time, pulse cancellation on drive failure	●
10090	SAFETY_SYSCLOCK_TIME_RATIO	Factor for the monitoring clock cycle	—
10091	INFO_SAFETY_CYCLE_TIME	Displays the monitoring clock cycle	—
10092	INFO_CROSSCHECK_CYCLE_TIME	Displays the clock cycle time for a crosswise data comparison	—

6.1 Machine data for SINUMERIK 840D

Table 6-1 Overview of machine data for SINUMERIK 840D

No.	Identifier	Name	Checksum MD
10093	INFO_NUM_SAFE_FILE_ACCESS	Number of SPL file access operations	—
10094	SAFE_ALARM_SUPPRESS_LEVEL	Alarm suppression level	—
10095	SAFE_MODE_MASK	Safety Integrated modes	—
10096	SAFE_DIAGNOSIS_MASK	Safety Integrated diagnostics function	—
10097	SAFE_SPL_STOP_MODE	Stop response for SPL errors	●
10098	PROFISAFE_IPO_TIME_RATIO	Factor PROFIsafe communications clock cycle time	●
10099	INFO_PROFISAFE_CYCLE_TIME	PROFIsafe communications clock cycle time	—
10200	INT_INCR_PER_MM	Computational resolution for linear positions, refer to /FBD/, G2	—
10210	INT_INCR_PER_DEG	Computational resolution for angular positions, refer to /FBD/, G2	—
10366	HW_ASSIGN_DIG_FASTIN	Hardware assignment of external digital NCK inputs, refer to /FBD/, A4	—
10368	HW_ASSIGN_DIG_FASTOUT	Hardware assignment of external digital NCK outputs, refer to /FBD/, A4	—
10385	PROFISAFE_MASTER_ADRESS	PROFIsafe address of the PROFIsafe master module	●
10386	PROFISAFE_IN_ADRESS	PROFIsafe address of an Input module	●
10387	PROFISAFE_OUT_ADRESS	PROFIsafe address of an PROFIsafe output module	●
10388	PROFISAFE_IN_ASSIGN	Input assignment \$A_INSE to PROFIsafe input module	●
10389	PROFISAFE_OUT_ASSIGN	Output assignment \$A_OUTSE to PROFIsafe module	●
10390	SAFE_IN_HW_ASSIGN	Input assignment, ext. interface SPL	●
10392	SAFE_OUT_HW_ASSIGN	Output assignment, ext. interface SPL	●
13010	DRIVE_LOGIC_NR	Logical drive number, refer to /FBD/, G2	—
13300	PROFISAFE_IN_FILTER	F useful (net) data filter IN	●
13301	PROFISAFE_OUT_FILTER	F net (useful) data filter OUT	●
Axis-/spindle-specific (\$MA_ ...)			
30240	ENC_TYPE	Encoder type, type of actual value sensing (position actual value), refer to /FBD/, G2	—
30300	IS_ROT_AX	Rotary axis/spindle, refer to /FBD/, R2	—
30320	DISPLAY_IS_MODULO	Modulo 360 degrees, display for rotary axis or spindle, refer to /FBD/, R2	—
30330	MODULO_RANGE	Size of the modulo range, refer to /FBD/, R2	—
32300	MA_AX_ACCEL	Axis acceleration, refer to /FBD/, B2	—
35200	GEAR_STEP_SPEEDCTRL_ACCEL	Acceleration in the open-loop speed controlled mode, refer to /FBD/, S1	—
35210	GEAR_STEP_POSCTRL_ACCEL	Acceleration in the closed-loop position controlled mode, refer to /FBD/, S1	—

6.1 Machine data for SINUMERIK 840D

Table 6-1 Overview of machine data for SINUMERIK 840D

No.	Identifier	Name	Checksum MD
35410	SPIND_OSCILL_ACCEL	Acceleration when oscillating, refer to /FBD/, S1	—
36060	STANDSTILL_VELO_TOL	Threshold velocity/speed "axis/spindle stationary", refer to /FBD/, A2	—
36620	SERVO_DISABLE_DELAY_TIME	Shutdown delay, controller enable, refer to /FBD/, A2	—
36901	SAFE_FUNCTION_ENABLE	Enable safety-related functions	●
36902	SAFE_IS_ROT_AX	Rotary axis	●
36905	SAFE_MODULO_RANGE	Modulo value, safe cams	●
36910	SAFE_ENC_SEGMENT_NR	Actual-value assignment: Drive type	●
36911	SAFE_ENC_MODULE_NR	Actual-value assignment: Drive number/measuring circuit number	●
36912	SAFE_ENC_INPUT_NR	Actual-value assignment: Drive encoder number	●
36915	SAFE_ENC_TYPE	Encoder type	●
36916	SAFE_ENC_IS_LINEAR	Linear scale	●
36917	SAFE_ENC_GRID_POINT_DIST	Grid spacing, linear scale	●
36918	SAFE_ENC_RESOL	Encoder pulses per revolution	●
36920	SAFE_ENC_GEAR_PITCH	Leadscrew pitch	●
36921	SAFE_ENC_GEAR_DENOM[n]	Denominator, gearbox ratio encoder/load	●
36922	SAFE_ENC_GEAR_NUMERA[n]	Numerator, gearbox ratio encoder/load	●
36925	SAFE_ENC_POLARITY	Direction of rotation reversal actual value	●
36926	SAFE_ENC_FREQ_LIMIT	Encoder frequency for safe operation	●
36930	SAFE_STANDSTILL_TOL	Standstill tolerance	●
36931	SAFE_VELO_LIMIT[n]	Limit value for safely-reduced speed	●
36932	SAFE_VELO_OVR_FACTOR[n]	SG selection values	●
36933	SAFW_DES_VELO_LIMIT	SG setpoint speed limiting	—
36934	SAFE_POS_LIMIT_PLUS[n]	Upper limit value for safe limit position	●
36935	SAFE_POS_LIMIT_MINUS[n]	Lower limit value for safe limit position	●
36936	SAFE_CAM_POS_PLUS[n]	Plus cams position for safe cams	●
36937	SAFE_CAM_POS_MINUS[n]	Minus cams position for safe cams	●
36940	SAFE_CAM_TOL	Tolerance for safe cams	●
36942	SAFE_POS_TOL	Tolerance, actual value comparison (crosswise)	●
36944	SAFE_REFP_POS_TOL	Tolerance, actual value comparison (referencing)	●
36946	SAFE_VELO_X	Speed limit n_x	●
36948	SAFE_STOP_VELO_TOL	Velocity tolerance for the safe braking ramp	●
36949	SAFE_SLIP_VELO_TOL	Speed tolerance, slip	●
36950	SAFE_MODE_SWITCH_TIME	Tolerance time for SGE changeover	●
36951	SAFE_VELO_SWITCH_DELAY	Delay time, speed changeover	●

6.1 Machine data for SINUMERIK 840D

Table 6-1 Overview of machine data for SINUMERIK 840D

No.	Identifier	Name	Checksum MD
36952	SAFE_STOP_SWITCH_TIME_C	Transition time, STOP C to safe standstill	●
36953	SAFE_STOP_SWITCH_TIME_D	Transition time, STOP D to safe standstill	●
36954	SAFE_STOP_SWITCH_TIME_E	Transition time, STOP E to safe standstill	●
36955	SAFE_STOP_SWITCH_TIME_F	Transition time STOP F to STOP B	●
36956	SAFE_PULSE_DISABLE_DELAY	Delay time, pulse cancellation	●
36957	SAFE_PULSE_DIS_CHECK_TIME	Time to check pulse cancellation	●
36958	SAFE_ACCEPTANCE_TST_TIMEOUT	Time limit for acceptance test	●
36960	SAFE_STANDSTILL_VELO_TOL	Shutdown speed, pulse cancellation	●
36961	SAFE_VELO_STOP_MODE	Stop response, safely-reduced speed	●
36962	SAFE_POS_STOP_MODE	Stop response, safe limit position	●
36963	SAFE_VELO_STOP_REACTION[n]	Stop response, SG-specific	●
36964	SAFE_IPO_STOP_GROUP	Grouping, safety IPO response	—
36965	SAFE_PARK_ALARM_SUPPRESS	Alarm suppression for parking axes	●
36966	SAFE_BRAKETEST_TORQUE	Holding torque, brake test	●
36967	SAFE_BRAKETEST_POS_TOL	Position tolerance, brake test	●
36968	SAFE_BRAKETEST_CONTROL	Sequence check for the brake test	●
36970	SAFE_SVSS_DISABLE_INPUT	Input assignment, SBH/SG de-selection	●
36971	SAFE_SS_DISABLE_INPUT	Input assignment, SBH de-selection	●
36972	SAFE_VELO_SELECT_INPUT[n]	Input assignment, SG selection	●
36973	SAFE_POS_SELECT_INPUT	Input assignment, SE selection	●
36974	SAFE_GEAR_SELECT_INPUT[n]	Input assignment, gearbox ratio selection	●
36975	SAFE_STOP_REQUEST_INPUT	Input assignment, test stop selection	●
36976	SAFE_PULSE_STATUS_INPUT	Input assignment, status pulses cancelled	●
36977	SAFE_EXT_STOP_INPUT[n]	Input assignment, external brake request	●
36978	SAFE_OVR_INPUT[n]	Input assignment, SG override selection	●
36979	SAFE_STOP_REQUEST_EXT_INPUT	Assigning the input terminal to select the test of the external shutdown	●
36980	SAFE_SVSS_STATUS_OUTPUT	Output assignment, SBH/SG active	●
36981	SAFE_SS_STATUS_OUTPUT	Output assignment for SBH active	●
36982	SAFE_VELO_STATUS_OUTPUT[n]	Output assignment, SG active	●
36984	SAFE_EXT_PULSE_ENABLE_OUTPUT	Assignment of the output terminal for the request "externally enable pulses"	●
36985	SAFE_VELO_X_STATUS_OUTPUT	Output assignment for $n < n_x$	●
36986	SAFE_PULSE_ENABLE_OUTPUT	Output assignment, enable pulses	●
36987	SAFE_REFP_STATUS_OUTPUT	Output assignment, axis safely referenced	●
36988	SAFE_CAM_PLUS_OUTPUT[n]	Output assignment, SN1+ to SN4+	●
36989	SAFE_CAM_MINUS_OUTPUT[n]	Output assignment, SN1- to SN4-	●
36990	SAFE_ACT_STOP_OUTPUT[n]	Output assignment, active STOP	●

6.1 Machine data for SINUMERIK 840D

Table 6-1 Overview of machine data for SINUMERIK 840D

No.	Identifier	Name	Checksum MD
36992	SAFE_CROSSCHECK_CYCLE	Displays the axial crosswise comparison clock cycle	—
36993	SAFE_CONFIG_CHANGE_DATE[n]	Date/time of the last change SI–NCK–MD	—
36994	SAFE_PREV_CONFIG[n]	Data, previous safety function	—
36995	SAFE_STANDSTILL_POS	Standstill position	—
36997	SAFE_ACKN	User agreement	—
36998	SAFE_ACT_CHECKSUM	Actual checksum	—
36999	SAFE_DES_CHECKSUM	Reference checksum	—
37000	FIXED_STOP_MODE	Mode, traverse to fixed endstop	—

6.1.2 Description of machine data

General information

General information about machine data and an explanation of their contents such as units, data type, protective stage, effectiveness, etc. can be found in the following references:

References: /LIS/, Lists, SINUMERIK 840D

10050	\$MN_SYSLOCK_CYCLE_TIME		
MD number	Basic system clock cycle		
Standard value: 0.004	Min. input limit: 0.000125	Max. input limit: 0.031	
Change becomes effective after: Power on	Protective stage: 7/2	Units: s	
Data type: DOUBLE	applies from SW release: 6.4.09		
Meaning:	<p>The clock cycle times of cyclic tasks (position controller/IPO) are set in a multiple of this basic clock cycle. Apart from special applications in which POSCTRL_SYSCLOCK_TIME_RATIO is set to a value greater than 1, the basic clock cycle corresponds to the position controller clock cycle.</p> <p>When using a digital drive, the basic clock cycle time and POSCTRL_SYSCLOCK_TIME_RATIO must be set so that the position controller clock cycle is not longer than 16 ms (otherwise a drive alarm is output). The set value is offset (alarm) as a result of automatic corrections when booting</p> <p>For systems with Profibus–DP connection, this MD corresponds to the Profibus DP cycle time. When booting, this time is read out of the configuring file SDB1000 and written into the MD. This MD can only be changed using the configuring file.</p> <p>Note:</p> <p>If this MD is reduced, then this can result in an automatic correction of POSCTRL_CYCLE_DELAY, that cannot be undone at the next increase!</p> <p>Details:</p> <p>The basic clock cycle is an integer multiple (SYSCLOCK_SAMPL_TIME_RATIO) of units of the clock cycle of the measured value sampling. When the system boots, the entered value is automatically rounded to a multiple of this incrementing.</p>		

6.1 Machine data for SINUMERIK 840D

10089	\$MN_SAFE_PULSE_DIS_TIME_BUSFAIL		
MD number	Delay time until the pulses are cancelled when the drive bus fails		
Standard value: 0	Min. input limit: 0	Max. input limit: 0.8	
Change becomes effective after: Power on	Protective stage: 7/2	Units: s	
Data type: DOUBLE	applies from SW release: 6.4.09		
Meaning:	<p>After the drive bus fails, the pulses must have been safely cancelled after this time has expired. During this time it is still possible to implement a response to the bus failure that is executed autonomously in the drive (refer to extended stopping and retraction). In the following cases, the pulses are immediately cancelled (the system does not wait for this delay time to expire):</p> <ul style="list-style-type: none"> • When selecting an external Stop A, a test stop or a test stop – external shutdown • For active SBH or when selecting SBH • For an active SG stage or when selecting an SG stage for which an immediate pulse cancellation is parameterized in \$MA_SAFE_VELO_STOP_MODE or \$MA_SAFE_VELO_STOP_REACTION 		
Special cases, errors,...	<p>\$MN_SAFE_PULSE_DIS_TIME_BUSFAIL is transferred using the copy function of the SI-MD into drive MD 1380 and then subject to a crosswise data comparison. These general machine data are included in the axial checksum calculation of the safety-related machine data (\$MA_SAFE_ACT_CHECKSUM, \$MA_SAFE_DES_CHECKSUM).</p>		
corresponds with..			

10090	\$MN_SAFETY_SYSCLOCK_TIME_RATIO		
MD number	Factor for the monitoring clock cycle		
Standard value: 3	Min. input limit: 1	Max. input limit: 50	
Change becomes effective after: Power on	Protective stage: 7/2	Units: –	
Data type: DWORD	applies from SW release: 3.4		
Meaning:	<p>Ratio between the monitoring and basic system clock cycle. The monitoring clock cycle is the product of this data and \$MN_SYSCLOCK_CYCLE_TIME.</p>		
Special cases, errors,...	<p>The monitoring clock cycle is checked when the system runs-up:</p> <ul style="list-style-type: none"> • It must be an integral multiple of the position control clock cycle • it must be ≤ 25 ms <p>If these conditions are not fulfilled, the factor is rounded-off to the next possible value. The monitoring cycle that is actually set is displayed using \$MN_INFO_SAFETY_CYCLE_TIME.</p> <p>Further, the value for the crosswise data comparison clock cycle that is displayed using \$MN_INFO_CROSSCHECK_CYCLE_TIME also changes.</p> <p>Note: The monitoring clock cycle defines the response time of the monitoring functions. It should be noted that a short monitoring clock cycle time increases the load on the CPU.</p>		
corresponds with..	<p>MD 10050: \$MN_SYSCLOCK_CYCLE_TIME MD 10091: \$MN_INFO_SAFETY_CYCLE_TIME MD 10092: \$MN_INFO_CROSSCHECK_CYCLE_TIME</p>		

6.1 Machine data for SINUMERIK 840D

10091	\$MN_INFO_SAFETY_CYCLE_TIME		
MD number	Displays the monitoring clock cycle		
Standard value: 0	Min. input limit: –	Max. input limit:	
Change becomes effective after: Power on	Protective stage: 7/–	Units: s	
Data type: DOUBLE	applies from SW release: 3.4		
Meaning:	Display data: Displays the actually effective monitoring clock cycle. This data cannot be written to.		
corresponds with..	MD 10090: \$MN_SAFETY_SYSCLOCK_TIME_RATIO		
Additional references	Refer to Chapter 4.1 "Monitoring clock cycle" and Chapter 4.2 "Crosswise data comparison"		

10092	\$MN_INFO_CROSSCHECK_CYCLE_TIME		
MD number	Displays the crosswise data comparison clock cycle		
Standard value: 0	Min. input limit: –	Max. input limit:	
Change becomes effective after: Power on	Protective stage: (L/S): 7/–	Units: s	
Data type: DOUBLE	applies from SW release:		
Meaning:	This data displays the effective time for one full execution of the crosswise data comparison clock cycle. For display purposes only – it cannot be written into. From SW 6.3.21 onwards: Maximum crosswise data comparison clock cycle in seconds.		
corresponds with...	MD 10090: \$MN_SAFETY_SYSCLOCK_TIME_RATIO		
Additional references	Refer to Chapter 4.1: "Monitoring clock cycle" and Chapter 4.2 "Crosswise data comparison"		

10093	\$MN_INFO_NUM_SAFE_FILE_ACCESS		
MD number	Number of SPL file access operations		
Standard value: 0	Min. input limit: –	Max. input limit: –	
Change becomes effective after: Power on	Protective stage: –/–	Units:	
Data type: DWORD	applies from SW release: 4.4.18		
Meaning:	Display data: SPL file /_N_CST_DIR/_N_SAFE_SPF has been accessed n–times in the protected state. This MD is only used for service purposes. The value of the MD can only be 0 or 1. The value cannot be changed.		
Special cases, errors,...			

6.1 Machine data for SINUMERIK 840D

10094	\$MN_SAFE_ALARM_SUPPRESS_LEVEL		
MD number	"Safety Integrated" alarm suppression		
Standard value: 2	Min. input limit: 0	Max. input limit: 13	
Change becomes effective after: Power on	Protective stage: 7/2	Units: –	
Data type: BYTE	applies from SW release: 6		
Meaning:	<p>The monitoring channels NCK and 611 digital display alarms with the same significance in several situations.</p> <p>In order to reduce the size of the alarm screen, this MD is used to specify whether safety alarms with the same significance are to be suppressed. The two-channel stop response is not influenced by the setting.</p> <p>0 = alarms triggered in two channels are displayed to the full extent</p> <ul style="list-style-type: none"> – Two-channel display of all axial safety alarms – Alarm 27001, fault code 0 is displayed – Alarms 27090, 27091, 27092, 27093 and 27095 are displayed through two channels and a multiple number of times. <p>1 = alarms with the same meaning are only displayed once.</p> <p style="padding-left: 20px;">This involves the following alarms:</p> <p style="padding-left: 20px;">27010 = 300907 27011 = 300914 27012 = 300915 27013 = 300906 27020 = 300910 27021 = 300909 27022 = 300908 27023 = 300901 27024 = 300900</p> <p>For these alarms, only one of the specified alarms (270xx or 300xxx) is initiated. The alarm of the monitoring channel that then subsequently initiates the alarm with the same significance, is no longer displayed.</p> <p>Furthermore, Alarm 27001 with fault code 0 is suppressed. This alarm occurs as a result of drive Alarm 300911. In this particular case, drive machine data 1391, 1392, 1393, 1394 provide information regarding the cause of the error.</p> <p>2 = default setting</p> <p>Going beyond the functionality with MD value=1, the alarms from the SPL processing (27090, 27091, 27092, 27093 and 27095) are only displayed through one channel and only once.</p> <p>This machine data must be set to 0 to generate an acceptance report. This allows the system to document all of the alarms that have been initiated.</p> <p>3 = axial Alarms 27000 and 300950 are replaced by Alarm message 27100 for all axes/drives.</p> <p>12 = going beyond the functionality with MD value = 2, the alarms are assigned priorities. What appears to be apparent follow-on alarms are no longer displayed or are automatically cleared from the display.</p> <p>The following alarms may be involved: 27001, 27004, 27020, 27021, 27022, 27023, 27024, 27091, 27101, 27102, 27103, 27104, 27105, 27106, 27107</p> <p>13 = going beyond the functionality with MD value = 3, the alarms are assigned priorities as for MD value 12.</p> <p>This machine data must be set to 0 to generate an acceptance report. This allows the system to document all of the alarms that have been initiated.</p>		
Special cases, errors,...			

6.1 Machine data for SINUMERIK 840D

10095	\$MN_SAFE_MODE_MASK		
MD number	Safety Integrated modes		
Standard value: 0	Min. input limit: 0	Max. input limit: 0x0001	
Change becomes effective after: Power on	Protective stage: 7/2	Units: –	
Data type: DWORD	applies from SW release: 5.3		
Meaning:	Bit 0=0 \$A_INSI[1...64] default setting "0" Bit 0=1 \$A_INSI[1...64] default setting "1" The default setting is made in 32-bit groups and only if at least one of the system variables in this groups was parameterized as axial SGA. (compatibility mode for older PLC software releases) These functions are only supported by the NCK in one channel. This data is not included in the axial MD checksum SAFE_ACT_CHECKSUM.		
Special cases, errors,...			

10096	\$MN_SAFE_DIAGNOSIS_MASK		
MD number	Safety Integrated diagnostic functions		
Standard value: 1	Min. input limit: 0	Max. input limit: 0x0001	
Change becomes effective after: Power on	Protective stage: 7/2	Units: –	
Data type: DWORD	applies from SW release: 5.3		
Meaning:	Bit 0=0 SGE differences between NCK and 611digital monitoring channels are not displayed Bit 0=1 SGE differences between NCK and 611digital monitoring channels are displayed Differences between the following SGEs are detected (the listed bit numbers refer to the axial mapping of the SGEs – these correspond to the following VDI interface assignment): Bit 0: SBH/SG de-selection = DB3<x>.DBX22.0 Bit 1: SBH de-selection = DB3<x>.DBX22.1 Bit 3: SG selection, bit 0 = DB3<x>.DBX22.3 Bit 4: SG selection, bit 1 = DB3<x>.DBX22.4 (from SW 6) Bit 12: SE selection = DB3<x>.DBX23.4 Bit 28: SG correction, bit 0 = DB3<x>.DBX33.4 Bit 29: SG correction, bit 1 = DB3<x>.DBX33.5 Bit 30: SG correction, bit 2 = DB3<x>.DBX33.6 Bit 31: SG correction, bit 3 = DB3<x>.DBX33.7 <x> is the axis number The differences are indicated using Alarm 27004.		
Special cases, errors,...			

6.1 Machine data for SINUMERIK 840D

10097	\$MN_SAFE_SPL_STOP_MODE		
MD number	Stop response for SPL errors		
Standard value: 3	Min. input limit: 3	Max. input limit: 4	
Change becomes effective after: Power on		Protective stage: 2/7	Units: –
Data type: BYTE		applies from SW release: 6.3	
Meaning:	<p>Selects the stop response when errors are detected in the crosswise data comparison of NCK and PLC–SPL</p> <p>3: Stop D 4: Stop E</p> <p>When the value 4 is entered in this MD (Stop E) without enabling the external Stop E in all axes with SI function enable signals (\$MA_SAFE_FUNCTION_ENABLE not equal to 0) results in Alarm 27033, "Axis %1 Invalid parameterization of MD \$MN_SAFE_SPL_STOP_MODE".</p> <p>To remedy this, either parameterize Stop D or set bit 4 and bit 6 in \$MA_SAFE_FUNCTION_ENABLE for all of the axes involved. This machine data is incorporated in the checksum for safety–related machine data (\$MA_SAFE_ACT_CHECKSUM, \$MA_SAFE_DES_CHECKSUM)</p>		
Special cases, errors,...			

10098	\$MN_PROFISAFE_IPO_TIME_RATIO		
MD number	Factor PROFIsafe communications clock cycle time		
Standard value: 1	Min. input limit: 1	Max. input limit: 25	
Change becomes effective after: Power on		Protective stage: 7/2	Units: –
Data type: DWORD		applies from SW release: 6.3	
Meaning:	<p>Relationship between the interpolator clock cycle and the clock cycle in the communications with PROFIsafe I/O modules. In the resulting time grid, OB40 on the PLC side is initiated from the NCK to enable communication between the F master and F slaves. The value obtained for the communication clock cycle from this MD and the set IPO clock cycle may not be greater than 25 ms.</p>		
Special cases, errors,...			

10099	\$MN_INFO_PROFISAFE_CYCLE_TIME		
MD number	PROFIsafe communications clock cycle time		
Standard value: 0.000	Min. input limit: –	Max. input limit: –	
Change becomes effective after: Power on		Protective stage: 7/–	Units: s
Data type: DOUBLE		applies from SW release: 6.3	
Meaning:	<p>Display data: Time grid for communications between an F master and F slaves. The value is obtained from the interpolator clock cycle and MD \$MN_PROFISAFE_IPO_TIME_RATIO.</p> <p>The value cannot be changed. PROFIsafe communications via the OB40 in the PLC use this time grid.</p>		
Special cases, errors,...			

6.1 Machine data for SINUMERIK 840D

10385	\$MN_PROFISAFE_MASTER_ADDRESS		
MD number	PROFIsafe address of the PROFIsafe module		
Standard value: 0	Min. input limit: 0	Max. input limit: 0x0500FA7D	
Change becomes effective after: Power on	Protective stage: 7/2	Units: –	
Data type: DWORD	applies from SW release: 6.3		
Meaning:	Defines the PROFIsafe address for the F master NCK/PLC. This is used to uniquely assign an F master to an F slave. This parameter must be entered in accordance with the "F_source_address" parameter set in S7-ES for the F slaves. An attempt to establish communications is only made for F slaves that have entered this address.		
Special cases, errors,...			

10386	\$MN_PROFISAFE_IN_ADDRESS[n]: 0 ... 15		
MD number	PROFIsafe address of an input module		
Standard value: 0	Min. input limit: 0	Max. input limit: 0x0501FFFF	
Change becomes effective after: Power on	Protective stage: 7/2	Units: –	
Data type: DWORD	applies from SW release: 6.3		
Meaning:	PROFIsafe target address of an input module Format: 0s 0x aaaa s: Bus segment (5 = DP connection on the PLC side) x: Sub-slot address Value range: 0...1 x = 0 addresses the F net data signals 1...32 x = 1 addresses the F net data signals 33...64 aaaa: Hexadecimal PROFIsafe address of the F module		
Special cases, errors,...			

10387	\$MN_PROFISAFE_OUT_ADDRESS[n]: 0 ... 15		
MD number	PROFIsafe address of an output module		
Standard value: 0	Min. input limit: 0	Max. input limit: 0x0501FFFF	
Change becomes effective after: Power on	Protective stage: 7/2	Units: –	
Data type: DWORD	applies from SW release: 6.3		
Meaning:	Defines the PROFIsafe address of a PROFIsafe output module Format: 0s 0x aaaa s: Bus segment (5 = DP connection on the PLC side) x: Sub-slot address Value range: 0...1 x = 0 addresses the F net data signals 1...32 x = 1 addresses the F net data signals 33...64 aaaa: Hexadecimal PROFIsafe address of the F module		
Special cases, errors,...			

6.1 Machine data for SINUMERIK 840D

10388	\$MN_PROFISAFE_IN_ASSIGN[n]: 0 ... 15		
MD number	Input assignment \$A_INSE and PROFIsafe module		
Standard value: 0	Min. input limit: 0	Max. input limit: 64064	
Change becomes effective after: PowerOn	Protective stage: 7/2	Units: –	
Data type: DWORD	applies from SW release: 6.3		
Meaning:	Assignment between an ext. SPL interface \$A_INSE and a PROFIsafe input module. The three lower positions indicate the least significant \$A_INSE variable to be supplied. The three upper positions indicate the most significant \$A_INSE variable to be supplied. Example: PROFISAFE_IN_ASSIGN[0] = 4001: The system variables \$A_INSE[1...4] are supplied with the state of the input terminals of the PROFIsafe module that was defined in MD PROFISAFE_IN_ADDRESS[0].		
Special cases, errors,...			

10389	\$MN_PROFISAFE_OUT_ASSIGN[n]: 0 ... 15		
MD number	Output assignment \$A_OUTSE to PROFIsafe module		
Standard value: 0	Min. input limit: 0	Max. input limit: 64064	
Change becomes effective after: RESTART	Protective stage: 7/2	Units: –	
Data type: DWORD	applies from SW release: 6.3		
Meaning:	Assignment between an ext. SPL interface \$A_OUTSE and a PROFIsafe output module. The three lower positions indicate the least significant \$A_OUTSE variable to be connected. The three upper positions indicate the most significant \$A_OUTSE variable to be connected. Example: PROFISAFE_IN_ASSIGN[0] = 64061: The system variables \$A_OUTSE[1...64] are supplied at the output terminals of the PROFIsafe module defined in MD PROFISAFE_OUT_ADDRESS[0].		
Special cases, errors,...			

The following machine data

\$MN_INFO_PROFISAFE_CYCLE_TIME
\$MN_PROFISAFE_MASTER_ADDRESS
\$MN_PROFISAFE_IN_ADDRESS
\$MN_PROFISAFE_OUT_ADDRESS
\$MN_PROFISAFE_IN_ASSIGN
\$MN_PROFISAFE_OUT_ASSIGN

are included in the axial checksum machine data \$MA_SAFE_ACT_CHECKSUM. This means that they are protected against changes. Changes can only be confirmed and activated by pressing "Confirm SI data" softkey.

Changes to the machine data and resulting axial checksums are displayed using Alarm 27032, "Axis %1 checksum error for safe monitoring. Acknowledgment and acceptance test necessary!".

6.1 Machine data for SINUMERIK 840D

10390	\$MN_SAFE_IN_HW_ASSIGN[n]: 0...7																													
MD number	Input assignment, ext. interface SPL																													
Standard value: 0	Min. input limit: 0	Max. input limit: 01 1E 08 02																												
Change becomes effective after: Power on	Protective stage: 7/2	Units: –																												
Data type: DWORD	applies from SW release: 4.4.18																													
Meaning:	<p>One input byte of the NCK I/Os can be assigned bitwise (byte–serially) to the system variables \$A_INSE[x] using this machine data.</p> <table> <thead> <tr> <th>n</th> <th>System variables</th> <th>Comment</th> </tr> </thead> <tbody> <tr> <td>= 0</td> <td>\$A_INSE[1..8]</td> <td>Assignment for the 1st byte</td> </tr> <tr> <td>= 1</td> <td>\$A_INSE[9..16]</td> <td>Assignment for the 2nd byte</td> </tr> <tr> <td>= 2</td> <td>\$A_INSE[17..24]</td> <td>Assignment for the 3rd byte</td> </tr> <tr> <td>= 3</td> <td>\$A_INSE[25..32]</td> <td>Assignment for the 4th byte</td> </tr> <tr> <td>= 4</td> <td>\$A_INSE[33..40]</td> <td>Assignment for the 5th byte</td> </tr> <tr> <td>= 5</td> <td>\$A_INSE[41..48]</td> <td>Assignment for the 6th byte</td> </tr> <tr> <td>= 6</td> <td>\$A_INSE[49..56]</td> <td>Assignment for the 7th byte</td> </tr> <tr> <td>= 7</td> <td>\$A_INSE[57..64]</td> <td>Assignment for the 8th byte</td> </tr> </tbody> </table> <p>Structure: Refer to MD 10366: \$MN_HW_ASSIGN_DIG_FASTIN. In this case the restriction applies that an I/O module must be addressed via this MD. It is not possible to assign to another system variable.</p>			n	System variables	Comment	= 0	\$A_INSE[1..8]	Assignment for the 1st byte	= 1	\$A_INSE[9..16]	Assignment for the 2nd byte	= 2	\$A_INSE[17..24]	Assignment for the 3rd byte	= 3	\$A_INSE[25..32]	Assignment for the 4th byte	= 4	\$A_INSE[33..40]	Assignment for the 5th byte	= 5	\$A_INSE[41..48]	Assignment for the 6th byte	= 6	\$A_INSE[49..56]	Assignment for the 7th byte	= 7	\$A_INSE[57..64]	Assignment for the 8th byte
n	System variables	Comment																												
= 0	\$A_INSE[1..8]	Assignment for the 1st byte																												
= 1	\$A_INSE[9..16]	Assignment for the 2nd byte																												
= 2	\$A_INSE[17..24]	Assignment for the 3rd byte																												
= 3	\$A_INSE[25..32]	Assignment for the 4th byte																												
= 4	\$A_INSE[33..40]	Assignment for the 5th byte																												
= 5	\$A_INSE[41..48]	Assignment for the 6th byte																												
= 6	\$A_INSE[49..56]	Assignment for the 7th byte																												
= 7	\$A_INSE[57..64]	Assignment for the 8th byte																												
corresponds with...	MD 10392: \$MN_SAFE_OUT_HW_ASSIGN																													
Additional references	Refer to Chapter 5.10, "Safe programmable logic (SPL)"																													

10392	\$MN_SAFE_OUT_HW_ASSIGN[n]: 0...7																													
MD number	Output assignment, ext. interface SPL																													
Standard value: 0	Min. input limit: 0	Max. input limit: 01 1E 08 02																												
Change becomes effective after: Power on	Protective stage: 7/2	Units: –																												
Data type: DWORD	applies from SW release: 4.4.18																													
Meaning:	<p>One output byte of the NCK I/Os can be assigned bitwise (byte–serially) to the system variables \$A_OUTSE[x] using this machine data.</p> <table> <thead> <tr> <th>n</th> <th>System variables</th> <th>Comment</th> </tr> </thead> <tbody> <tr> <td>= 0</td> <td>\$A_OUTSE[1..8]</td> <td>Assignment for the 1st byte</td> </tr> <tr> <td>= 1</td> <td>\$A_OUTSE[9..16]</td> <td>Assignment for the 2nd byte</td> </tr> <tr> <td>= 2</td> <td>\$A_OUTSE[17..24]</td> <td>Assignment for the 3rd byte</td> </tr> <tr> <td>= 3</td> <td>\$A_OUTSE[25..32]</td> <td>Assignment for the 4th byte</td> </tr> <tr> <td>= 4</td> <td>\$A_OUTSE[33..40]</td> <td>Assignment for the 5th byte</td> </tr> <tr> <td>= 5</td> <td>\$A_OUTSE[41..48]</td> <td>Assignment for the 6th byte</td> </tr> <tr> <td>= 6</td> <td>\$A_OUTSE[49..56]</td> <td>Assignment for the 7th byte</td> </tr> <tr> <td>= 7</td> <td>\$A_OUTSE[57..64]</td> <td>Assignment for the 8th byte</td> </tr> </tbody> </table> <p>Structure: Refer to MD 10364: \$MN_HW_ASSIGN_DIG_FASTOUT. In this case the restriction applies that an I/O module must be addressed via this MD. It is not possible to assign to another system variable.</p>			n	System variables	Comment	= 0	\$A_OUTSE[1..8]	Assignment for the 1st byte	= 1	\$A_OUTSE[9..16]	Assignment for the 2nd byte	= 2	\$A_OUTSE[17..24]	Assignment for the 3rd byte	= 3	\$A_OUTSE[25..32]	Assignment for the 4th byte	= 4	\$A_OUTSE[33..40]	Assignment for the 5th byte	= 5	\$A_OUTSE[41..48]	Assignment for the 6th byte	= 6	\$A_OUTSE[49..56]	Assignment for the 7th byte	= 7	\$A_OUTSE[57..64]	Assignment for the 8th byte
n	System variables	Comment																												
= 0	\$A_OUTSE[1..8]	Assignment for the 1st byte																												
= 1	\$A_OUTSE[9..16]	Assignment for the 2nd byte																												
= 2	\$A_OUTSE[17..24]	Assignment for the 3rd byte																												
= 3	\$A_OUTSE[25..32]	Assignment for the 4th byte																												
= 4	\$A_OUTSE[33..40]	Assignment for the 5th byte																												
= 5	\$A_OUTSE[41..48]	Assignment for the 6th byte																												
= 6	\$A_OUTSE[49..56]	Assignment for the 7th byte																												
= 7	\$A_OUTSE[57..64]	Assignment for the 8th byte																												
corresponds with...	MD 10390: \$MN_SAFE_IN_HW_ASSIGN																													
Additional references	Refer to Chapter 3, "Safe programmable logic (SPL)"																													

Assigning local inputs on the NCU to the external SPL interface (from SW 6.3.21):

- Parameterization for s = 0 for SPL SGEs/SGAs:
 - i = 0H fixed
 - mm = 00H fixed
 - xx = 00H fixed
 - nn = 01H – 0FH screen for the digital I/O used for safety inputs/outputs

Setting the value "nn" can be used to define which of the available four digital I/Os is/are to be used for the SPL SGEs/SGAs:

Examples

nn = 01H: only map input/output 1 in \$A_INSE/\$A_OUTSE

nn = 05H: only map inputs/outputs 1 and 3 in \$A_INSE/\$A_OUTSE

nn = 0FH: map all inputs/outputs in \$A_INSE/\$A_OUTSE

This parameterization allows individual I/Os to be reserved for SI and, at the same time, the other I/Os to be used for other functions.

A single output bit is connected to a terminal with each entry. The structure is the same as \$MN_HW_ASSIGN_ANA_FASTOUT[n].

13300	\$MN_PROFISAFE_IN_FILTER		
MD number	F useful (net) data filter IN		
Standard value 0xFFFFFFFF	Min. input limit: 0	Max. input limit: –	
Change becomes effective after: Power on	Protective stage: 7/2	Units: –	
Data type: DWORD	applies from SW release: 7.1		
Meaning:	<p>Filter between F net (useful) data and \$A_INSE variables MD PROFISAFE_IN_FILTER is used to define which F net data bits of the PROFIsafe module are accepted for further processing from the F net data interface of the PROFIsafe module in the NCK. The filtered F net data bits are pushed together inside the NCK to form a bit array without any gaps (consecutive bit array). MD PROFISAFE_IN_ASSIGN is then used to define in which \$A_INSE variables, the filtered F net data bits are transferred.</p> <p><u>Example:</u> Note: For reasons of simplicity, only 16 bits are taken into consideration. Parameterization: PROFISAFE_IN_FILTER=A944H PROFISAFE_IN_ASSIGN=011006 n=16 11 6 1 x x x x x x 1 1 1 0 0 1 x x x x x \$INSE[n], x=not relevant 0 0 0 0 0 0 0 0 0 1 1 1 0 0 1 NCK–internal F net data image 1 0 1 0 1 0 0 1 0 1 0 0 0 1 0 0 \$MN_PROFISAFE_IN_FILTER 1 0 1 0 1 0 0 0 0 0 0 0 0 1 0 0 as an example, value at the F net data interface of the PROFIsafe module</p>		
corresponds with...			
Additional references			

6.1 Machine data for SINUMERIK 840D

13301	\$MN_PROFISAFE_OUT_FILTER		
MD number	F net (useful) data filter OUT		
Standard value 0xFFFFFFFF	Min. input limit: –	Max. input limit: –	
Change becomes effective after: Power on	Protective stage: 7/2	Units: –	
Data type: DWORD	applies from SW release: 7.1		
Meaning:	<p>Filter between F net (useful) data and \$A_OUTSE variables MD PROFISAFE_OUT_ASSIGN is used to define which OUTSE[n] variables are transferred in the F net data bits of the PROFIsafe module. MD PROFISAFE_OUT_FILTER is used to define which F net data bit is transferred to the particular \$OUTSE[n] variable. Example: Note: For reasons of simplicity, only 16 bits are taken into consideration. Parameterization: \$MN_PROFISAFE_OUT_FILTER=1010100101000100 \$MN_PROFISAFE_OUT_ASSIGN=011006 n=16 11 6 1 x x x x x 1 1 1 1 1 x x x x x as an example, a value available in the \$OUTSE variables, x=not relevant 0 0 0 0 0 0 0 0 0 1 1 1 1 1 1 F net data image in the NCK 1 0 1 0 1 0 0 1 0 1 0 0 0 1 0 0 \$MN_PROFISAFE_IN_FILTER 1 0 1 0 1 0 0 1 0 1 0 0 0 1 0 0 F net data of the PROFIsafe module</p>		
corresponds with...			
Additional references			

20108	\$MC_PROG_EVENT_MASK		
MD number	Event-controlled program call		
Standard value (0x0, 0x0,...)	Min. input limit: 0	Max. input limit: 0xF	
Change becomes effective after: Power on	Protective stage: 7/2	Units: –	
Data type: DWORD	applies from SW release: 6.1		
Meaning:	<p>Parameterizes the event where the user program, set with \$MN_PROG_EVENT_NAME (default: _N_PROG_EVENT_SPF) is implicitly called: Bit 0 = 1: Part program start Bit 1 = 1: Part program end Bit 2 = 1: Operator panel reset Bit 3 = 1: Run-up The user program is called using the following search path: 1. /_N_CUS_DIR/_NPROG_EVENT_SPF 2. /_N_CMA_DIR/_NPROG_EVENT_SPF 3. /_N_CST_DIR/_NPROG_EVENT_SPF</p>		
corresponds with...			
Additional references			

6.1 Machine data for SINUMERIK 840D

36901	\$MA_SAFE_FUNCTION_ENABLE		
MD number	Enable safety-relevant functions		
Standard value: 0	Min. input limit: 0	Max. input limit: 0xFFFFB	
Change becomes effective after: Power on	Protective stage: 7/2	Units: Hexadecimal	
Data type: DWORD	applies from SW release: 3.4		
Meaning:	<p>The functions for safe operation can be enabled for one axis/spindle using this machine data.</p> <p>It is only possible to enable – on an axis-specific basis – as many axes/spindles for safe operation as have been enabled by the global option.</p> <p>The more partial functions that are set then the more computing time the safe functions require.</p> <p>Bit 0: Enable safely-reduced speed, safe operating stop Bit 1: Enable safe limit switch Bit 2: Reserved Bit 3: Enable actual value synchron. 2-encoder system Bit 4: Enable external ESR activation (STOP E) Bit 5: Enable SG/correction/override Bit 6: Enable the external stop requests/external stops Bit 7: Enable cam synchronization Bit 8: Enable safe cam, pair 1, cam+ Bit 9: Enable safe cam, pair 1, cam- Bit 10: Enable safe cam, pair 2, cam+ Bit 11: Enable safe cam, pair 2, cam- Bit 12: Enable safe cam, pair 3, cam+ Bit 13: Enable safe cam, pair 3, cam- Bit 14: Enable safe cam, pair 4, cam+ Bit 15: Enable safe cam, pair 4, cam-</p>		
Special cases, errors,...	<p>If bit 1 or a higher bit is set, then bit 0 must also be set since the control system switches to a safe operational stop in response to STOP C, D or E (a configuration alarm is output if an error is detected).</p> <p>If an insufficient number of axes/spindles have been enabled for safe operation using the global option, then this data may be overwritten with the value 0000 during run-up</p>		
corresponds with...	Global option		
Additional references	Refer to Chapter: 4.5, "Enabling safety-related functions"		

36902	\$MA_SAFE_IS_ROT_AX		
MD number	Rotary axis		
Standard value: FALSE	Min. input limit: –	Max. input limit: –	
Change becomes effective after: Power on	Protective stage: 7/2	Units: –	
Data type: BOOLEAN	applies from SW release: 3.4		
Meaning:	<p>This data specifies whether the axis for safe operation is a rotary axis/spindle or linear axis.</p> <p>= 0: Linear axis = 1: Rotary axis/spindle</p> <p>The value set in this MD must be the same as the value set in MD: \$MA_IS_ROT_AX. If they are not identical a parameterizing error is displayed.</p>		
corresponds with...	MD 30300: \$MA_IS_ROT_AX		

6.1 Machine data for SINUMERIK 840D

36905	\$MA_SAFE_MODULO_RANGE		
MD number	Modulo value, safe cams		
Standard value: 0.0	Min. input limit: 0.0	Max. input limit: 737280.0	
Change becomes effective after: Power on	Protective stage: 7/2	Units: degrees	
Data type: DOUBLE	applies from SW release: 4.2		
Meaning:	Actual value range within which safe cams for rotary axes are calculated. The axis must be a rotary axis (\$MA_/\$MD_SAFE_IS_ROT_AX = 1). Value = 0: Modulo correction after +/- 2048 revolutions (i.e. after 737 280 degrees) Value > 0 and a multiple of 360 degrees: Modulo correction after this value (e.g. value = 360 degrees – the actual value range lies between 0 and 359.999 degrees; this means that a modulo override is carried-out after every revolution.		
Special cases, errors,...	<ul style="list-style-type: none"> If the value set in this data is not 0 or a multiple of 360 degrees, then an appropriate alarm is output when the system runs-up. The cam positions are also checked with respect to the parameterized actual value when the system runs-up. An appropriate alarm is output if parameterization errors are detected. The actual value ranges set using \$MA_SAFE_MODULO_RANGE and \$MA_MODULO_RANGE must be multiple integers (must be able to be divided without any remainder). 		
corresponds with...	MD 1305: \$MD_SAFE_MODULO_RANGE MD 30330: \$MA_MODULO_RANGE MD 36935/1336: \$MA_/\$MD_SAFE_CAM_POS_PLUS[n] MD 36937/1337: \$MA_/\$MD_SAFE_CAM_POS_MINUS[n]		

36910	\$MA_SAFE_ENC_SEGMENT_NR		
MD number	Actual-value assignment: Drive type		
Standard value: 1	Min. input limit: 0	Max. input limit:	
Change becomes effective after: Power on	Protective stage: 0/0	Units: –	
Data type: BYTE	applies from SW release: 3.4		
Meaning:	Number of the bus segment via which the SI encoder is addressed. =1: Drive bus of the SIMODRIVE 611 digital (this is always used)		
Special cases, errors,...			
corresponds with...			

6.1 Machine data for SINUMERIK 840D

36911	\$MA_SAFE_ENC_MODULE_NR		
MD number	Actual-value assignment: Drive number/measuring circuit number		
Standard value: 1	Min. input limit: 1	Max. input limit: NCU 572: 31	
Change becomes effective after: Power on		Protective stage: 7/2	Units: –
Data type: BYTE		applies from SW release: 3.4	
Meaning:	Module No. within a segment via which the SI encoder is addressed. The logical drive number of the drive assigned to the axis via \$MN_DRIVE_LOGIC_NR must be entered here. For standard applications with a 2–encoder system, the encoder for Safety Integrated is connected to the second encoder connection (lower input) of the same drive module.		
Special cases, errors,...	For the second encoder, any actual value input in the 611digital group can be used as the measuring system on the NC side.		
corresponds with...	MD 36910: \$MA_SAFE_ENC_SEGMENT_NR MD 36912: \$MA_SAFE_ENC_INPUT_NR MD 36010: \$MN_DRIVE_LOGIC_NR MD 30220: \$MA_ENC_MODULE_NR		

36912	\$MA_SAFE_ENC_INPUT_NR		
MD number	Actual-value assignment: Drive encoder number		
Standard value: 1	Min. input limit: 1	Max. input limit: 3	
Change becomes effective after: Power on		Protective stage: 7/2	Units: –
Data type: BYTE		applies from SW release: 3.4	
Meaning:	Number of the actual value input of a module via which the SI encoder is addressed. = 1: SI encoder is connected to the upper input (motor encoder) = 2: SI encoder is connected to the lower input (2nd encoder) For standard applications with a 2–encoder system, the encoder for Safety Integrated is connected to the second encoder connection (lower input) of the same drive module.		
Special cases, errors,...	For the second encoder, any actual value input in the 611digital group can be used as the measuring system on the NC side.		
corresponds with...	MD 36911: \$MA_SAFE_ENC_MODULE_NR MD 30230: \$MA_ENC_INPUT_NR		

36915	\$MA_SAFE_ENC_TYPE		
MD number	Encoder type		
Standard value: 0	Min. input limit: 0	Max. input limit:	
Change becomes effective after: Power on		Protective stage: 7/2	Units: –
Data type: BYTE		applies from SW release: 3.4	
Meaning:	This MD specifies the type of SI encoder connected here. = 0: Reserved = 1: Raw signal encoder (1 V peak-to-peak) = 4: Absolute encoder with EnDat interface		
Special cases, errors,...	<ul style="list-style-type: none"> The value is coded in the same way as in data \$MA_ENC_TYPE. However, only a value of 1 or 4 is permissible. An incorrect configuration (e.g. when a value of 0, 2, 3 or 5 is entered) is flagged using Alarm 27033. 		
corresponds with...	MD 30240: \$MA_ENC_TYPE		

6.1 Machine data for SINUMERIK 840D

36916	\$MA_SAFE_ENC_IS_LINEAR		
MD number	Linear scale		
Standard value: FALSE	Min. input limit: –	Max. input limit: –	
Change becomes effective after: Power on	Protective stage: 7/2	Units: –	
Data type: BOOLEAN	applies from SW release: 3.4		
Meaning:	<p>This MD specifies whether a linear or a rotary encoder is connected.</p> <p>= 0: A rotary encoder is connected \$MA_SAFE_ENC_RESOL is used to specify its resolution and \$MA_SAFE_ENC_GEAR_PITCH, \$MA_SAFE_ENC_GEAR_DENOM[n] and \$MA_SAFE_ENC_GEAR_NUMERA[n] are used to convert it to the load side. The MD: \$MA_SAFE_ENC_GRID_POINT_DIST has no significance.</p> <p>= 1: A linear encoder is connected \$MA_SAFE_ENC_GRID_POINT_DIST is used to specify its resolution. MD: \$MA_SAFE_ENC_RESOL, \$MA_SAFE_ENC_GEAR_PITCH, \$MA_SAFE_ENC_GEAR_DENOM[n] and \$MA_SAFE_ENC_GEAR_NUMERA[n] have no significance.</p>		
corresponds with...	<p>For 0: \$MA_SAFE_ENC_RESOL \$MA_SAFE_ENC_GEAR_PITCH \$MA_SAFE_ENC_GEAR_DENOM[n] \$MA_SAFE_ENC_GEAR_NUMERA[n]</p> <p>For 1: \$MA_SAFE_ENC_GRID_POINT_DIST</p>		

36917	\$MA_SAFE_ENC_GRID_POINT_DIST		
MD number	Grid spacing, linear scale		
Standard value: 0.01	Min. input limit: 0.000 01	Max. input limit: 8	
Change becomes effective after: Power on	Protective stage: 7/2	Units: mm	
Data type: DOUBLE	applies from SW release: 3.4		
Meaning:	This MD specifies the grid spacing of the linear scale used here. Not relevant for rotary encoders.		
corresponds with...			

36918	\$MA_SAFE_ENC_RESOL		
MD number	Encoder pulses per revolution		
Standard value: 2 048	Min. input limit: 1	Max. input limit: 100 000	
Change becomes effective after: Power on	Protective stage: 7/2	Units: –	
Data type: DWORD	applies from SW release: 3.4		
Meaning:	This MD specifies the number of pulses per revolution for a rotary encoder. Not relevant for linear encoders.		
corresponds with...			

6.1 Machine data for SINUMERIK 840D

36920	\$MA_SAFE_ENC_GEAR_PITCH		
MD number	Leadscrew pitch		
Standard value: 10	Min. input limit: 0.1	Max. input limit: 10 000	
Change becomes effective after: Power on	Protective stage: 7/2	Units: mm	
Data type: DOUBLE	applies from SW release: 3.4		
Meaning:	Gear ratio of the gearbox (gear) between the encoder and load for a linear axis with rotary encoder.		
corresponds with...			

36921	\$MA_SAFE_ENC_GEAR_DENOM[n]		
MD number	Denominator, gearbox ratio encoder/load		
Standard value: 1	Min. input limit: 1	Max. input limit: 2 147 000 000	
Change becomes effective after: Power on	Protective stage: 7/2	Units: –	
Data type: DWORD	applies from SW release: 3.4		
Meaning:	Denominator of the gearbox ratio between the encoder and load, i.e. the denominator of the fraction, number of encoder revolutions/number of load revolutions n= 0, 1, ... ,7 stands for gearbox stages 1, 2, ... 8 The actual value is selected using safety-related input signals (SGE).		
corresponds with...	MD 36922: \$MA_SAFE_ENC_GEAR_NUMERA[n]		

36922	\$MA_SAFE_ENC_GEAR_NUMERA[n]		
MD number	Numerator, gearbox ratio encoder/load		
Standard value: 1	Min. input limit: 1	Max. input limit: 2 147 000 000	
Change becomes effective after: Power on	Protective stage: 7/2	Units: –	
Data type: DWORD	applies from SW release: 3.4		
Meaning:	Numerator of the gearbox ratio between the encoder and load, i.e. the numerator of the fraction number of encoder revolutions/number of load revolutions n= 0, 1, ... 7 stands for gearbox stages 1, 2, ... 8 The actual value is selected using safety-related input signals (SGE).		
corresponds with...	MD 36921: \$MA_SAFE_ENC_GEAR_DENOM[n]		

36925	\$MA_SAFE_ENC_POLARITY		
MD number	Direction of rotation reversal actual value		
Standard value: 1	Min. input limit: –1	Max. input limit: 1	
Change becomes effective after: Power on	Protective stage: 7/2	Units: –	
Data type: DWORD	applies from SW release: 3.4		
Meaning:	Using this data, the direction of the actual value can be reversed. = –1: Direction of rotation reversal = 0 or = 1: no direction reversal		
corresponds with...			

6.1 Machine data for SINUMERIK 840D

36926	\$MA_SAFE_ENC_FREQ_LIMIT		
MD number	Encoder frequency for safe operation		
Standard value: 300000	Min. input limit: 300000	Max. input limit: 420000	
Change becomes effective after: Power on	Protective stage: 7/2	Units: freq	
Data type: DWORD	applies from SW release: 6.3		
Meaning:	Encoder frequency above which amplitude monitoring is disabled. A speed corresponding to this frequency may not be exceeded in safe operation. (SBH or SG) – the stop response parameterized for the active monitoring function is triggered. This frequency can only be set greater than 300 kHz for Performance 2 control groups. Parameterization errors are flagged with Alarm 27033.		
corresponds with...			

36930	\$MA_SAFE_STANDSTILL_TOL		
MD number	Standstill tolerance		
Standard value: 1	Min. input limit: 0	Max. input limit: 100	
Change becomes effective after: Power on	Protective stage: 7/2	Units: mm, degrees	
Data type: DOUBLE	applies from SW release: 3.4		
Meaning:	This MD specifies the tolerance for a safe operating stop. If the difference between the position reference value and position actual value is greater than the tolerance set here when a safe operating stop is selected, then the control system outputs Alarm 27010 with STOP A/B. The position limit value is the position actual value at the instant that a safe operating stop is selected.		
corresponds with...	MD 36956: \$MA_SAFE_PULSE_DISABLE_DELAY		

36931	\$MA_SAFE_VELO_LIMIT[n]		
MD number	Limit value for safely-reduced speed		
Standard value: 2000	Min. input limit: –	Max. input limit: –	
Change becomes effective after: Power on	Protective stage: 7/2	Units: mm/min, rev/min	
Data type: DOUBLE	applies from SW release: 3.4		
Meaning:	This MD defines the limit values for safely-reduced speeds 1, 2, 3 and 4. When SG1, SG2, SG3 or SG4 is selected and the actual speed exceeds this limit value, then the control system outputs Alarm 27011 with the stop response configured in \$MA_SAFE_VELO_STOP_MODE. n = 0, 1, 2, 3 stands for the limit value of SG1, SG2, SG3, SG4		
Special cases, errors,...	When SBH/SG is active and a 1–encoder system is being used, the speed is monitored corresponding to an encoder limit frequency of 200 kHz (300 kHz from SW4.2 onwards). An appropriate alarm is output if this limit is exceeded.		
corresponds with...	MD 36961: \$MA_SAFE_VELO_STOP_MODE		

6.1 Machine data for SINUMERIK 840D

36932	\$MA_SAFE_VELO_OVR_FACTOR[n]		
MD number	Override factor for SG		
Standard value: 100	Min. input limit: 1	Max. input limit: 100	
Change becomes effective after: Power on	Protective stage: 7/2	Units: %	
Data type: DWORD	applies from SW release: 4.2		
Meaning:	An override can be selected using SGEs for the limit value of the safely-reduced speeds 2 and 4 – and the associated override value (percentage) can be set using this MD. n = 0, 1, ..., 15 stands for override 0, 1, ..., 15		
Special cases, errors,...	<ul style="list-style-type: none"> The function "override, safely-reduced speed" is enabled using MD 36901 (MD 1301): \$MA(\$MD)_SAFE_FUNCTION_ENABLE This override has no effect for the limit values associated with safely-reduced speeds 1 and 3. 		
Additional references	MD 36978: \$MA_SAFE_OVR_INPUT[n] MD 36931: \$MA_SAFE_VELO_LIMIT[n]		
Meaning:	Refer to Chapter 5.5.4: "Override for safely-reduced speed"		

36933	\$MA_SAFE_DES_VELO_LIMIT		
MD number	Evaluation factor to limit the speed setpoint		
Standard value: 0	Min. input limit: 0	Max. input limit: 100	
Change becomes effective after: RESET	Protective stage: 7/2	Units: %	
Data type: DWORD	applies from SW release: 5.2		
Meaning:	This is an evaluation factor to define the setpoint limit from the actual speed limit. The active SG limit value is evaluated using this factor and is entered into the interpolator as setpoint limit. When SBH is selected, a setpoint of 0 is entered. When 100 % is entered, the setpoint is limited to the active SG stage When 0 % is entered the setpoint speed limiting is not active.		
corresponds with...			
Special cases, errors,...	This MD may have to be altered several times before an optimum setting for the dynamic response of the drives is found. To prevent this procedure from being unnecessarily awkward, "reset" has been defined as the activation criterion. This data is not included in the crosswise data comparison with the drive. This data is not included in the axial checksum \$MA_SAFE_ACT_CHECKSUM, as it is a single-channel function.		
Additional references	Refer to Chapter : 9.1"Limiting the setpoint speed"		

6.1 Machine data for SINUMERIK 840D

36934	\$MA_SAFE_POS_LIMIT_PLUS[n]		
MD number	Upper limit value for safe limit position		
Standard value: 100 000	Min. input limit: -2 147 000	Max. input limit: 2 147 000	
Change becomes effective after: Power on	Protective stage: 7/2	Units: mm, degrees	
Data type: DOUBLE	applies from SW release: 3.4		
Meaning:	This MD specifies the upper limit value for safe end positions 1 and 2. When SE1 or SE2 is selected and the actual position exceeds this limit, then the control system outputs Alarm 27012 with the stop response configured in \$MA_SAFE_POS_STOP_MODE and changes over into the SBH mode. If SBH is violated, STOP B and A are initiated as stop response. n = 0, 1 stand for the upper limit value of SE1, SE2		
corresponds with...	MD 36962: \$MA_SAFE_POS_STOP_MODE MD 36935: \$MA_SAFE_POS_LIMIT_MINUS[n] MD 36901: \$MA_SAFE_FUNCTION_ENABLE		
Special cases, errors,...	If a lower or identical value is entered in MD \$MD_SAFE_POS_LIMIT_PLUS[n] than in MD \$MA_SAFE_POS_LIMIT_MINUS[n], then a parameterizing error is displayed.		

36935	\$MA_SAFE_POS_LIMIT_MINUS[n]		
MD number	Lower limit value for safe limit position		
Standard value: -100 000	Min. input limit: -2 147 000	Max. input limit: 2 147 000	
Change becomes effective after: Power on	Protective stage: 7/2	Units: mm, degrees	
Data type: DOUBLE	applies from SW release: 3.4		
Meaning:	This MD specifies the lower limit value for safe end positions 1 and 2. When SE1 or SE2 is selected and the actual position is less than this limit value, then the control system outputs Alarm 27012 with the stop response configured in \$MA_SAFE_POS_STOP_MODE and changes over into the SBH mode. If SBH is violated, STOP B and A are initiated as stop response. n = 0, 1 stand for the lower limit value of SE1, SE2		
corresponds with...	MD 36962: \$MA_SAFE_POS_STOP_MODE MD 36934: \$MA_SAFE_POS_LIMIT_PLUS[n] MD 36901: \$MA_SAFE_FUNCTION_ENABLE		
Special cases, errors,...	If a lower or identical value is entered in MD \$MD_SAFE_POS_LIMIT_PLUS[n] than in MD \$MA_SAFE_POS_LIMIT_MINUS[n], then a parameterizing error is displayed.		

36936	\$MA_SAFE_CAM_POS_PLUS[n]		
MD number	Plus cams position for safe cams		
Standard value: 10	Min. input limit: -2 147 000	Max. input limit: 2 147 000	
Change becomes effective after: Power on	Protective stage: 7/2	Units: mm, degrees	
Data type: DOUBLE	applies from SW release: 3.4		
Meaning:	This MD specifies the plus cam position for safe cams SN1+, SN2+, SN3+ and SN4+. If the actual position is greater than this value when the safe cam function is active, then the appropriate safety-relevant output signal (SGA) is set to 1. If the actual position falls below this value, SGA is set to 0. n = 0, 1, 2, 3 stand for the plus cam position of SN1+, SN2+, SN3+, SN4+		
corresponds with...	MD 36988: \$MA_SAFE_CAM_PLUS_OUTPUT[n] MD 36901: \$MA_SAFE_FUNCTION_ENABLE		

6.1 Machine data for SINUMERIK 840D

36937	\$MA_SAFE_CAM_POS_MINUS[n]		
MD number	Minus cams position for safe cams		
Standard value: -10	Min. input limit: -2 147 000	Max. input limit: 2 147 000	
Change becomes effective after: Power on	Protective stage: 7/2	Units: mm, degrees	
Data type: DOUBLE	applies from SW release: 3.4		
Meaning:	This MD specifies the minus cam position for safe cams SN1-, SN2-, SN3- and SN4-. If the actual position is \leq this value when the safe cam function is active, then the appropriate safety-relevant output signal (SGA) is set to 1. If the actual position falls below this value, SGA is set to 0. n = 0, 1, 2, 3 stand for the minus cam position of SN1 -, SN2 -, SN3 -, SN4 -		
corresponds with...	MD 36989: \$MA_SAFE_CAM_MINUS_OUTPUT[n]MD 36901: \$MA_SAFE_FUNCTION_ENABLE		

36940	\$MA_SAFE_CAM_TOL		
MD number	Tolerance for safe cams		
Standard value: 0.1	Min. input limit: 0.001	Max. input limit: 10	
Change becomes effective after: Power on	Protective stage:	Units: mm, degrees	
Data type: DOUBLE	applies from SW release: 3.4		
Meaning:	Due to the different mounting locations of the encoders and variations in clock cycle and signal transit (propagation times), the cam signals of the two monitoring channels never switch at precisely the same position and never simultaneously. This data specifies the tolerances for all cams as a load-side distance. The monitoring channels may have different signal states for the same cam within this tolerance bandwidth without generating Alarm 27001. Recommendation: Enter an identical or slightly higher value than that set in MD 36942.		
Special cases, errors,...			

36942	\$MA_SAFE_POS_TOL		
MD number	Tolerance, actual value comparison (crosswise)		
Standard value: 0.1	Min. input limit: 0.001	Max. input limit: 360 degrees	
Change becomes effective after: Power on	Protective stage: 7/2	Units: mm, degrees	
Data type: DOUBLE	applies from SW release: 3.4		
Meaning:	Due to the fact that encoders are not mounted at identical locations and the effect of backlash, torsion, leadscrew errors etc. the actual positions sensed simultaneously by the NCK and drive may differ from one another. The tolerance bandwidth for the crosswise comparison of the actual positions in the two monitoring channels is specified in this machine data.		
Special cases, errors,...	<ul style="list-style-type: none"> "Finger protection" (approx. 10 mm) is the primary consideration when setting this tolerance value. Stop response STOP F is activated when the tolerance bandwidth is violated. 		

6.1 Machine data for SINUMERIK 840D

36944	\$MA_SAFE_REFP_POS_TOL		
MD number	Tolerance, actual value comparison (referencing)		
Standard value: 0.01	Min. input limit: 0	Max. input limit: 36 degrees	
Change becomes effective after: Power on	Protective stage: 7/2	Units: mm, degrees	
Data type: DOUBLE	applies from SW release: 3.4		
Meaning:	<p>This machine data specifies the tolerance for checking the actual values after referencing (for incremental encoders) or when powering-up (for absolute encoders). A second absolute actual position is calculated from the last standstill position that was saved prior to the control being powered-down and the distance traversed since power-on. The control system checks the actual values after referencing on the basis of the two actual positions, the traversed distance and this machine data.</p> <p>The following factors must be taken into consideration when calculating tolerance values: Backlash, leadscrew errors, compensation (max. compensation values for SSK, sag and temperature compensation), temperature errors, torsion (2-encoder system), gearbox play for selector gearboxes, coarser resolution (2-encoder system), oscillating distance/range for selector gearboxes.</p>		
Special cases, errors,...	If these two actual positions deviate from one another by more than the value set in this data – with a valid user agreement – then Alarm 27001 is output with Fault code 1003 and a new user agreement is required for referencing.		

36946	\$MA_SAFE_VELO_X		
MD number	Speed limit n_x		
Standard value: 20.0	Min. input limit: 0.0	Max. input limit: 1 000.0	
Change becomes effective after: Power on	Protective stage: 7/2	Units: mm/min, rev/min	
Data type: DOUBLE	applies from SW release: 4.2		
Meaning:	This machine data defines the limit speed n_x for the SGA "n < n_x ". If this velocity limit is fallen below, SGA "n < n_x " is set.		
corresponds with...	MD 1346: \$MD_SAFE_VELO_X		
Additional references	Refer to Chapter 3: "SGA "n < n_x " and "SG active""		

36948	\$MA_SAFE_STOP_VELO_TOL		
MD number	Velocity tolerance for the safe braking ramp.		
Standard value: 300.0	Min. input limit: 0.0	Max. input limit: 20 000.0	
Change becomes effective after: Power on	Protective stage: 7/2	Units: mm/min, rev/min	
Data type: DOUBLE	applies from SW release: 4.2		
Meaning:	<p>Tolerance actual velocity for the safe braking ramp (SBR). After the safe braking ramp has been activated (by initiating a Stop B or C), then this tolerance is applied.</p> <p>It is not permissible that the actual velocity is greater than the limit that is therefore specified. Otherwise, a STOP A will be initiated. This means that if the drive accelerates, this will be identified very quickly.</p>		
corresponds with...	MD 1348: \$MD_SAFE_STOP_VELO_TOL		
Additional references	Refer to Chapter 5.8: "Safe braking ramp (SBR)" (a recommended setting and setting formula are specified in this Chapter).		

6.1 Machine data for SINUMERIK 840D

36949	\$MA_SAFE_SLIP_VELO_TOL		
MD number	Speed tolerance, slip		
Standard value: 6.0	Min. input limit: 0.	Max. input limit: 6000.0	
Change becomes effective after: Power on	Protective stage: 7/2	Units: mm/min, rev/min	
Data type: DOUBLE	applies from SW release: 5.2		
Meaning:	Speed difference that, for a 2–encoder system, is tolerated between the drive and load sides without the crosswise data comparison between SIMODRIVE 611 digital and NCK signaling an error. MD 36949 is only evaluated if MD \$MA_SAFE_FUNCTION_ENABLE, bit 3 is set.		
corresponds with...	MD 1349: \$MD_SAFE_SLIP_VELO_TOL		
Additional references	Refer to Chapter 4.4: Actual value conditioning		

36950	\$MA_SAFE_MODE_SWITCH_TIME		
MD number	Tolerance time for SGE changeover		
Standard value: 0.5	Min. input limit: 0	Max. input limit: 10	
Change becomes effective after: Power on	Protective stage: 7/2	Units: s	
Data type: DOUBLE	applies from SW release: 3.4		
Meaning:	SGE changeover operations do not take effect simultaneously owing to variations in run times (propagation times) for SGE data transmission in the two monitoring channels. A crosswise data comparison would, in this case, output an error message. This data is used to specify the period of time after SGE changeover operations during which no crosswise comparison of actual values and monitoring results is carried–out (machine data is still compared!). The selected monitoring functions continue to operate unhindered in both monitoring channels. A safety–related function is immediately activated in a monitoring channel if selection or changeover is detected in this channel. The different run time (propagation time) is mainly caused by the PLC cycle time.		
Special cases, errors,...	System–related minimum tolerance time 2 x PLC cycle time (maximum cycle) + 1 x IPO cycle time The variations in the run times in the external circuitry (e.g. relay operating times) must also be taken into account.		
Additional references	Refer to Chapter 5.9: "safety–related input/output signals (SGE/SGA)"		

6.1 Machine data for SINUMERIK 840D

36951	\$MA_SAFE_VELO_SWITCH_DELAY		
MD number	Delay time, speed changeover		
Standard value: 0.1	Min. input limit: 0	Max. input limit: 60	
Change becomes effective after: Power on	Protective stage: 7/2	Units: s	
Data type: DOUBLE	applies from SW release: 3.4		
Meaning:	<p>A timer with this value is started when changing from a high to a lower safely-reduced speed – or when a safe operating stop is selected when the safely-reduced speed function is active.</p> <p>The parameterized value must be selected as low as possible.</p> <p>While the timer is running, the speed continues to be monitored against the last selected speed limit value. During this period, the axis/spindle can be braked, for example, from the PLC user program, without the monitoring function signaling an error and initiating a stop response.</p>		
Special cases, errors,...	<p>Examples:</p> <ol style="list-style-type: none"> 1. The timer is immediately interrupted as soon as a higher or identical SG limit (i.e. to that which was previously active) is selected. 2. The timer is immediately interrupted if "non-safe operation" (= NSB SGE "de-select SBH/SG=1) is selected. 3. The timer is re-triggered (restarted) if, while the timer is running, a changeover is made to a lower SG limit than was previously active or to SBH. 		
corresponds with...			

36952	\$MA_SAFE_STOP_SWITCH_TIME_C		
MD number	Transition time, STOP C to safe operating stop		
Standard value: 0.1	Min. input limit: 0	Max. input limit: 10	
Change becomes effective after: Power on	Protective stage: 7/2	Units: s	
Data type: DOUBLE	applies from SW release: 3.4		
Meaning:	<p>This machine data defines the time period between the initiation of a STOP C and the activation of a safe operating stop.</p> <p>After the time has expired, the drive is monitored for a safe operating stop. If the axis/spindle was still not able to be stopped, STOP B/A is initiated.</p> <p>The parameterized value must be selected as low as possible.</p>		
corresponds with...			

36953	\$MA_SAFE_STOP_SWITCH_TIME_D		
MD number	Transition time, STOP D to safe operating stop		
Standard value: 0.1	Min. input limit: 0	Max. input limit: 60	
Change becomes effective after: Power on	Protective stage: /2	Units: s	
Data type: DOUBLE	applies from SW release: 3.4		
Meaning:	<p>This machine data defines the time period between the initiation of a STOP D and the activation of a safe operating stop.</p> <p>After the time has expired, the drive is monitored for a safe operating stop. If the axis/spindle was still not able to be stopped, STOP B/A is initiated.</p> <p>The parameterized value must be selected as low as possible.</p>		
corresponds with...			

6.1 Machine data for SINUMERIK 840D

36954	\$MA_SAFE_STOP_SWITCH_TIME_E		
MD number	Transition time, STOP E to safe standstill		
Standard value: 0.1	Min. input limit: 0	Max. input limit: 60	
Change becomes effective after: Power on	Protective stage: 7/2	Units:	
Data type: DOUBLE	applies from SW release: 6.4.15		
Meaning:	Time after which a changeover is made from STOP E to a safe operating stop. The parameterized value must be selected as low as possible.		
Special cases, errors,...			
corresponds with...			

36955	\$MA_SAFE_STOP_SWITCH_TIME_F		
MD number	Transition time STOP F to STOP B		
Standard value: 0	Min. input limit: 0	Max. input limit: 60	
Change becomes effective after: Power on	Protective stage: 7/2	Units:	
Data type: DOUBLE	applies from SW release: 6.4.09		
Meaning:	Time after which, for a STOP F with active monitoring functions, a change is made to STOP B. The changeover is also made if a STOP C/D/E occurs during this time. The parameterized value must be selected as low as possible.		
Special cases, errors,...			
corresponds with...			

36956	\$MA_SAFE_PULSE_DISABLE_DELAY		
MD number	Delay time, pulse cancellation		
Standard value: 0.1	Min. input limit: 0	Max. input limit: 10	
Change becomes effective after: POWER ON	Protective stage: 7/2	Units: s	
Data type:	applies from SW release:		
Meaning:	For a STOP B, the axis is braked along the current limit with speed setpoint 0. After the delay time defined in this data, the braking mode changes to STOP A for pulse cancellation. The parameterized value must be selected as low as possible.		
Special cases, errors,...	The pulses are cancelled earlier than defined in this machine data if the condition for the pulse cancellation is present via MD 36960: \$MA_SAFE_STANDSTILL_VELO_TOL or MD 36620: \$MA_SERVO_DISABLE_DELAY_TIME. If the timer in this machine data is set to zero, then an immediate transition is made from STOP B to a STOP A (immediate pulse cancellation).		
corresponds with...	MD 36960: \$MA_SAFE_STANDSTILL_VELO_TOL MD 36620: \$MA_SERVO_DISABLE_DELAY_TIME MD 36060: \$MA_STANDSTILL_VELO_TOL		

6.1 Machine data for SINUMERIK 840D

36957	\$MA_SAFE_PULSE_DIS_CHECK_TIME		
MD number	Time to check pulse cancellation		
Standard value: 0.1	Min. input limit: 0	Max. input limit: 10	
Change becomes effective after: Power on	Protective stage: 7/2	Units: s	
Data type: DOUBLE	applies from SW release: 3.4		
Meaning:	This machine data specifies the time when, after pulse cancellation has been requested, the pulses must be actually cancelled. The time that elapses between setting the SGA "enable pulses" and detecting the SGE "pulses cancelled status" may not exceed the time limit set in this data.		
Special cases, errors,...	If this time is exceeded, a STOP A is initiated.		

36958	\$MA_SAFE_ACCEPTANCE_TST_TIMEOUT		
MD number	Time limit for the acceptance test duration		
Standard value: 40	Min. input limit: 5	Max. input limit: 100	
Change becomes effective after: Power on	Protective stage: 7/2	Units: s	
Data type: DOUBLE	applies from SW release: 6.4		
Meaning:	On the NCK side, a time limit can be entered for the duration of an acceptance test. If an acceptance test takes longer than the time specified in MD 36958, then the NCK terminates the test. The acceptance status is set to zero on the NCK side. If the acceptance test has been reset, then on the NCK and drive sides, SI power on alarms are again changed over from being able to be acknowledged with a reset to being able to be acknowledged with power on. NCK clears Alarm 27007 and the drive clears Alarm 300952. This MD is also used to limit the duration of an acceptance test SE. After the programmed time has expired, the acceptance test SE is interrupted and Alarm 27008 is cleared. The software limit positions are then again effective – the same as they are entered in the machine data.		
corresponds with...			

36960	\$MA_SAFE_STANDSTILL_VELO_TOL		
MD number	Shutdown speed, pulse cancellation		
Standard value: 0	Min. input limit: 0	Max. input limit: 6 000	
Change becomes effective after: Power on	Protective stage: 7/2	Units: mm/min, rev/min	
Data type: DOUBLE	applies from SW release: 3.4		
Meaning:	When the axis/spindle speed drops below this limit, it is considered to be at a "standstill". In the STOP B mode the pulses are then cancelled (as a result of the transition to STOP A).		
corresponds with...	MD 36956: \$MA_SAFE_PULSE_DISABLE_DELAY		

6.1 Machine data for SINUMERIK 840D

36961	\$MA_SAFE_VELO_STOP_MODE		
MD number	Stop response, safely-reduced speed		
Standard value: 5	Min. input limit: 0	Max. input limit: 14	
Change becomes effective after: Power on	Protective stage: 7/2	Units: –	
Data type: BYTE	applies from SW release: 3.4		
Meaning:	<p>The stop response programmed in this machine data is initiated if a limit value for safely-reduced speed 1, 2, 3 or 4 is exceeded.</p> <p>The ones position defines the selection of the stop response when the safely-reduced speed is exceeded.</p> <p>The tens position defines the behavior when the drive bus fails if a time greater than 0 was parameterized in \$MN_SAFE_PULSE_DIS_TIME_BUSFAIL.</p> <p>=0: Stop A =1: Stop B =2: Stop C =3: Stop D =4: Stop E =5: SAFE_VELO_STOP_MODE not valid – the stop response is parameterized using MD SAFE_VELO_STOP_REACTION =10: Stop A, in addition when the drive bus fails and SG is active, the pulses are not immediately cancelled =11: Stop B, in addition when the drive bus fails and SG is active, the pulses are not immediately cancelled =12: Stop C, in addition when the drive bus fails and SG is active, the pulses are not immediately cancelled =13: Stop D, in addition when the drive bus fails and SG is active, the pulses are not immediately cancelled =14: Stop E, in addition when the drive bus fails and SG is active, the pulses are not immediately cancelled</p>		
Special cases, errors,...			
corresponds with...	MD 36931: \$MA_SAFE_VELO_LIMIT[n] MD 36963: \$MA_SAFE_VELO_STOP_REACTION[n]		

36962	\$MA_SAFE_POS_STOP_MODE		
MD number	Stop response, safe limit position		
Standard value: 2	Min. input limit: 2	Max. input limit: 3	
Change becomes effective after: Power on	Protective stage: 7/2	Units: –	
Data type: BYTE	applies from SW release: 3.4		
Meaning:	<p>This machine data selects the stop response when passing the safe limit position.</p> <p>2: STOP C 3 STOP D 4 STOP E</p>		
corresponds with...	MD 36934: \$MA_SAFE_POS_LIMIT_PLUS[n] MD 36935: \$MA_SAFE_POS_LIMIT_MINUS[n]		

6.1 Machine data for SINUMERIK 840D

36963	\$MA_SAFE_VELO_STOP_REACTION[n]: 0 ... 3		
MD number	Stop response, safely-reduced speed		
Standard value: 2	Min. input limit: 0	Max. input limit: 3	
Change becomes effective after: Power on	Protective stage: 7/2	Units: –	
Data type: BYTE	applies from SW release: 4.2		
Meaning:	<p>The stop response programmed in this machine data is initiated if a limit value for safely-reduced speed 1, 2, 3 or 4 is exceeded. n = 0, 1, 2, 3 stands for SG1, SG2, SG3, SG4. The ones position defines the SG-specific selection of the stop response when the safely-reduced speed is exceeded. The tens position defines the behavior when the drive bus fails on an SG-specific basis if a time greater than 0 was parameterized in \$MN_SAFE_PULSE_DIS_TIME_BUSFAIL.</p> <p>0: Stop A 1: Stop B 2: Stop C 3: Stop D 4: Stop E</p> <p>10: Stop A, in addition, when the drive bus fails, the pulses are not immediately cancelled if this SG stage is active. 11: Stop B, in addition, when the drive bus fails, the pulses are not immediately cancelled if this SG stage is active. 12: Stop C, in addition, when the drive bus fails, the pulses are not immediately cancelled if this SG stage is active. 13: Stop D, in addition, when the drive bus fails, the pulses are not immediately cancelled if this SG stage is active. 14: Stop E, in addition, when the drive bus fails, the pulses are not immediately cancelled if this SG stage is active.</p>		
Special cases, errors,...	This function is only active when MD 36961 and MD 1361 have the value 5.		
corresponds with...	MD 36931: \$MA_SAFE_VELO_LIMIT[n] MD 36961: \$MA_SAFE_VELO_STOP_MODE		

6.1 Machine data for SINUMERIK 840D

36964	\$MA_SAFE_IPO_STOP_GROUP		
MD number	Grouping, safety IPO response		
Standard value: 0	Min. input limit: 0	Max. input limit: 1	
Change becomes effective after: RESET	Protective stage: 7/2	Units: –	
Data type: BYTE	applies from SW release: 4.4.18		
Meaning:	<p>This MD is only effective for Safety Integrated axes/spindles. It influences the channel-wide IPO stop response distribution of Safety Integrated.</p> <p>0 = All other axes/spindles in the channel are notified of the IPO stop response of this axis (default setting)</p> <p>1 = For internal STOPs, the axes and machining spindles, interpolating with the axis involved, are also additionally influenced via the initiated safety alarms. On the other hand, other axes/spindles in the channel continue to operate without any disturbance.</p> <p>For external STOPs (without alarm) all of the other axes/spindles remain unaffected by the safety axis/spindle stop. This allows, for example, the pulses of the spindle to be safely cancelled (using an external STOP A). This means that the spindle can be manually rotated and the axes can still be safely monitored while it is moving.</p> <p>If, in some machining situations, the other axes/spindles should stop together with the safety axis/spindle, then the user is responsible in implementing this using PLC or synchronous action logic combinations.</p>		
corresponds with...			

36965	\$MA_SAFE_PARK_ALARM_SUPPRESS		
MD number	Alarm suppression for parking axis		
Standard value: FALSE	Min. input limit: –	Max. input limit: –	
Change becomes effective after: Power on	Protective stage: 7/2	Units: –	
Data type: BOOLEAN	applies from SW release: 5.2		
Meaning:	<p>This MD is only effective for Safety Integrated axes/spindles. This MD data enables the suppression of Alarms 27000/300950 "Axis not safely referenced" when the "parking" function is selected.</p>		
corresponds with...			

36966	\$MA_SAFE_BRAKETEST_TORQUE		
MD number	Holding torque, brake test		
Standard value: 5	Min. input limit: 0	Max. input limit: 800	
Change becomes effective after: Power on	Protective stage: 7/2	Units: %	
Data type: DOUBLE	applies from SW release: 6.3.21		
Meaning:	<p>This MD specifies the torque or force when testing the mechanical brake system. The holding brake must be capable of applying this torque without any axis slippage.</p> <p>Activating the appropriate test function via MD \$MA_FIXED_STOP_MODE, bit 1. This MD must be a minimum of 10 % above the actual torque when selecting the brake test (i.e. with the brake open). This guarantees that if the brake is defective, the motor can again brake the axis. If this is not the case, the brake test is aborted with Alarm 20095.</p> <p>If the drive MD 1192 is not correctly parameterized, then the required safety margin is increased by twice the margin between the real torque and that parameterized in MD 1192.</p>		

6.1 Machine data for SINUMERIK 840D

36967	\$MA_BRAKETEST_POS_TOL		
MD number	Position tolerance, brake test		
Standard value: 1	Min. input limit: 0	Max. input limit: –	
Change becomes effective after: Power on	Protective stage: 7/2	Units: mm/degrees	
Data type: DOUBLE	applies from SW release: 6.3.21		
Meaning:	Maximum position tolerance when testing the mechanical brake system. If the axis position deviates from the position by more than this tolerance, when the brake test is selected, then the brake test is aborted. The corresponding test function is enabled using MD \$MA_FIXED_STOP_MODE, bit 1		

36968	\$MA_SAFE_BRAKETEST_CONTROL		
MD number	Sequence check, brake test		
Standard value: 0	Min. input limit: 0	Max. input limit: 1	
Change becomes effective after: Power on	Protective stage: 7/2	Units: –	
Data type: DWORD	applies from SW release: 6.05.11		
Meaning:	Bit 0: 0: The drive MD 1192 is used as average value of the torque limit 1: The measured torque at the instant in time that the brake test is selected is used as the average value of the torque limit.		

Note

The maximum input value for all axial NCK_SGE/SGA configured machine data differs depending on the particular application::

Configuring at the NCK I/O: 811E0810

Configuring an SGE at the SPL interface: 84020220

Configuring an SGA at the SPL interface: 84010220

An incorrect entry will be detected at the next run-up and flagged using Alarm 27033.

Description of the parameterization of the SGE machine data MD 36970 to MD 36979

Coding of the input assignment

Structure of the input assignment, SBH/SG de-selection

is	mm	xx	nn	Permissible values	Explanation
i	Inversion			0, 8	0: No inversion 8: Inversion before processing
s	Segment No.			0, 1, 4	1: I/O at the 611 digital bus (terminal) 4: Internal image in the system memory (system variable)

6.1 Machine data for SINUMERIK 840D

Additional parameterization, if a terminal is assigned (s = 1).

mm	Module No.	01–1F	Number of the logical slot in which the terminal block with the external I/O is inserted (drive number)
xx	Sub–module No.	01–08	Slot number of the sub–module within the I/O module
nn	I/O No.	01–10	Bit number (input/output number on the sub–module)

Additional parameterization if a system variable is assigned (s = 4).

mm	Module No.	01–02	01: Addressing the internal SPL interface \$A_OUTSI or \$A_INSI 02: Addressing the external SPL interface (only for input signals, \$A_INSE)
xx	Sub–module No.	01–02	Index of the system variable word (each 32 bit)
nn	I/O No.	01–20	Bit number in the system variable word \$A_OUTSID[xx], \$A_INSID[xx], \$A_INSED[xx]

Additional parameterization for local inputs on the NCU (from SW 6.3.21): (s = 0)

mm	=00H	Fixed
xx	=00H	Fixed
nn	=01H–04H	Bit number

An individual bit is "connected" to a terminal with each entry. The structure corresponds to MD 10362: \$MN_HW_ASSIGN_ANA_FASTIN[n].

6.1 Machine data for SINUMERIK 840D

36970	\$MA_SAFE_SVSS_DISABLE_INPUT								
MD number	Input assignment, SBH/SG de-selection								
Standard value: 0	Min. input limit: 0	Max. input limit: –							
Change becomes effective after: Power on	Protective stage: 7/2	Units: –							
Data type: DWORD	applies from SW release: 3.4								
Meaning:	This machine data defines the NCK input to select/de-select the SBH and SG functions								
Structure:	<table border="0"> <tr> <td>Signal</td> <td>Means</td> </tr> <tr> <td>= 0</td> <td>SG or SBH is selected</td> </tr> <tr> <td>= 1</td> <td>SG and SBH are de-selected</td> </tr> </table>			Signal	Means	= 0	SG or SBH is selected	= 1	SG and SBH are de-selected
Signal	Means								
= 0	SG or SBH is selected								
= 1	SG and SBH are de-selected								
Special cases, errors,...	<ul style="list-style-type: none"> Input value of 0 means: There is no assignment, the input remains fixed at 0, SG and SBH cannot be de-selected Input value of 80 00 00 00 means: There is no assignment, the input remains fixed at 1 If MD bit 31 is set, then the signal is processed inverted (ss = 81). 								
Additional references	/								
corresponds with...	MD 10366: \$MN_HW_ASSIGN_DIG_FASTIN MD 13010: \$MN_DRIVE_LOGIC_NR								

36971	\$MA_SAFE_SS_DISABLE_INPUT		
MD number	Input assignment, SBH de-selection		
Standard value: 0	Min. input limit: 0	Max. input limit: –	
Change becomes effective after: Power on	Protective stage: 7/2	Units: –	
Data type: DWORD	applies from SW release: 3.4		
Meaning:	Assignment of the NCK input to de-select the safe operating stop function.		
Structure:	Refer to the coding of the input assignment		
Assignment of the terminal signal level to the safe functions if safely-reduced speed or safe operating stop has been activated.			
Signal	Means		
= 0	Safe operating stop is selected		
= 1	Safe operating stop is de-selected (only if STOP C, D or E has not been activated by other functions)		
Special cases, errors,...	<ul style="list-style-type: none"> If MD bit 31 is set, then the signal is processed inverted (ss = 81). This input is of no significance if SG and SBH have been de-selected (refer to \$MA_SAFE_SVSS_DISABLE_INPUT). 		
Additional references	MD 36970: \$MA_SAFE_SVSS_DISABLE_INPUT		

6.1 Machine data for SINUMERIK 840D

36972	\$MA_SAFE_VELO_SELECT_INPUT[n]: 0 ... 1																	
MD number	Input assignment, SG selection																	
Standard value: 0	Min. input limit: 0	Max. input limit: –																
Change becomes effective after: Power on	Protective stage: 7/2	Units: –																
Data type: DWORD	applies from SW release: 3.4																	
Meaning:	<p>This machine data defines the two inputs to select SG1, SG2, SG3 or SG4. Structure: Refer to the coding of the input assignment n = 1, 0 stand for bit 1, 0 to select from SG1 to SG4 Assignment of the input bits to the safely-reduced speeds:</p> <table border="1"> <thead> <tr> <th>Bit 1</th> <th>Bit 0</th> <th>Selected SG</th> </tr> </thead> <tbody> <tr> <td>0</td> <td>0</td> <td>SG1</td> </tr> <tr> <td>0</td> <td>1</td> <td>SG2</td> </tr> <tr> <td>1</td> <td>0</td> <td>SG3</td> </tr> <tr> <td>1</td> <td>1</td> <td>SG4</td> </tr> </tbody> </table>			Bit 1	Bit 0	Selected SG	0	0	SG1	0	1	SG2	1	0	SG3	1	1	SG4
Bit 1	Bit 0	Selected SG																
0	0	SG1																
0	1	SG2																
1	0	SG3																
1	1	SG4																
Special cases, errors,...	If the MD bits 31 are set, then the signal is processed inverted (ss = 81).																	
Additional references	MD 36971: \$MA_SAFE_SVSS_DISABLE_INPUT																	

36973	\$MA_SAFE_POS_SELECT_INPUT								
MD number	Input assignment, SE selection								
Standard value: 0	Min. input limit: –	Max. input limit: –							
Change becomes effective after: Power on	Protective stage: 7/2	Units: –							
Data type: DWORD	applies from SW release: 3.4								
Meaning:	<p>This machine data defines the input to select the safe limit position 1 or 2. Structure: Refer to the coding of the input assignment</p> <table border="1"> <thead> <tr> <th>Signal</th> <th>Means</th> </tr> </thead> <tbody> <tr> <td>= 0</td> <td>SE1 is active</td> </tr> <tr> <td>= 1</td> <td>SE2 is active</td> </tr> </tbody> </table>			Signal	Means	= 0	SE1 is active	= 1	SE2 is active
Signal	Means								
= 0	SE1 is active								
= 1	SE2 is active								
Special cases, errors,...	If MD bit 31 is set, then the signal is processed inverted (ss = 81).								
Additional references	MD 36970: \$MA_SAFE_SVSS_DISABLE_INPUT								

36974	\$MA_SAFE_GEAR_SELECT_INPUT[n]: 0 ... 2																											
MD number	Input assignment, gearbox ratio selection																											
Standard value: 0	Min. input limit: –	Max. input limit: –																										
Change becomes effective after: Power on	Protective stage: 7/2	Units: –																										
Data type: DWORD	applies from SW release: 3.4																											
Meaning:	<p>Assigns the input terminals to select the gearbox ratio (gearbox stage). Structure: Refer to the coding of the input assignment n= 2, 1, 0 stand for bit 2, 1, 0 to select gearbox stages 1 to 8</p> <table border="1"> <thead> <tr> <th>Bit 2</th> <th>Bit 1</th> <th>Bit 0</th> <th>Active gearbox stage</th> </tr> </thead> <tbody> <tr> <td>0</td> <td>0</td> <td>0</td> <td>Stage 1</td> </tr> <tr> <td>0</td> <td>0</td> <td>1</td> <td>Stage 2</td> </tr> <tr> <td>0</td> <td>1</td> <td>0</td> <td>Stage 3</td> </tr> <tr> <td>...</td> <td>...</td> <td>...</td> <td>...</td> </tr> <tr> <td>1</td> <td>1</td> <td>1</td> <td>Stage 8</td> </tr> </tbody> </table>				Bit 2	Bit 1	Bit 0	Active gearbox stage	0	0	0	Stage 1	0	0	1	Stage 2	0	1	0	Stage 3	1	1	1	Stage 8
Bit 2	Bit 1	Bit 0	Active gearbox stage																									
0	0	0	Stage 1																									
0	0	1	Stage 2																									
0	1	0	Stage 3																									
...																									
1	1	1	Stage 8																									
Special cases, errors,...	If the MD bits 31 are set, then the signal is processed inverted (ss = 81).																											
Additional references	MD 36970: \$MA_SAFE_SVSS_DISABLE_INPUT																											

6.1 Machine data for SINUMERIK 840D

36975	\$MA_SAFE_STOP_REQUEST_INPUT		
MD number	Input assignment, test stop selection		
Standard value: 0	Min. input limit: 0	Max. input limit: –	
Change becomes effective after: Power on	Protective stage: 7/2	Units: –	
Data type: DWORD	applies from SW release: 3.4		
Meaning:	This machine data is used to define the input to select the test stop. Structure: Refer to the coding of the input assignment Signal Means = 0 Test stop is not active = 1 Test stop is being executed		
Special cases, errors,...	If MD bit 31 is set, then the signal is processed inverted (ss = 81).		
Additional references	MD 36970: \$MA_SAFE_SVSS_DISABLE_INPUT		

36976	\$MA_SAFE_PULSE_STATUS_INPUT		
MD number	Input assignment, status pulses cancelled		
Standard value: 0	Min. input limit: 0	Max. input limit: –	
Change becomes effective after: Power on	Protective stage: 7/2	Units: –	
Data type: DWORD	applies from SW release: 3.4		
Meaning:	This machine data is used to define the input used to feed back the signal that the pulses have been cancelled. Structure: Refer to the coding of the input assignment Signal Means = 0 Pulses have been enabled = 1 Pulses have been cancelled		
Special cases, errors,...	If MD bit 31 is set, then the signal is processed inverted (ss = 81).		
Additional references	MD 36970: \$MA_SAFE_SVSS_DISABLE_INPUT		

36977	\$MA_SAFE_EXT_STOP_INPUT[n]: 0...3		
MD number	Input assignment, external brake request		
Standard value: 0	Min. input limit: –	Max. input limit: –	
Change becomes effective after: Power on	Protective stage: 7/2	Units: –	
Data type: DWORD	applies from SW release: 4.4.18		
Meaning:	Assigns the input terminal for the external brake request signals, assigns the terminal signal level to the stopping types ("0" active): Index 0: Assignment for "de-select ext. STOP A" (SH, pulse cancellation) Index 1: Assignment for "de-select ext. STOP C" (braking at the current limit) Index 2: Assignment for "de-select ext. STOP D" (braking along a path) Index 3: Assignment for "de-select ext. STOP E" (ESR, braking along a path) For safety signals, these signals use inverted logic.		
corresponds with...	MD 36970: \$MA_SAFE_SVSS_DISABLE_INPUT		
Additional references	Refer to Chapter 5.2: "External STOPs"		

6.1 Machine data for SINUMERIK 840D

36978	\$MA_SAFE_OVR_INPUT[n]: 0...3																											
MD number	Input assignment, SG override selection																											
Standard value: 0	Min. input limit: 0	Max. input limit: –																										
Change becomes effective after: Power on	Protective stage: 7/2	Units: –																										
Data type: DWORD	applies from SW release: 4.2																											
Meaning:	<p>Assigns the NCK inputs for the override of the limit value of the safely-reduced speeds 2 and 4.</p> <p>Structure: Refer to the coding of the input assignment n = 3, 2, 1, 0 stand for override selection bits 3, 2, 1, 0</p> <p>Assigns the input bits to the SG override values:</p> <table border="0"> <thead> <tr> <th>Bit 3</th> <th>Bit 2</th> <th>Bit 1</th> <th>Bit 0</th> <th></th> </tr> </thead> <tbody> <tr> <td>0</td> <td>0</td> <td>0</td> <td>0</td> <td>Override 0 is selected</td> </tr> <tr> <td>0</td> <td>0</td> <td>0</td> <td>1</td> <td>Override 1 is selected</td> </tr> <tr> <td colspan="5">to</td> </tr> <tr> <td>1</td> <td>1</td> <td>1</td> <td>1</td> <td>Override 15 is selected</td> </tr> </tbody> </table> <p>The override factor itself (percentage) is defined using the following machine data: for 840D MD 36932: \$MA_SAFE_VELO_OVR_FACTOR[n] for 611digital MD 1332: \$MD_SAFE_VELO_OVR_FACTOR[n]</p>			Bit 3	Bit 2	Bit 1	Bit 0		0	0	0	0	Override 0 is selected	0	0	0	1	Override 1 is selected	to					1	1	1	1	Override 15 is selected
Bit 3	Bit 2	Bit 1	Bit 0																									
0	0	0	0	Override 0 is selected																								
0	0	0	1	Override 1 is selected																								
to																												
1	1	1	1	Override 15 is selected																								
Special cases, errors,...	<p>The function "override, safely-reduced speed" is enabled using MD 36901 (MD 1301): \$MA(\$MD)_SAFE_FUNCTION_ENABLE, bit 5. If the MD bits 31 are set, then the signal is processed inverted (ss = 81).</p>																											
corresponds with...	<p>MD 36970: \$MA_SAFE_SVSS_DISABLE_INPUT MD 36932: \$MA_SAFE_VELO_OVR_FACTOR[n]</p>																											
Additional references	Refer to Chapter 5.5.4: "Override for safely-reduced speed"																											

6.1 Machine data for SINUMERIK 840D

36979	\$MA_SAFE_STOP_REQUEST_EXT_INPUT		
MD number	Assignment of the input terminal to select "test stop external shutdown"		
Standard value: 0	Min. input limit: 0	Max. input limit: 0x811E0810	
Change becomes effective after: RESTART	Protective stage: 7/2	Units: –	
Data type: DWORD	applies from SW release: 6.3		
Meaning:	This MD must be parameterized as soon as the internal pulse cancellation is used (bit 30 in \$MA_SAFE_PULSE_ENABLE_OUTPUT=1) Structure: Refer to the coding of the input assignment With each machine data of this kind, a single I/O bit is connected to a terminal or a system variable. Otherwise, the structure of the machine data is the same as for 36970 and onwards.		
Special cases, errors,...			
Additional references			

Description of the parameterization of the SGA machine data MD 36980 to MD 36990

Coding of the output assignment

Structure of the output assignment, SBH/SG de-selection

is	mm	xx	nn	Permissible values	Explanation
i	Inversion			0, 8	0: No inversion 8: Inversion before processing
s	Segment No.			0, 1, 4	1: I/O at the 611 digital bus (terminal) 4: Internal image in the system memory (system variable)

Additional parameterization, if a terminal is assigned (s = 1).

mm	Module No.	01–1F	Number of the logical slot in which the terminal block with the external I/O is inserted (drive number)
xx	Sub-module No.	01–08	Slot number of the sub-module within the I/O module
nn	I/O No.	01–10	Bit number (input/output number on the sub-module)

Additional parameterization if a system variable is assigned (s = 4).

mm	Module No.	01–02	01: Addressing the internal SPL interface \$A_OUTSI or \$A_INSI 02: Addressing the external SPL interface (only for input signals, \$A_INSE)
xx	Sub-module No.	01–02	Index of the system variable word (each 32 bit)
nn	I/O No.	01–20	Bit number in the system variable word \$A_OUTSID[xx], \$A_INSID[xx], \$A_INSED[xx]

6.1 Machine data for SINUMERIK 840D

Additional parameterization for local outputs on the NCU (from SW 6.3.21 onwards):

s = 0

s = 1

nn

36980	\$MA_SAFE_SVSS_STATUS_OUTPUT		
MD number	Output assignment, SBH/SG active		
Standard value: 0	Min. input limit: –	Max. input limit: –	
Change becomes effective after: Power on	Protective stage: 7/2	Units: –	
Data type: DWORD	applies from SW release: 3.4		
Meaning:	Assigns the output to signal the status of the functions safely–reduced speed and safe operating stop. Signal Means: = 0 SG and SBH are not active (only if STOP C, D or E has not been activated by other functions) = 1 SG or SBH is active		
Special cases, errors,...	<ul style="list-style-type: none"> • Input value of 0 means: There is no assignment, the output remains unaffected • Input value of 80 00 00 00 means: There is no assignment, the output remains fixed at 1 • If a single output signal is connected to a terminal, the following applies: If MD bit 31 is set, then the signal is processed inverted (ss = 81). • If several output signals are connected to the same terminal, the following applies: If MD bit 31 is set (ss = 81), then the relevant signal is initially inverted. The (in some cases inverted) output signals are then AND'ed and the result is output at the terminal. 		
Additional references	/FB/, A4, digital and analog NCK I/O		

6.1 Machine data for SINUMERIK 840D

36981	\$MA_SAFE_SS_STATUS_OUTPUT								
MD number	Output assignment for SBH active								
Standard value: 0	Min. input limit: 0	Max. input limit: –							
Change becomes effective after: Power on	Protective stage: 7/2	Units: –							
Data type: DWORD	applies from SW release: 4.2								
Meaning:	<p>This machine data defines the output or the system variable for the "SBH active" signal. Structure: Refer to the coding of the output assignment</p> <table> <tr> <td>Signal</td> <td>Means</td> </tr> <tr> <td>= 0</td> <td>SBH is not active</td> </tr> <tr> <td>= 1</td> <td>SBH is active</td> </tr> </table>			Signal	Means	= 0	SBH is not active	= 1	SBH is active
Signal	Means								
= 0	SBH is not active								
= 1	SBH is active								
Special cases, errors,...	<ul style="list-style-type: none"> If a single output signal is connected to a terminal, the following applies: If MD bit 31 is set, then the signal is processed inverted (ss = 81). If several output signals are connected to the same terminal, the following applies: If MD bit 31 is set (ss = 81), then the relevant signal is initially inverted. The (in some cases inverted) output signals are then AND'ed and the result is output at the terminal. 								

36982	\$MA_SAFE_VELO_STATUS_OUTPUT[n]: 0 ... 1																										
MD number	Output assignment, SG active																										
Standard value: 0	Min. input limit: –	Max. input limit: –																									
Change becomes effective after: Power on	Protective stage: 7/2	Units: –																									
Data type: DWORD	applies from SW release: 4.2																										
Meaning:	<p>This machine data defines the outputs or the system variables for the signals "SG active bit 0" and "SG active bit 1". Structure: Refer to the coding of the output assignment</p> <table> <tr> <td>n = 1, 0</td> <td colspan="2">stands for SG active, bits 1, 0</td> </tr> <tr> <td>SG active</td> <td></td> <td></td> </tr> <tr> <td>Bit 1</td> <td>Bit 0</td> <td>Means</td> </tr> <tr> <td>= 0</td> <td>= 0</td> <td>SG1 active, if SBH/SG is active and SBH is not active</td> </tr> <tr> <td>= 1</td> <td>= 0</td> <td>SBH active, if SBH/SG are active and SBH is active</td> </tr> <tr> <td>= 0</td> <td>= 1</td> <td>SG2 active</td> </tr> <tr> <td>= 1</td> <td>= 1</td> <td>SG3 active</td> </tr> <tr> <td></td> <td></td> <td>SG4 active</td> </tr> </table>			n = 1, 0	stands for SG active, bits 1, 0		SG active			Bit 1	Bit 0	Means	= 0	= 0	SG1 active, if SBH/SG is active and SBH is not active	= 1	= 0	SBH active, if SBH/SG are active and SBH is active	= 0	= 1	SG2 active	= 1	= 1	SG3 active			SG4 active
n = 1, 0	stands for SG active, bits 1, 0																										
SG active																											
Bit 1	Bit 0	Means																									
= 0	= 0	SG1 active, if SBH/SG is active and SBH is not active																									
= 1	= 0	SBH active, if SBH/SG are active and SBH is active																									
= 0	= 1	SG2 active																									
= 1	= 1	SG3 active																									
		SG4 active																									
Special cases, errors,...	<ul style="list-style-type: none"> If a single output signal is connected to a terminal, the following applies: If MD bit 31 is set, then the signal is processed inverted (ss = 81). If several output signals are connected to the same terminal, the following applies: If MD bit 31 is set (ss = 81), then the relevant signal is initially inverted. The (in some cases inverted) output signals are then AND'ed and the result is output at the terminal. 																										

6.1 Machine data for SINUMERIK 840D

36984	\$MA_SAFE_EXT_PULSE_ENAB_OUTPUT		
MD number	Assignment of the output terminal to select "external pulse enable"		
Standard value: 0	Min. input limit: 0	Max. input limit: 0x811E0810	
Change becomes effective after: RESTART		Protective stage: 7/2	Units: –
Data type: DWORD		applies from SW release: 6.3	
Meaning:	<p>This MD must be parameterized as soon as the internal pulse cancellation function is used (bit 30 in \$MA_SAFE_PULSE_ENABLE_OUTPUT=1)</p> <p>Structure: Refer to the coding of the input assignment</p> <p>With each machine data of this kind, a single I/O bit is connected to a terminal or a system variable. Otherwise, the structure of the machine data is the same as for 36970 and onwards.</p>		
Special cases, errors,...			
Additional references			

36985	\$MA_SAFE_VELO_X_STATUS_OUTPUT								
MD number	Output assignment for $n < n_x$								
Standard value: 0	Min. input limit: –	Max. input limit:							
Change becomes effective after: Power on		Protective stage: 7/2	Units:						
Data type: DWORD		applies from SW release: 4.2							
Meaning:	<p>This machine data defines the output or the system variable for the signal "$n < n_x$".</p> <p>Structure: Refer to the coding of the output assignment</p> <table border="0"> <tr> <td>Signal</td> <td>Means</td> </tr> <tr> <td>= 0</td> <td>Actual speed is higher than the limit speed in \$MA_SAFE_VELO_X</td> </tr> <tr> <td>= 1</td> <td>Actual speed is lower or equal to the limit speed</td> </tr> </table>			Signal	Means	= 0	Actual speed is higher than the limit speed in \$MA_SAFE_VELO_X	= 1	Actual speed is lower or equal to the limit speed
Signal	Means								
= 0	Actual speed is higher than the limit speed in \$MA_SAFE_VELO_X								
= 1	Actual speed is lower or equal to the limit speed								
corresponds with...	\$MA_SAFE_VELO_X								
Special cases, errors,...	<ul style="list-style-type: none"> If a single output signal is connected to a terminal, the following applies: If MD bit 31 is set, then the signal is processed inverted (ss = 81). If several output signals are connected to the same terminal, the following applies: If MD bit 31 is set (ss = 81), then the relevant signal is initially inverted. The (in some cases inverted) output signals are then AND'ed and the result is output at the terminal. 								

6.1 Machine data for SINUMERIK 840D

36986	\$MA_SAFE_PULSE_ENABLE_OUTPUT								
MD number	Output assignment, enable pulses								
Standard value: 0	Min. input limit: 0	Max. input limit: –							
Change becomes effective after: Power on	Protective stage: 7/2	Units: –							
Data type: DWORD	applies from SW release: 3.4								
Meaning:	<p>This machine data defines the output for the request "enable pulses". Structure: Refer to the coding of the output assignment</p> <table> <tr> <td>Signal</td> <td>Means</td> </tr> <tr> <td>= 0</td> <td>Request for pulse cancellation</td> </tr> <tr> <td>= 1</td> <td>Request for pulse enable</td> </tr> </table>			Signal	Means	= 0	Request for pulse cancellation	= 1	Request for pulse enable
Signal	Means								
= 0	Request for pulse cancellation								
= 1	Request for pulse enable								
Special cases, errors,...	<ul style="list-style-type: none"> If a single output signal is connected to a terminal, the following applies: If MD bit 31 is set, then the signal is processed inverted (ss = 81). If several output signals are connected to the same terminal, the following applies: If MD bit 31 is set (ss = 81), then the relevant signal is initially inverted. The (in some cases inverted) output signals are then AND'ed and the result is output at the terminal Bit 30 has the following special significance If bit 30 is set to 1, the internal pulse cancellation via the drive bus is used (this is only permissible for 611 digital Performance 2 modules). In this case, the MDs for external pulse enabling must also be appropriately parameterized as an additional safety measure in the event that the internal pulse cancellation fails (\$MA_SAFE_EXT_PULSE_ENABLE_OUTPUT and \$MA_SAFE_STOP_REQUEST_EXT_INPUT) Possible values of i: Value 0: The SGA "enable pulses" is output at the parameterized interface (SPL or I/O). Value 4: The pulses are internally cancelled via the drive bus. The SGA "enable pulses" contains the same information and is output at the parameterized interface (SPL or I/O). If mm, xx and nn=0, then this SGA is not transferred. Value 8: The SGA "enable pulses" is inverted and output at the parameterized interface. Value 12 (=0CH): The pulses are internally cancelled via the drive bus. The SGA "enable pulses" contains the same information and is output inverted at the parameterized interface. 								

6.1 Machine data for SINUMERIK 840D

36987	\$MA_SAFE_REFP_STATUS_OUTPUT		
MD number	Output assignment, axis safely referenced		
Standard value: 0	Min. input limit: 0	Max. input limit: –	
Change becomes effective after: Power on	Protective stage: 7/2	Units: –	
Data type: DWORD	applies from SW release: 3.4		
Meaning:	<p>This machine data specifies the output for the "axis safely referenced" signal. Structure: Refer to the coding of the output assignment Signal = 0 Axis is not safely referenced (i.e. SE is de-activated!) = 1 Axis is safely referenced</p>		
Special cases, errors,...	<ul style="list-style-type: none"> If a single output signal is connected to a terminal, the following applies: If MD bit 31 is set, then the signal is processed inverted (ss = 81). If several output signals are connected to the same terminal, the following applies: If MD bit 31 is set (ss = 81), then the relevant signal is initially inverted. The (in some cases inverted) output signals are then AND'ed and the result is output at the terminal. 		
Additional references	MD 36980: \$MA_SAFE_SVSS_STATUS_OUTPUT		

36988	\$MA_SAFE_CAM_PLUS_OUTPUT[n]: 0 ... 3		
MD number	Output assignment, SN1+ to SN4+		
Standard value: 0	Min. input limit: –	Max. input limit: –	
Change becomes effective after: Power on	Protective stage: 7/2	Units: –	
Data type: DWORD	applies from SW release: 3.4		
Meaning:	<p>This machine data specifies the outputs for the plus cams SN1+ to SN4+. Structure: Refer to the coding of the output assignment n = 0, 1, 2, 3 corresponds to the assignment for plus cams SN1+, SN2+, SN3+, SN4+ Signal = 0 Axis is located to the left of the cam (actual value \leq cam position) = 1 Axis is located to the right of the cam (actual value $>$ cam position) (also refer to Chapter 5.7: Safe software cams, output assignment)</p>		
Special cases, errors,...	<ul style="list-style-type: none"> If a single output signal is connected to a terminal, the following applies: If MD bit 31 is set, then the signal is processed inverted (ss = 81). If several output signals are connected to the same terminal, the following applies: If MD bit 31 is set (ss = 81), then the relevant signal is initially inverted. The (in some cases inverted) output signals are then AND'ed and the result is output at the terminal. 		
Additional references	MD 36980: \$MA_SAFE_SVSS_STATUS_OUTPUT		

6.1 Machine data for SINUMERIK 840D

36989	\$MA_SAFE_CAM_MINUS_OUTPUT[n]		
MD number	Output assignment, SN1– to SN4–		
Standard value: 0	Min. input limit: 0	Max. input limit: –	
Change becomes effective after: Power on	Protective stage: 7/2	Units:	
Data type: DWORD	applies from SW release: 3.4		
Meaning:	<p>This machine data defines the outputs for the minus cams SN1– to SN4–.</p> <p>Structure: Refer to the coding of the output assignments = 0, 1, 2, 3 corresponds to the assignment for minus cams SN1–, SN2–, SN3–, SN4–</p> <p>Signal = 0 Axis is located to the left of the cam (actual value < cam position) = 1 Axis is located to the right of the cam (actual value > cam position) (also refer to Chapter 5.7: Safe software cams, output assignment)</p>		
Special cases, errors,...	<ul style="list-style-type: none"> • If a single output signal is connected to a terminal, the following applies: If MD bit 31 is set, then the signal is processed inverted (ss = 81). • If several output signals are connected to the same terminal, the following applies: If MD bit 31 is set (ss = 81), then the relevant signal is initially inverted. The (in some cases inverted) output signals are then AND'ed and the result is output at the terminal. • If the plus cam is negated and applied to an output with the minus cam and the signals are AND'ed, then this results in a single cam signal for area sensing purposes. 		
Additional references	MD 36980: \$MA_SAFE_SVSS_STATUS_OUTPUT		

36990	\$MA_SAFE_ACT_STOP_OUTPUT[n]: 0...3		
MD number	Output assignment of the active STOP		
Standard value: 0	Min. input limit: –	Max. input limit: –	
Change becomes effective after: Power on	Protective stage: 7/2	Units: –	
Data type: DWORD	applies from SW release: 4.4.18		
Meaning:	<p>Assignment of the output terminals to display the stops that are presently active</p> <p>Structure: Refer to the coding of the output assignment</p> <p>n = 0 "STOP A/B is active" n = 1 "STOP C is active" n = 2 "STOP D is active" n = 3 "STOP E is active"</p>		
Special cases, errors,...	<ul style="list-style-type: none"> • The test stop can be detected using the SGA "enable pulses". • "STOP A/B is active" – this can be used for "leading brake control" because after the time specified in MD36956: \$MA_SAFE_PULSE_DISABLE_DELAY a changeover is made from a STOP B to a STOP A. • "STOP A/B is active", "STOP C is active" and "STOP D is active" can be used for the forced checking procedure of external STOPs. 		
corresponds with...	MD 36980: \$MA_SAFE_SVSS_STATUS_OUTPUT		
Additional references	Refer to Chapter 5.2: "External STOPs"		

6.1 Machine data for SINUMERIK 840D

36992	\$MA_SAFE_CROSSCHECK_CYCLE		
MD number	Displays the axial crosswise comparison clock cycle		
Standard value: 0	Min. input limit: –	Max. input limit: –	
Change becomes effective after: Power on	Protective stage: 7/2	Units: –	
Data type: DOUBLE	applies from SW release: 6.3		
Meaning:	Display data: Indicates the effective axial comparison clock cycle in seconds. This is obtained from INFO_SAFE_CYCLE_TIME and the number of data to be compared crosswise. The displayed axial value depends on the associated drive module.		
Special cases, errors,...			

36993	\$MA_SAFE_CONFIG_CHANGE_DATE[n]; n = 0...4		
MD number	Date/time of the last change SI-NCK-MD		
Standard value: –	Min. input limit: –	Max. input limit: –	
Change becomes effective after: RESTART	Protective stage: 7/2	Units: –	
Data type: STRING	applies from SW release: 5.2		
Meaning:	Display data: Date and time of the last configuration change of safety-related NCK machine data.		
Special cases, errors,...			

36994	\$MA_SAFE_PREV_CONFIG[n]; n = 0...4		
MD number	Data, previous safety configuration		
Standard value: 0	Min. input limit: 0	Max. input limit: 4294967295	
Change becomes effective after: Power on	Protective stage: 7/–	Units: –	
Data type: STRING	applies from SW release: 3.4		
Meaning:	When the safety configuration is changed, the safety-related configuration data is saved in this field.		
Special cases, errors,...			

6.1 Machine data for SINUMERIK 840D

36995	\$MA_SAFE_STANDSTILL_POS		
MD number	Standstill position		
Standard value: 0	Min. input limit: –	Max. input limit: –	
Change becomes effective after: Power on	Protective stage: 0/0	Units: –	
Data type: DWORD	applies from SW release: 3.4		
Meaning:	<p>The position at which the axis has currently stopped is displayed in this MD. To be able to perform a plausibility check on the axis referencing when the control system is powered-up the next time, the current axis position is permanently saved (in a non-volatile fashion) when the following events take place:</p> <ul style="list-style-type: none"> • When safe operating stop (SBH) is selected • Cyclically when SE/SN is active 		
Special cases, errors,...	Any manual changes to the MD are detected the next time that the control is powered-up (plausibility check). A new user agreement is required after referencing.		

36997	\$MA_SAFE_ACKN		
MD number	User agreement		
Standard value: 0	Min. input limit: –	Max. input limit: –	
Change becomes effective after: Power on	Protective stage: 7/2	Units: Hexadecimal	
Data type: DWORD	applies from SW release: 3.4		
Meaning:	<p>The status of the user agreement is displayed in this machine data. The user can confirm or cancel his "user agreement" using an appropriate screen. If it is internally detected in the software that the reference to the machine has been lost, then the "user agreement" is automatically cancelled (e.g. when changing over gear ratios or when referencing, the plausibility check when comparing with the saved standstill position fails).</p>		
Special cases, errors,...	Any manual changes to the MD are detected the next time that the control is powered-up (plausibility check). A new user agreement is required after referencing.		

36998	\$MA_SAFE_ACT_CHECKSUM		
MD number	Actual checksum		
Standard value: 2	Min. input limit: –	Max. input limit: –	
Change becomes effective after: Power on	Protective stage: 7/–	Units: Hexadecimal	
Data type: DWORD	applies from SW release: 3.4		
Meaning:	The actual checksum – calculated after power on or a reset – over the current values of safety-related machine data is entered here.		

6.1 Machine data for SINUMERIK 840D

36999	\$MA_SAFE_DES_CHECKSUM		
MD number	Reference checksum		
Standard value: 0	Min. input limit: –	Max. input limit: –	
Change becomes effective after: Power on	Protective stage: 7/1	Units: Hexadecimal	
Data type: DWORD	applies from SW release: 3.4		
Meaning:	This machine data contains the reference checksum over the actual values of safety-related machine data that was saved during the last machine acceptance test.		

37000	\$MA_FIXED_STOP_MODE		
MD number	Travel to fixed endstop mode		
Standard value: 0	Min. input limit: 0	Max. input limit: 3	
Change becomes effective after: Power on	Protective stage: 7/1	Units: Hexadecimal	
Data type: BYTE	applies from SW release:		
Meaning:	<p>This machine data defines how the "Travel to fixed stop" function can be started.</p> <p>Bit 0: "Travel to fixed stop" cannot be selected.</p> <p>Bit 1: Selection "Travel to fixed stop" can only be started the NC program using the command FXS[0,1]=1.</p> <p>Bit 2: The function is only controlled from the PLC</p> <p>Bit 3: NCK and PLC are peers [same priority] (user ensures synchronization)</p>		

6.2 Machine data for SIMODRIVE 611digital

6.2 Machine data for SIMODRIVE 611digital

6.2.1 Overview of the machine data

Table 6-2 Machine data for SIMODRIVE 611digital

No.	Identifier for 611digital	Equivalent MD for 840D	
	Name	No.	Name
1300	\$MD_SAFE_CYCLE_TIME	10090	\$MA_SAFE_SYSCLOCK_TIME_RATIO
	SI monitoring clock cycle		Factor for the monitoring clock cycle
1301	\$MD_SAFE_FUNCTION_ENABLE	36901	\$MA_SAFE_FUNCTION_ENABLE
	Enable safety functions		Enable safety-related functions
1302	\$MD_SAFE_IS_ROT_AX	36902	\$MA_SAFE_IS_ROT_AX
	Axis-specific bits for safety-related functions		Rotary axis
1305	\$MD_SAFE_MODULO_RANGE	36905	\$MA_SAFE_MODULO_RANGE
	Actual value range for SN for rotary axes		Modulo value, safe cams
1316	\$MD_SAFE_ENC_CONFIG	36916	\$MA_SAFE_ENC_IS_LINEAR
	Motor encoder configuration, safety functions Bit 0: Linear scale Bit 1: Sign change Bit 2: 2-encoder system		Linear scale
1317	\$MD_SAFE_ENC_GRID_POINT_DIST	36917	\$MA_SAFE_ENC_GRID_POINT_DIST
	Grid spacing, linear scale		Grid spacing, linear scale
1318	\$MD_SAFE_ENC_RESOL	36918	\$MA_SAFE_ENC_RESOL
	Encoder pulses per revolution		Encoder pulses per revolution
1320	\$MD_SAFE_ENC_GEAR_PITCH	36920	\$MA_SAFE_ENC_GEAR_PITCH
	Leadscrew pitch		Leadscrew pitch
1321	\$MD_SAFE_ENC_GEAR_DENOM[n]	36921	\$MA_SAFE_ENC_GEAR_DENOM[n]
	Denominator of the gearbox ratio, encoder/load		Denominator, gearbox ratio encoder/load
1322	\$MD_SAFE_ENC_GEAR_NUMERA[n]	36922	\$MA_SAFE_ENC_GEAR_NUMERA[n]
	Numerator, gearbox ratio encoder/load		Numerator, gearbox ratio encoder/load
–		36925	\$MA_SAFE_ENC_POLARITY
–			Direction of rotation reversal actual value
1326	\$MD_SAFE_ENC_FREQ_LIMIT	36926	\$MD_SAFE_ENC_FREQ_LIMIT
	Encoder limit frequency for safety-related operation		Encoder limit frequency for safety-related operation
1330	\$MD_SAFE_STANDSTILL_TOL	36930	\$MA_SAFE_STANDSTILL_TOL
	Standstill tolerance SBH		Standstill tolerance
1331	\$MD_SAFE_VELO_LIMIT[n]	36931	\$MA_SAFE_VELO_LIMIT[n]
	Limit values for SG		Limit value for safely-reduced speed
1332	\$MD_SAFE_VELO_OVR_FACTOR [n]	36932	SAFE_VELO_OVR_FACTOR[n]
	Override factor for SG		SG override values
1334	\$MD_SAFE_POS_LIMIT_PLUS[n]	36934	\$MA_SAFE_POS_LIMIT_PLUS[n]
	Upper limit value for SE		Upper limit value for safe limit position
1335	\$MD_SAFE_POS_LIMIT_MINUS[n]	36935	\$MA_SAFE_POS_LIMIT_MINUS[n]
	Lower limit value for SE		Lower limit value for safe limit position

6.2 Machine data for SIMODRIVE 611digital

Table 6-2 Machine data for SIMODRIVE 611digital

	Name	No.	Name
1336	\$MD_SAFE_CAM_POS_PLUS[n]	36936	\$MA_SAFE_CAM_POS_PLUS[n]
	Plus cams position for SN		Plus cams position for safe cams
1337	\$MD_SAFE_CAM_POS_MINUS[n]	36937	\$MA_SAFE_CAM_POS_MINUS[n]
	Minus cams position for SN		Minus cams position for safe cams
1340	\$MD_SAFE_CAM_TOL	36940	\$MA_SAFE_CAM_TOL
	Tolerance for safe cams		Tolerance for safe cams
1342	\$MD_SAFE_POS_TOL	36942	\$MA_SAFE_POS_TOL
	Actual value tolerance, crosswise data comparison		Tolerance, actual value comparison (crosswise)
1344	\$MD_SAFE_REFP_POS_TOL	36944	\$MA_SAFE_REFP_POS_TOL
	Actual value tolerance safe axis position		Tolerance, actual value comparison (referencing)
1346	\$MD_SAFE_VELO_X	36946	\$MA_SAFE_VELO_X
	Speed limit nx		Speed limit n_x
1348	\$MD_SAFE_STOP_VELO_TOL	36948	\$MA_SAFE_STOP_VELO_TOL
	Tolerance, actual speed for SBR		Speed tolerance for safe braking ramp
1349	\$MD_SAFE_SLIP_VELO_TOL	36949	\$MA_SAFE_SLIP_VELO_TOL
	Tolerance 2–encoder drift/slip		Speed tolerance, slip
1350	\$MD_SAFE_MODE_SWITCH_TIME	36950	\$MA_SAFE_MODE_SWITCH_TIME
	Tolerance time for SGE changeover		Tolerance time for SGE changeover
1351	\$MD_SAFE_VELO_SWITCH_DELAY	36951	\$MA_SAFE_VELO_SWITCH_DELAY
	Delay time, SG changeover		Delay time, speed changeover
1352	\$MD_SAFE_STOP_SWITCH_TIME_C	36952	\$MA_SAFE_STOP_SWITCH_TIME_C
	Transition time from STOP C to SBH		Transition time, STOP C to safe standstill
1353	\$MD_SAFE_STOP_SWITCH_TIME_D	36953	\$MA_SAFE_STOP_SWITCH_TIME_D
	Transition time from STOP D to SBH		Transition time, STOP D to safe standstill
1354	\$MD_SAFE_STOP_SWITCH_TIME_E	36954	\$MA_SAFE_STOP_SWITCH_TIME_E
	Transition time from STOP E to SBH		Transition time, STOP E to safe standstill
1355	\$MD_SAFE_STOP_SWITCH_TIME_F	36955	\$MA_SAFE_STOP_SWITCH_TIME_F
	Transition time from STOP F to SBH		Transition time from STOP F to SBH
1356	\$MD_SAFE_PULSE_DISABLE_DELAY	36956	\$MA_SAFE_PULSE_DISABLE_DELAY
	Delay time, pulse cancellation		Delay time, pulse cancellation
1357	\$MD_SAFE_PULSE_DIS_CHECK_TIME	36957	\$MA_SAFE_PULSE_DIS_CHECK_TIME
	Time to check pulse cancellation		Time to check pulse cancellation
1358	\$MD_SAFE_ACC_TEST_TIMEOUT	36958	\$MA_SAFE_ACCEPTANCE_TST_TIMEOUT
	SI acceptance test timer		Time limit for the acceptance test duration
1360	\$MD_SAFE_STANDSTILL_VELO_TOL	36960	\$MA_SAFE_STANDSTILL_VELO_TOL
	Shutdown speed, pulse cancellation		Shutdown speed, pulse cancellation
1361	\$MD_SAFE_VELO_STOP_MODE	36961	\$MA_SAFE_VELO_STOP_MODE
	Stop response for SG		Stop response, safely–reduced speed
1362	\$MD_SAFE_POS_STOP_MODE	36962	\$MA_SAFE_POS_STOP_MODE
	Stop response for SE		Stop response, safe limit position
1363	\$MD_SAFE_VELO_STOP_REACTION[n]	36963	\$MA_SAFE_VELO_STOP_REACTION[n]
	Stop response, SG–specific		Stop response, SG–specific

6.2 Machine data for SIMODRIVE 611digital

Table 6-2 Machine data for SIMODRIVE 611digital

	Name	No.	Name
1370	\$MD_SAFE_TEST_MODE		Corresponds to BTSS variables for NCK
	SI acceptance test mode		
1371	\$MD_SAFE_TEST_STATE		Corresponds to BTSS variables for NCK
	SI acceptance test status		
1380	\$MD_SAFE_PULSE_DIS_TIME_FAIL		Corresponds to BTSS variables for NCK
	Time up to pulse cancellation		
1390	\$MD_SAFE_FIRMWARE_VERSION		
	Firmware release Safety Integrated		
1391	\$MD_SAFE_DIAG_NC_RESULTLIST1 Diagnostics: NC result list 1		Not available for 840D
1392	\$MD_SAFE_DIAG_611digital_RESULTLIST1 Diagnostics: 611digital result list 1		Not available for 840D
1393	\$MD_SAFE_DIAG_NC_RESULTLIST2 Diagnostics: NC result list 2		Not available for 840D
1394	\$MD_SAFE_DIAG_611digital_RESULTLIST2 Diagnostics: 611digital result list 2		Not available for 840D
1395	\$MD_SAFE_STOP_F_DIAGNOSIS Diagnostics for STOP F		For 840D, integrated into the alarm text
1396	\$MD_SAFE_ACKN_WRITE User agreement		Not available for 840D
1397	\$MD_SAFE_ACKN_READ 611digital internal agreement	36997	\$MA_SAFE_ACKN User agreement
1398	\$MD_SAFE_ACT_CHECKSUM Displays the checksum for SI-MD	36998	\$MA_SAFE_ACT_CHECKSUM Actual checksum
1399	\$MD_SAFE_DES_CHECKSUM Checksum for SI-MD	36999	\$MA_SAFE_DES_CHECKSUM Reference checksum
Note:			
•Drive machine data is copied to the drive after the softkey COPY TO DRIVE has been pressed.			
13xx	Drive machine data marked in this way is not taken into account when copying . The machine manufacturer must manually enter this data.		
•The same description as for the equivalent machine data of the 840D system apply to the machine data copied to the drive.			

Downloading standard motor data

When standard motor data is downloaded, some drive machine data is overwritten. If another type of motor is installed (e.g. after repairs have been carried-out) and the associated motor default data is downloaded, then the encoder data must be changed back to its original value.

6.2.2 Description of machine data

1192	\$MD_FORCE_LIMIT_WEIGHT				611digital
Force due to weight				Relevant: FD	Protective stage: 2/4
Units: %	Standard value: 0.0000	Minimum value: -100.0000	Maximum value: 100.0000	Data type: FLOAT	Becomes effective: Immediately

The force due to the weight or the force due to the weight corresponding to the torque is set in MD 1192. The torque/force limit from the NC acts symmetrically upwards and downwards by this torque/force due to weight. MD 1192 has the same units as the NC machine data (MD 32460) for electronic weight equalization, namely percentage with reference to the standstill (zero speed) torque/force (= $kT \cdot I_0$, for synchronous motors) or rated torque (induction motors). MD 1728 can be used to simplify this setting. MD 1728 displays the actual torque/force setpoint in the same format as MD 1192 and MD 32460. If only the force due to weight is effective, then the matching value can be read and transferred into MD 1192 and MD 32460.

1300	\$MD_SAFETY_CYCLE_TIME				611digital
Monitoring clock cycle				Relevant: FD/MSD	
Units: 31.25 μ s	Standard value: 384 (= 12 ms)	Minimum value: 16	Maximum value: 800	Data type: short integer	Becomes effective: POWER ON

This machine data sets the monitoring clock cycle for safe operation.

Position controller clock cycle \leq SI monitoring clock cycle \leq 25ms

The monitoring clock cycle defines the response time of the monitoring functions. It should be noted that a short monitoring clock cycle time increases the load on the CPU.

1301	\$MD_SAFE_FUNCTION_ENABLE				611digital
Enable safety-related functions				Relevant: FD/MSD	
Units: Hexadecimal	Standard value: 0	Minimum value: 0	Maximum value: FFFB	Data type: binary	Becomes effective: POWER ON

This machine data enables the sub-functions for safe operation on an axis-specific or spindle-specific basis. The bit assignment is as follows:

	Bit 15	Bit 14	Bit 13	Bit 12	Bit 11	Bit 10	Bit 9	Bit 8
High byte	Enable safe cams							
	SN4 -	SN4 +	SN3 -	SN3 +	SN2 -	SN2 +	SN1 -	SN1 +
	Bit 7	Bit 6	Bit 5	Bit 4	Bit 3	Bit 2	Bit 1	Bit 0

6.2 Machine data for SIMODRIVE 611digital

Low byte	Enable			Reserved, these bits must be set to 0			Enable	
	Cam synchronization	External STOPS	Override, safely-reduced speed	Enable external ESR activation	Enable actual value synchronization, 2 encoder system	Reserved for functions with absolute reference	SE	SBH/SG

1302	\$MD_SAFE_IS_ROT_AX					611digital
Axis-specific bits for safety-related functions					Relevant: FD/MSD	
Units: –	Standard value: 0	Minimum value: 0	Maximum value: 00 03	Data type: binary	Becomes effective: POWER ON	

Axis and encoder-specific bits for safety-related functions.

	Bit 15	Bit 14	Bit 13	Bit 12	Bit 11	Bit 10	Bit 9	Bit 8
High byte	Reserved, these bits must be set to 0							
	0	0	0	0	0	0	0	0
	Bit 7	Bit 6	Bit 5	Bit 4	Bit 3	Bit 2	Bit 1	Bit 0
Low byte	Reserved, these bits must be set to 0							
	0	0	0	0	0	0	Inch (imperial) system	Axis type

- Bit 0 1: Rotary axis/spindle
- 0: Linear axis
- Bit 1 1: Imperial system
- 0: Metric system

6.2 Machine data for SIMODRIVE 611digital

1305	\$MD_SAFE_MODULO_RANGE				611digital
Actual value range for SN for rotary axes				Relevant: FD/MSD	Valid from: 840D from SW4.2
Units: mdegrees	Standard value: 0	Minimum value: 0	Maximum value: 737 280 000	Data type: long integer	Becomes effective: POWER ON

Actual value range within which safe cams for rotary axes are calculated. The axis must be a rotary axis

(\$MA_/\$MD_SAFE_IS_ROT_AX = 1).

Value = 0:

Modulo correction after +/- 2048 revolutions (i.e. after 737 280 000 mdegrees)

Value > 0 and a multiple of 360 000 mdegrees:

Modulo correction after this value (e.g. value = 360 000 → the actual value range is between 0 and 359.999 degrees, i.e. a modulo correction is carried-out after every revolution).

Corresponding machine data:

MD 36905: \$MA_SAFE_MODULO_RANGE

MD 36936/1336: \$MA_/\$MD_SAFE_CAM_POS_PLUS[n]

MD 36937/1337: \$MA_/\$MD_SAFE_CAM_POS_MINUS[n]

1316	\$MD_SAFE_ENC_CONFIG				611digital
Motor encoder configuration, safety-related functions				Relevant: FD/MSD	
Units: –	Standard value: 0	Minimum value: 0	Maximum value: 00 07	Data type: binary	Becomes effective: POWER ON

	Bit 15	Bit 14	Bit 13	Bit 12	Bit 11	Bit 10	Bit 9	Bit 8
High byte	Reserved							
	0	0	0	0	0	0	0	0
	Bit 7	Bit 6	Bit 5	Bit 4	Bit 3	Bit 2	Bit 1	Bit 0
Low byte	0	0	0	0	0	2–encoder system	Sign change	Motor encoder (IMS)

Bit 0

1: Linear motor encoder (e.g.: Linear scale for linear motors)

0: Rotary motor encoder

Bit 1

1: Sign change

0: No sign change

Bit 2

1: 2–encoder system (the encoder limit frequency is not monitored)

0: 1–encoder system (the encoder limit frequency is monitored)

6.2 Machine data for SIMODRIVE 611digital

1317	\$MD_SAFE_ENC_GRID_POINT_DIST				611digital
Grid spacing, linear scale				Relevant: FD/MSD	
Units: µm	Standard value: 10	Minimum value: 0.010	Maximum value: 8 000	Data type: float	Becomes effective: POWER ON

Grid spacing of the encoder (this only applies to linear encoders)

1318	\$MD_SAFE_ENC_RESOL				611digital
Encoder pulses per revolution				Relevant: FD/MSD	
Units: –	Standard value: 2 048	Minimum value: 1	Maximum value: 100 000	Data type: –	Becomes effective: POWER ON

Number of pulses per encoder revolution (only applies to rotary encoders)

1320	\$MD_SAFE_ENC_GEAR_PITCH				611digital
Leadscrew pitch				Relevant: FD/MSD	
Units: mm/rev	Standard value: 10	Minimum value: 0.1	Maximum value: 8 388.00	Data type: float	Becomes effective: POWER ON

Gear ratio between the encoder and load (this applies to a linear axis with rotary encoder)

1321	\$MD_SAFE_ENC_GEAR_DENOM[n]				611digital
Denominator, gearbox ratio encoder/load				Relevant: FD/MSD	
Units: –	Standard value: 1	Minimum value: 1	Maximum value: 8 388 607	Data type: long integer	Becomes effective: POWER ON

Denominator of the gearbox ratio between the encoder and load, i.e. the denominator of the fraction number of encoder revolutions/**number of load revolutions**
There are a total of 8 values (n = 0 ... 7), whereby, the actual value is selected using SGEs.

1322	\$MD_SAFE_ENC_GEAR_NUMERA[n]				611digital
Numerator, gearbox ratio encoder/load				Relevant: FD/MSD	
Units: –	Standard value: 1	Minimum value: 1	Maximum value: 8 388 607	Data type: long integer	Becomes effective: POWER ON

Numerator of the gearbox ratio between the encoder and load, i.e. the numerator of the fraction **number of encoder revolutions**/number of load revolutions
There are a total of 8 values (n = 0 ... 7), whereby, the actual value is selected using SGEs.

6.2 Machine data for SIMODRIVE 611digital

1326	\$MD_SAFE_ENC_FREQ_LIMIT				611digital
Encoder limit frequency for safety-related operation				Relevant: FD/MSD	
Units: –	Standard value: 300000	Minimum value: 300000	Maximum value: 420000	Data type: long integer	Becomes effective: POWER ON

Sets the encoder limit frequency due to hardware requirements (encoder cable length, encoder type). This only applies to 611digital Performance 2

1330	\$MD_SAFE_STANDSTILL_TOL				611digital
Standstill tolerance				Relevant: FD/MSD	
Units: 0.001 degrees	Standard value: 1 000	Minimum value: 1	Maximum value: 100 000	Data type: long integer	Becomes effective: POWER ON

Limit value for safe standstill monitoring.

This machine data defines the standstill tolerance window for SBH. The actual value must be within this tolerance value otherwise an alarm is output (tolerance for a safe operating stop exceeded) and the drive is switched into safe standstill.

1331	\$MD_SAFE_VELO_LIMIT[n]				611digital
Limit values for safely-reduced speed				Relevant: FD/MSD	
Units: mm/min or rev/ min	Standard value: 2 000	Minimum value: 0	Maximum value: 1 000 000	Data type: float	Becomes effective: POWER ON

Limit values for SG

n = 0, 1, 2, 3 – stand for the limit values of SG1, 2, 3, 4

If the actual speed is greater than this limit value, then the drive initiates a stop response (this can be parameterized in MD 1361: \$MD_SAFE_VELO_STOP_MODE) and switches into the safe operating stop.

When SBH/SG is active and a 1-encoder system is being used, the speed is monitored corresponding to an encoder limit frequency of 200 kHz (300 kHz, 840D from SW3.6 onwards). When this value is exceeded, the parameterized stop response is initiated.

6.2 Machine data for SIMODRIVE 611digital

1332	\$MD_SAFE_VELO_OVR_FACTOR [n]				611digital
Override factor for SG				Relevant: FD/MSD	
Units: %	Standard value: 100	Minimum value: 1	Maximum value: 100	Data type: short integer	Becomes effective: POWER ON

An override can be selected using SGEs for the limit value of the safely-reduced speeds 2 and 4 – and the associated override value (percentage) can be set using this MD.

n = 0, 1, ... , 15 stands for override 0, 1, ... 15

The function "override, safely-reduced speed" is enabled using MD 36901 (MD 1301): \$MA(\$MD)_SAFE_FUNCTION_ENABLE (refer to Chapter 3, "Override for safely-reduced speed").

1334	\$MD_SAFE_POS_LIMIT_PLUS[n]				611digital
Upper limit value for safe limit position				Relevant: FD/MSD	
Units: 0.001 degrees	Standard value: 100 000 000	Minimum value: -2 147 000 000	Maximum value: 2 147 000 000	Data type: long integer	Becomes effective: POWER ON

Upper (positive) limit value for safely monitoring a limit position

n = 0, 1 stands for safe limit positions 1, 2

When passing the active, upper limit value, the drive initiates an alarm (this can be parameterized using MD 1362: \$MD_SAFE_POS_STOP_MODE) and switches into a safe operating stop.

1335	\$MD_SAFE_POS_LIMIT_MINUS[n]				611digital
Lower limit value for safe limit position				Relevant: FD/MSD	
Units: 0.001 degrees	Standard value: -100 000 000	Minimum value: -2 147 000 000	Maximum value: 2 147 000 000	Data type: long integer	Becomes effective: POWER ON

Lower (negative) limit value for SE.

n = 0, 1 stands for safe limit positions 1, 2

When passing the active, lower limit value, the drive initiates an alarm (this can be parameterized using MD 1362: \$MD_SAFE_POS_STOP_MODE) and switches into a safe operating stop.

6.2 Machine data for SIMODRIVE 611digital

1336	\$MD_SAFE_CAM_POS_PLUS[n]				611digital
Plus cams position for safe cams				Relevant: FD/MSD	
Units: 0.001 degrees	Standard value: 10 000	Minimum value: -2 147 000 000	Maximum value: 2 147 000 000	Data type: long integer	Becomes effective: POWER ON

Switching threshold for positive cams.

n = 0, 1, 2, 3 stands for positive cams SN1 +, SN2 +, SN3 +, SN4 +

If the safe actual position is greater than the machine data, then the safety-related output (SGA) assigned to this cam is set to 1.

1337	\$MD_SAFE_CAM_POS_MINUS[n]				611digital
Minus cams position for safe cams				Relevant: FD/MSD	
Units: 0.001 degrees	Standard value: -10 000	Minimum value: -2 147 000 000	Maximum value: 2 147 000 000	Data type: long integer	Becomes effective: POWER ON

Switching threshold for negative cams.

n = 0, 1, 2, 3 stands for negative cams SN1 -, SN2 -, SN3 -, SN4 -

If the safe actual position is greater than the machine data, then the safety-related output (SGA) assigned to this cam is set to 1.

1340	\$MD_SAFE_CAM_TOL				611digital
Tolerance for safe cams				Relevant: FD/MSD	
Units: 0.001 degrees	Standard value: 100	Minimum value: 1	Maximum value: 10 000	Data type: long integer	Becomes effective: POWER ON

Tolerance threshold for all cams.

As a result of the minimum measuring, computational and runtime deviations, when a cam position is passed, the two monitoring channels (NC and drive) rarely detect this at exactly the same time and at exactly the same position. This machine data provides a tolerance window within which cam results in the two monitoring channels may deviate without resulting in an error.

6.2 Machine data for SIMODRIVE 611digital

1342	\$MD_SAFE_POS_TOL				611digital
Tolerance, actual value comparison (crosswise)				Relevant: FD/MSD	
Units: µm or 0.001 de- grees	Standard value: 100	Minimum value: 1	Maximum value: 10 000 or 360 000	Data type: long integer	Becomes effec- tive: POWER ON

Tolerance threshold for the crosswise data comparison of the position actual value between the NC and drive. This machine data provides a tolerance window within which the position actual values of the NC and drive may deviate from one another.

"Finger protection" (approx. 10 mm) is the primary consideration when setting this tolerance value.

If the difference between the position actual values is greater than the tolerance window, the drive outputs an alarm with a fault code.

1344	\$MD_SAFE_REFP_POS_TOL				611digital
Tolerance, actual value comparison (referencing)				Relevant: FD/MSD	
Units: µm or 0.001 de- grees	Standard value: 10	Minimum value: 0	Maximum value: 1 000 or 36 000	Data type: long integer	Becomes effec- tive: POWER ON

Tolerance threshold to check the actual values after referencing. A second absolute actual position is obtained from the last standstill position – that is saved before the encoder is powered-down – and the distance traversed since power-up. These two actual positions must be within the tolerance window or else referencing requires a user agreement. If this user agreement is not present, then an alarm is output with fault code.

The following factors must be taken into consideration when calculating tolerance values:

Backlash, leadscrew errors, temperature errors, torsion for 2–encoder systems, gearbox tolerance for selector gearboxes, lower resolution for 2–encoder systems, oscillation travel for selector gearboxes

1346	\$MD_SAFE_VELO_X				611digital
Speed limit n_x				Relevant: FD/MSD	
Units: mm/min rev/min	Standard value: 20	Minimum value: 0	Maximum value: 1 000	Data type: float	Becomes effec- tive: POWER ON

This machine data defines the speed limit n_x for the SGA " $n < n_x$ ".

A value of 0 means: $n < n_x$ is not active.

6.2 Machine data for SIMODRIVE 611digital

1348	\$MD_SAFE_STOP_VELO_TOL				611digital
Tolerance, actual speed for SBR				Relevant: FD/MSD	Valid from: SW4.2 for 840D
Units: mm/min, inch/ min, rev/min	Standard value: 300.0	Minimum value: 0.0	Maximum value: 20 000.0	Data type: DOUBLE	Becomes effective: POWER ON

After activating the safe braking ramp, the actual speed plus the speed tolerance specified using this machine data is activated as speed limit.

Recommended setting: Refer to Chapter 2, "Safe braking ramp"

1349	\$MD_SAFE_SLIP_VELO_TOL				611digital
Tolerance 2–encoder drift / slip				Relevant: FD/MSD	
Units: mm/min, inch/ min, rev/min	Standard value: 6.0	Minimum value: 0.0	Maximum value: 1000.0	Data type: DOUBLE	Becomes effective: POWER ON

The tolerance specified in this MD is used as the maximum permissible speed difference between the NC and drive if the function in bit 3 of MD 1301 "enable actual value synchronization" is selected. The tolerance in this MD is then used for the crosswise data comparison instead of the tolerance parameterized in \$MD_SAFE_POS_TOL. If this value is exceeded, STOP F is initiated with the detailed code 3 or 55–57 (actual value comparison or dynamic limit value comparison).

1350	\$MD_SAFE_MODE_SWITCH_TIME				611digital
Tolerance time for SGE changeover				Relevant: FD/MSD	
Units: ms	Standard value: 500	Minimum value: 0	Maximum value: 10 000	Data type: float	Becomes effective: POWER ON

Timer for SGE changes. The timer is started every time new SGEs are accepted. The new monitoring functions are immediately active – however, the crosswise comparison of data that can change over time (i.e. actual values and result lists) must be inhibited for a specific time as the two monitoring channels cannot detect the SGE changes at precisely the same time.

Note

System–dependent minimum tolerance time:
2 x PLC cycle time (maximum cycle) + 1 x IPO clock cycle

In addition, the runtime variations in the external circuitry must be taken into account (e.g. relay switching times).

6.2 Machine data for SIMODRIVE 611digital

1351	\$MD_SAFE_VELO_SWITCH_DELAY				611digital
Delay time, speed changeover				Relevant: FD/MSD	
Units: ms	Standard value: 100	Minimum value: 0	Maximum value: 60 000	Data type: float	Becomes effective: POWER ON

The timer is started at the transition from the safely-reduced speed function to the SBH or at the transition from a higher to a lower velocity monitoring. During this time, the SG limit that was last selected remains active. The parameterized value must be selected as low as possible.

Example:

1. The timer is immediately interrupted if a higher SG limit is selected or one that is precisely the same (as the previously active) SG limit.
2. The timer is immediately interrupted if a changeover is made to "non-safe operation" (= NSB SGE "de-select SBH/SG=1).
3. The timer is re-triggered (restarted) if, while the timer is running, a changeover is made to a lower SG limit than was previously active or to SBH.

1352	\$MD_SAFE_STOP_SWITCH_TIME_C				611digital
Transition time, STOP C to safe operating stop				Relevant: FD/MSD	
Units: ms	Standard value: 100	Minimum value: 0	Maximum value: 10 000	Data type: float	Becomes effective: POWER ON

When the time in this timer expires, a transition is made from STOP C (initiated either by SG or SE) to SBH. The parameterized value must be selected as low as possible.

After the time has expired, the axis/spindle is monitored for a safe operating stop. If the axis/spindle was still not able to be stopped, then either a STOP A or STOP B is initiated.

1353	\$MD_SAFE_STOP_SWITCH_TIME_D				611digital
Transition time, STOP D to safe operating stop				Relevant: FD/MSD	
Units: ms	Standard value: 100	Minimum value: 0	Maximum value: 60 000	Data type: float	Becomes effective: POWER ON

When the time in this timer has expired, a transition is made from STOP D (initiated either by SG or SE) into SBH. The parameterized value must be selected as low as possible.

After the time has expired, the axis/spindle is monitored for a safe operating stop. If the axis/spindle was still not able to be stopped, then either a STOP A or STOP B is initiated.

6.2 Machine data for SIMODRIVE 611digital

1354	\$MD_SAFE_STOP_SWITCH_TIME_E				611digital
Transition time, STOP E to safe operating stop				Relevant: FD/MSD	
Units: ms	Standard value: 100	Minimum value: 0	Maximum value: 60 000	Data type: float	Becomes effective: POWER ON

When the time in this timer has expired, a transition is made from STOP E (initiated either by SG or SE) into SBH. The parameterized value must be selected as low as possible.

After the time has expired, the axis/spindle is monitored for a safe operating stop. If the axis/spindle was still not able to be stopped, then either a STOP A or STOP B is initiated.

1355	\$MD_SAFE_STOP_SWITCH_TIME_F				611digital
Transition time, STOP F to safe operating stop				Relevant: FD/MSD	
Units: ms	Standard value: 100	Minimum value: 0	Maximum value: 60 000	Data type: float	Becomes effective: POWER ON

When the time in this timer expires, a transition is made from STOP F to STOP B. The parameterized value must be selected as low as possible.

1356	\$MD_SAFE_PULSE_DISABLE_DELAY				611digital
Delay time, pulse cancellation				Relevant: FD/MSD	
Units: ms	Standard value: 100	Minimum value: 0	Maximum value: 10 000	Data type: float	Becomes effective: POWER ON

Delay time to cancel the pulses after a STOP B was initiated. The parameterized value must be selected as low as possible.

The pulses are cancelled earlier than defined in this machine data if the condition for the pulse cancellation is present via MD 1360: \$MD_SAFE_STAND-STILL_VELO_TOL.

If the timer in this machine data is set to zero, then an immediate transition is made from STOP B to a STOP A (immediate pulse cancellation).

6.2 Machine data for SIMODRIVE 611digital

1357	\$MD_SAFE_PULSE_DIS_CHECK_TIME				611digital
Time to check pulse cancellation				Relevant: FD/MSD	
Units: ms	Standard value: 100	Minimum value: 0	Maximum value: 10 000	Data type: float	Becomes effective: POWER ON

After the time in this timer has expired, the pulses must have been cancelled if this was requested using the SGE "test stop selection". If the pulses have not been cancelled after the parameterized time, a STOP A response is initiated. If the pulses have been cancelled after the parameterized time, this is indicated to the user by setting the SGA "pulses cancelled". The user can now reset the SGE "stop selection".

If this time is exceeded, a STOP A is initiated.

1358	\$MD_SAFE_ACC_TEST_TIMEOUT				611digital
Acceptance test timer				Relevant: FD/MSD	
Units: ms	Standard value: 100	Minimum value: 5 000	Maximum value: 10 000	Data type: float	Becomes effective: POWER ON

Corresponds to MD \$MA_SAFE_ACCEPTANCE_TST_TIMEOUT for NCK as timer starting value to monitor the active acceptance test mode.

1360	\$MD_SAFE_STANDSTILL_VELO_TOL				611digital
Shutdown speed, pulse cancellation				Relevant: FD/MSD	
Units: mm/min or rev/ min	Standard value: 0.0	Minimum value: 0.0	Maximum value: 1 000.0	Data type: float	Becomes effective: POWER ON

Speed, below which the axis is considered to be at a "standstill" and for a STOP B the pulses are cancelled. If this speed threshold is fallen below when the STOP B response has expired, then the higher priority STOP A response with pulse cancellation is activated.

MD 1356: \$MD_SAFE_PULSE_DISABLE_DELAY must be observed. If the delay time expires before the speed limit is fallen below then the drive pulses are prematurely cancelled.

6.2 Machine data for SIMODRIVE 611digital

1361	\$MD_SAFE_VELO_STOP_MODE				611digital
Stop response, safely-reduced speed				Relevant: FD/MSD	
Units: –	Standard value: 5	Minimum value: 0	Maximum value: 14	Data type: short integer	Becomes effective: POWER ON

Selects the STOP response when the safely-reduced speed monitoring responds

= 0, 1, 2, 3 correspond to STOP A, B, C, D – is initiated when a fault/error occurs

= 5 means that the stop response can be configured for specific SGs in MD 36963/1363

1362	\$MD_SAFE_POS_STOP_MODE				611digital
Stop response, safe limit position				Relevant: FD/MSD	
Units: –	Standard value: 2	Minimum value: 2	Maximum value: 4	Data type: short integer	Becomes effective: POWER ON

When the activated safe limit position 1 or 2 is passed, then the stop response specified in this machine data is initiated.

= 2, 3, 4 corresponds to STOP C, D or E – is initiated when a fault/error occurs

1363	\$MD_SAFE_VELO_STOP_REACTION[n]				611digital
Stop response, SG-specific				Relevant: FD/MSD	
Units: –	Standard value: 2	Minimum value: 0	Maximum value: 3	Data type: BYTE	Becomes effective: POWER ON

The stop response programmed in this machine data is initiated if a selected limit value for safely-reduced speed 1, 2, 3 or 4 is exceeded.

n = 0, 1, 2, 3 stand for SG1, SG2, SG3, SG4

Value = 0, 1, 2, 3, 4 corresponds to STOP A, B, C, D, E

This function is only active when MD 36961 and MD 1361 have the value 5. If a value not equal to 5 is entered, then the parameterized stop response from MD 1361 is valid and 1363 is not evaluated.

6.2 Machine data for SIMODRIVE 611digital

1370	\$MD_SAFE_TEST_MODE				611digital
SI acceptance test mode				Relevant: FD/MSD	
Units: –	Standard value: 0	Minimum value: 0	Maximum value: 0xAC	Data type: short integer	Becomes effective: Immediately

Corresponds to the BTSS variables safeAcceptTestMode for NCK – signals the request for an acceptance test mode.

0: Requests that the acceptance test mode is exited, fault/error acknowledgment

0xAC: Requests that the acceptance test mode is selected

1371	\$MD_SAFE_TEST_STATE				611digital
Acceptance test status				Relevant: FD/MSD	
Units: –	Standard value: 0	Minimum value: 0	Maximum value: 0xAC	Data type: short integer	Becomes effective: Immediately

Corresponds to the BTSS variables safeAcceptTestState for the NCK – signals the state of the drive regarding the acceptance test mode:

0:
Acceptance test mode inactive

0xC:
The acceptance test mode cannot be selected on the drive side because there is at least 1 active SI power on alarm.

0xD:
Incorrect ID received in MD 1370

0xF:
Acceptance test timer has expired

0xAC:
Acceptance test mode is active

1380	\$MD_SAFE_PULSE_DIS_TIME_FAIL				611digital
Time up to pulse cancellation				Relevant: FD/MSD	
Units: ms	Standard value: 0	Minimum value: 0	Maximum value: 800	Data type: float	Becomes effective: Restart

After the drive bus fails, the pulses must have been safely cancelled after this time has expired.

6.2 Machine data for SIMODRIVE 611digital

1390	\$MD_SAFE_FIRMWARE_VERSION				611digital
Firmware release, SINUMERIK Safety Integrated				Relevant: FD/MSD	
Units: –	Standard value: –	Minimum value: –	Maximum value: –	Data type:	Becomes effective: POWER ON

The machine data is assigned at each run-up – irrespective of whether SINUMERIK Safety Integrated® is selected or not.

When a separate version ID for SI is displayed, the certification costs incurred with the German Statutory Industrial Accident Insurance Association (BGIA) are reduced as only software releases that incorporate changes have to be registered.

1391 1392	\$MD_SAFE_DIAG_NC_RESULTLIST1 \$MD_SAFE_DIAG_611digital_RESULTLIST1				611digital
Diagnostics, NC result list 1 Diagnostics, 611digital result list 1				Relevant: FD/MSD	
Units: –	Standard value: 0	Minimum value: 0	Maximum value: FFFF FFFF	Data type: Long integer	Becomes effective: POWER ON

This machine data is used to decode faults/errors in result list 1.

Bit No. Function	Bit 31 –	Bit 30 –	Bit 29 –	Bit 28 –	Bit 27 –	Bit 26 –	Bit 25 –	Bit 24 –
Bit No. Function	Bit 23 –	Bit 22 –	Bit 21 –	Bit 20 –	Bit 19 –	Bit 18 –	Bit 17 –	Bit 16 –
Bit No. Function	Bit 15 –	Bit 14 –	Bit 13 SG4	Bit 12 SG4	Bit 11 SG3	Bit 10 SG3	Bit 9 SG2	Bit 8 SG2
Bit No. Function	Bit 7 SG1	Bit 6 SG1	Bit 5 SE2	Bit 4 SE2	Bit 3 SE1	Bit 2 SE1	Bit 1 SBH	Bit 0 SBH

The bits assigned to SI functions have an identical status when there is no error but have different statuses when there is an error. Two bits (bit n+1 and bit n) are assigned to an SI function. The bit values indicate the following states:

Bit n+1	Bit n	State
0	0	State is not selected (not active).
0	1	Function is selected and does not indicate an error.

6.2 Machine data for SIMODRIVE 611digital

Bit n+1	Bit n	State
1	0	Function is selected and the lower limit value has been fallen below.
1	1	Function is selected and the upper limit value has been exceeded.

For a difference between 1391 and 1392 an error has occurred in the safety-related function that is assigned to this bit.

Example:

MD 1391 = 0000 1556_{hex} = 0000 0000 0000 0000 0001 0101 0101 0110_{binary}

MD 1392 = 0000 1557_{hex} = 0000 0000 0000 0000 0001 0101 0101 0111_{binary}

—> Bit 0 is different —> error in the result comparison of the safe operating stop (SBH). All of the data that is involved with the safe operating stop must be checked in the NCK and drive channel.

1393	\$MD_SAFE_DIAG_NC_RESULTLIST2				611digital	
1394	\$MD_SAFE_DIAG_611digital_RESULTLIST2					
	Diagnostics, NC result list 2 Diagnostics, 611digital result list 2				Relevant: FD/MSD	
Units: —	Standard value: 0	Minimum value: 0	Maximum value: FFFF FFFF	Data type: Long integer	Becomes effective: POWER ON	

This machine data is used to decode faults/errors in result list 2.

Bit No. Function	Bit 31 —	Bit 30 —	Bit 29 —	Bit 28 —	Bit 27 —	Bit 26 —	Bit 25 —	Bit 24 —
Bit No. Function	Bit 23 —	Bit 22 —	Bit 21 Cam module range	Bit 20 Cam module range	Bit 19 n _x lower limit	Bit 18 n _x lower limit	Bit 17 n _x upper limit	Bit 16 n _x upper limit
Bit No. Function	Bit 15 SN4 –	Bit 14 SN4 –	Bit 13 SN4 +	Bit 12 SN4 +	Bit 11 SN3 –	Bit 10 SN3 –	Bit 9 SN3 +	Bit 8 SN3 +
Bit No. Function	Bit 7 SN2 –	Bit 6 SN2 –	Bit 5 SN2 +	Bit 4 SN2 +	Bit 3 SN1–	Bit 2 SN1–	Bit 1 SN1+	Bit 0 SN1+

The bits assigned to SI functions have an identical status when there is no error but have different statuses when there is an error.

For a difference between 1393 and 1394 an error has occurred in the safety-related function that is assigned to this bit.

Example:

MD 1393 = 0000 1547_{Hex} = 0000 0000 0000 0000 0001 0101 0100 0111_{Binary}

MD 1394 = 0000 1557_{hex} = 0000 0000 0000 0000 0001 0101 0101 0111_{binary}

—> Bit 4 is different —> error in the result comparison of the safe cams (SN2 +).

All of the data that involves these cams should be checked in the NCK and drive channel.

6.2 Machine data for SIMODRIVE 611digital

1395	\$MD_SAFE_STOP_F_DIAGNOSIS				611digital
Diagnostics for STOP F				Relevant: FD/MSD	
Units: –	Standard value: 32 767	Minimum value: 0	Maximum value: 32 767	Data type: Integer	Becomes effective: Immediately

The detailed diagnostics for the following alarms is displayed in this machine data:

For 840D Alarm 27001 "Defect in a monitoring channel"

For 611digital Alarm 300911 "Defect in a monitoring channel"

For fault code = 1: Evaluate the detailed fault coding in MDs 1391 and 1392

For fault code = 2: Evaluate the detailed fault coding in MDs 1393 and 1394

For SINUMERIK 840D, the fault code is output together with the alarm display.

Note

Fault code for Stop F is shown in detail in Alarm 27001.

1396	\$MD_SAFE_ACKN_WRITE				611digital
User agreement				Relevant: FD/MSD	
Units: Hexadecimal	Standard value: 00 00	Minimum value: 00 00	Maximum value: FF FF	Data type: binary	Becomes effective: Immediately

The user must manually enter a user agreement so that the axis changes over from the "axis referenced" state (NST) into the "axis safely referenced" state (SGA). The user agreement is no longer necessary for each additional axis referencing if the automatic comparison between the standstill position and the "reference position" at run-up returns a positive result.

Bit 15 ...0	Meaning
= 00AC	Agreement set
= 0	Agreement not set

1397	\$MD_SAFE_ACKN_READ				611digital
611digital, internal agreement				Relevant: FD/MSD	
Units: Hexadecimal	Standard value: 00 00	Minimum value: 00 00	Maximum value: FF FF	Data type: binary	Becomes effective: Immediately

Displays that an axis is in the "axis safely referenced" state after the user agreement has been issued.

6.2 Machine data for SIMODRIVE 611digital

Bit 15 ...0	Meaning
= 00AC	Agreement set
= 0	Agreement not set

1398	\$MD_SAFE_ACT_CHECKSUM				611digital
Display, checksum of the machine data for safety-related functions				Relevant: FD/MSD	
Units:	Standard value: 00 00 00 00	Minimum value: 00 00 00 00	Maximum value: FF FF FF FF	Data type: long integer	Becomes effective: POWER ON

The actual checksum calculated after power on over the actual values of the SI machine data is entered here.

If the actual checksum does not match the reference checksum in MD 1399: \$MD_SAFE_DES_CHECKSUM, then Alarm 300744 "checksum error, safe monitoring" is displayed.

1399	\$MD_SAFE_DES_CHECKSUM				611digital
Checksum over machine data for safety-related functions				Relevant: FD/MSD	
Units:	Standard value: 00 00 00 00	Minimum value: 00 00 00 00	Maximum value: FF FF FF FF	Data type: long integer	Becomes effective: POWER ON

This machine data contains the reference checksum of the actual values of the SI machine data that was saved during the last machine acceptance test.

After power on, the actual checksum is calculated, entered into MD 1398: \$MD_SAFE_ACT_CHECKSUM – and compared with the reference checksum in this data.

If the values are not identical, data has either been changed or there is an error and Alarm 300744 "Checksum error, safe monitoring" is displayed.

6.3 System variables

6.3.1 System variables for SINUMERIK 840D

System variables

Table 6-3 Overview of system variables

System variables	Meaning	Value range	Data type	Possible access for			
				Part programs		Synchronous action	
				r	w	r	w
Actual position							
\$VA_IS[axis]	Safe actual position for Safety Integrated		DOUBLE	x		x	
\$AA_IM[axis]	Actual position of the closed-loop control		DOUBLE	x		x	
\$VA_IM[axis]	Encoder actual value in the machine coordinate system		DOUBLE	x		x	
Internal inputs/outputs							
\$A_INSI[n]	NCK input	n = 1, 2, ... 64 stand for the No. of the input	BOOL	x		x	
\$A_INSID[n]	NCK inputs	n = 1,2	INT	x		x	
\$A_INSIPI[n]	Image, PLC input	n = 1,2, ...64	BOOL	x		x	
\$A_INSIPIPD[n]	Image of the PLC – SPL inputs from the drive monitoring channel	n = 1,2	INT	x		x	
\$A_OUTSI[n]	NCK output	n = 1, 2, ... 64 stand for the No. of the output	BOOL	x	x	x	x
\$A_OUTSID[n]	NCK outputs	n = 1,2	INT	x	x	x	x
\$A_OUTSIPI[n]	Image, PLC output	n = 1, 2, ... 64	BOOL	x		x	
\$A_OUTSIPIPD[n]	Image of the PLC – SPL outputs from the drive monitoring channel	n = 1,2	INT	x		x	
External inputs/outputs							
\$A_INSEI[n]	NCK input	n = 1, 2, ... 64 stands for the No. of the input ¹⁾	BOOL	x		x	
\$A_INSEID[n]	NCK inputs	n = 1,2 ¹⁾	INT	x		x	
\$A_INSEPI[n]	Image of a PLC–SPL input from the PLC HW I/O	n = 1, 2, ... 64 stand for the No. of the input	BOOL	x		x	
\$A_INSEPIPD[n]	Image of the PLC – SPL inputs from PLC HW I/O	n = 1,2	INT	x		x	
\$A_OUTSEI[n]	NCK output	n = 1, 2, ... 64 stands for the No. of the output ¹⁾	BOOL	x	x	x	x
\$A_OUTSEID[n]	NCK outputs	n = 1,2 ¹⁾	INT	x	x	x	x

6.3 System variables

Table 6-3 Overview of system variables

				r	w	r	w
\$A_OUTSEP[n]	Image of a PLC – SPL output from the PLC HW I/O	n = 1, 2, ... 64 stand for the No. of the output	BOOL	x		x	
\$A_OUTSEPD[n]	Image of PLC – SPL outputs from PLC HW I/O	n = 1,2	INT	x		x	
Markers and timers							
\$A_MARKERSI[n]	Bit memories	n = 1, 2, ... 64 stands for the No. of the marker	BOOL	x	x	x	x
\$A_MARKERS-ID[n]	Bit memories	n = 1, 2	INT	x	x	x	x
\$A_MARKERS-IP[n]	Image of the PLC markers	n = 1,2, ...64	BOOL	x		x	
\$A_MARKERS-IPD[n]	Image of the PLC markers	n = 1, 2	INT	x		x	
\$A_TIMERSI[n]	Timer	n = 1, 2...16 stand for the No. of the timer	REAL	x	x	x	x
\$A_STATSID	Crosswise data comparison error triggered if the value is not equal to 0	n = 0 error not initiated n = 1 error initiated	INT	x		x	
\$A_CMDSI	10x change timer timeout value for long forced checking procedure pulses and/or single-channel test stop logic	Bit 0 = 1 10x time active	BOOL	x	x	x	x
\$A_LEVELSID	Crosswise data comparison stack level display: Number of signals for which NCK and PLC detect different signal levels	0...320	INT	x		x	
<p>Note: r -> read, w -> write An implicit preliminary stop is generated Only permitted in the commissioning phase 1) The number of these system variables depends on the option SI Basic or SI Comfort. For SI Basic, the following applies: 4 INSE[1..4] 4 OUTSE[1..4] 4 INSED[1..4] 4 OUTSED[1..4]</p>							

System variable from SW 6

System variables	Meaning	Value range	Data type	Possible access for			
				Part programs		Synchronous action	
				r	w	r	w
Actual position							
\$A_XFAULTSI (from SW 6.4.15)	Bit 0=0: In the crosswise data comparison between NCK and 611D of any axis, an actual-value error has been detected Bit 1=1: In the crosswise data comparison between NCK and 611D of any axis, an error was detected and the delay time until STOP B is initiated for this axis is either running or has already expired.	[0,3]	INT	x		x	
\$VA_XFAULTSI[axis] (from SW 6.4.15)	Bit 0=0: In the crosswise data comparison between NCK and 611D of any axis, an actual-value error has been detected. Bit 1=1: In the crosswise data comparison between NCK and 611D of any axis, an error was detected and the delay time until STOP B is initiated for this axis is either running or has already expired.	[0,3]	INT	x		x	
\$VA_STOPSI[axis] (from SW 6.4.15)	Actual Safety Integrated stop of the relevant axis -1: No stop 0: Stop A 1: Stop B 2: Stop C 3: Stop D 4: Stop E 5: Stop F 10: Test stop 11: Test, external pulse cancellation	[-1,11]	INT	x		x	
\$A_STOPESI (from SW 6.4.15)	Actual Safety Integrated Stop E for any axis 0: No stop otherwise: For one of the axes, a Stop E is present	[0,MAX_INT]	INT	x		x	

6.3 System variables

				r	w	r	w
\$A_PLCSIIN (from SW 6.3.30)	Single-channel direct communication between NCK and PLC-SPL. Signals can be written by the PLC and read by the NCK.	[FALSE, TRUE]	BOOL	x		x	
\$A_PLCSIOUT (from SW 6.3.30)	Single-channel direct communication between NCK and PLC-SPL. Signals can be read by the PLC, written and read by the NCK.	[FALSE, TRUE]	BOOL	x		x	

6.3.2 Description of the system variables

System variable \$VA_IS

The safe actual value, used by SI, can be read and further processed by the NC part program for every axis/spindle.

Example:

When an NC part program is started, Safety Integrated checks whether axis X would move into the vicinity of shutdown limits as a result of the zero offsets when a program is processed. The part program can be programmed as follows, for example:

IF (\$VA_IS[X] < 10000) GOTO POS_OK	;	if the actual value is too high,
MESG ("Axis has nearly reached limit switch!")	;	then the following message,
POS_OK:	;	otherwise, continue here
...		

The variable can also be used in synchronous actions in order to reduce the override when the axis is nearly at the limit switch.

Difference between \$VA_IS and \$AA_IM

Both variable \$VA_IS and variable \$AA_IM can be used to read actual values.

Table 6-4 Difference between \$VA_IS and \$AA_IM

Variable	Meaning
\$VA_IS	Reading the actual value used by SI
\$AA_IM	Reading the actual value used by the closed-loop control (setpoint for the closed-loop position control)

References: /PGA/, Programming Manual, Workshop Planning

System variables \$A_XFAULTSI and \$VA_XFAULTSI

For crosswise data comparison errors between the NCK and 611 digital, the response depends on the actual operating state:

- SBH, SG, SE or SN active: A crosswise data comparison error causes a transition from Stop F to Stop B – which in turn initiates the fastest possible braking of the axis. A Stop A is then initiated and the pulse enable is cancelled.
- SBH and SG are not active and SE/SN is not used or Stop C/D/E has already been activated: In this case, a Stop F due to a crosswise data comparison error does not result in any further action – only Alarm 27001 is output that provides information. Processing then continues.

This chain of responses is not altered to ensure the appropriate level of safety for personnel.

To allow responses to a crosswise data comparison error, system variable \$A_XFAULTSI is used to display that a crosswise data comparison error has occurred on a particular SI axis. Retraction can then be initiated as a response to this system variable.

Further, an axis-specific system variable \$VA_XFAULTSI[<axis name>] has been introduced so that, if necessary, axis-specific responses can be applied.

The system variables are updated independent of whether SI monitoring functions are active or inactive.

\$A_XFAULTSI

Information about Stop F for a safety axis:

- Bit 0 = 1: In a crosswise data comparison between NCK and 611D of any particular safety axis, an actual value error was detected.
- Bit 1 = 1: In the crosswise data comparison between NCK and 611D of any particular axis, a error was detected and the delay time – up until a STOP B is initiated in this axis – is either running or has expired.
(\$MA_SAFE_STOP_SWITCH_TIME_F)

\$VA_XFAULTSI[X] (X = axis identifier)

Information about Safety Integrated Stop F for this axis

6.3 System variables

Bit 0 set:	In the crosswise data comparison between NCK and 611D an actual value error was detected.
Bit 1 set:	In the crosswise data comparison between NCK and 611D – an error was detected and the delay time – up until a STOP B (\$MA_SAFE_STOP_SWITCH_TIME_F) is initiated – is either running or has expired.

System variable \$VA_STOPSI

Axial system variable that contains the present stop. For a value of 2, a Stop E is active for this axis.

System variable \$A_STOPESI

Global system variable that with a value not equal to 0 indicates that a Stop E is active for one particular axis.

System variables \$A_INSI[1...64]

The status signals of the NCK monitoring channel can be used in the NCK–SPL using these system variables. Each of the system variables \$A_INSI[1...64] can be assigned any safety–related output signal or the AND logic operation of several signals using axial MD \$MA_SAFE_XXX_OUTPUT. These system variables can only be read by the user program.

Parameterizing example:

– \$MA_SAFE_CAM_PLUS_OUTPUT[0] = 04010101H
=> the SGA "cam 1+" can be evaluated in the SPL using the system variable \$A_INSI[1].

For a precise description of the MD parameterization, refer to Chapter 4, "Machine data for SINUMERIK 840D".

Programming example:

```
; Copying an SGA from the internal SPL interface into the external
SPL interface (NCK I/O)
```

```
N1010 IDS = 01 DO $A_OUTSE[1] = $A_INSI[1]
```

These system variables can only be read by the user program.

System variables \$A_INSID[1,2]

The status signals of the NCK monitoring channel can be evaluated in the NCK–SPL in a double–word–serial fashion using this system variable:

\$A_INSID[1] corresponds to \$A_INSI[1...32]
\$A_INSID[2] corresponds to \$A_INSI[33...64]

These system variables can only be read by the user program.

System variables \$A_OUTSI[1...64]

The control signals of the NCK monitoring channel can be addressed from the NCK–SPL using these system variables. Each of the system variables \$A_OUTSI[1...64] can be simultaneously assigned any one or several safety–related input signals by using the axial MD \$MA_SAFE_XXX_INPUT.

Parameterizing example:

– \$MA_SAFE_VELO_SELECT_INPUT[0] = 04010204H

=> The SGE "SG selection, bit 0" is controlled in the SPL using the system variable \$A_OUTSI[36].

Programming example:

```
; SGA "cam 1+" (refer above) controls the SG selection
;
N1020 IDS = 02 DO $A_OUTSI[36] = $A_INSI[1]
```

These system variables can be read by the user program and written into by SAFE.SPF.

System variables \$A_OUTSID[1,2]

The control signals of the NCK monitoring channel can be addressed in the NCK–SPL in a double–word–serial fashion using these system variables:

\$A_OUTSID[1] corresponds to \$A_OUTSI[1...32]

\$A_OUTSID[2] corresponds to \$A_OUTSI[33...64]

These system variables can be read by the user program and written into by SAFE.SPF.

System variable \$A_INSE[1...64]

Up to 64 external control signals can be used in the NCK–SPL using these system variables. The state of one byte of an NCK I/O input module can be assigned to a block of eight system variables using MD \$MN_SAFE_IN_HW_ASSIGN[0...7].

```
$MN_SAFE_IN_HW_ASSIGN[0] -> $A_INSE[1...8]
$MN_SAFE_IN_HW_ASSIGN[1] -> $A_INSE[9...16]
$MN_SAFE_IN_HW_ASSIGN[2] -> $A_INSE[17..24]
$MN_SAFE_IN_HW_ASSIGN[3] -> $A_INSE[25..32]
$MN_SAFE_IN_HW_ASSIGN[4] -> $A_INSE[33..40]
$MN_SAFE_IN_HW_ASSIGN[5] -> $A_INSE[41..48]
$MN_SAFE_IN_HW_ASSIGN[6] -> $A_INSE[49..56]
$MN_SAFE_IN_HW_ASSIGN[7] -> $A_INSE[57..64]
```

For a description of the MD parameterization, refer to Chapter 4, "Machine data for SINUMERIK 840D".

These system variables can only be read by the user program.

6.3 System variables

Note

From SW 7 onwards, the number of \$A_INSE is defined by the option SI Basic (4 INSE) or SI_COMFORT (64 INSE).

System variables \$A_INSED[1,2]

The external control signals can be evaluated in the NCK–SPL in a double–word–serial fashion:

\$A_INSED[1] corresponds to \$A_INSE[1...32]

\$A_INSED[2] corresponds to \$A_INSE[33...64]

These system variables can only be read by the user program.

Note

From SW 7, the number of \$A_INSED is defined by the option SI Basic (1 INSED) or SI_COMFORT (2 INSED).

System variables \$A_OUTSE[1...64]

Up to 64 external status signals can be addressed by the NCK–SPL using these system variables. The status of eight system variables can be copied to an NCK I/O output module using MD \$MN_SAFE_OUT_HW_ASSIGN[0...7].

\$MN_SAFE_OUT_HW_ASSIGN[0] <- \$A_OUTSE[1...8]

\$MN_SAFE_OUT_HW_ASSIGN[1] <- \$A_OUTSE[9...16]

\$MN_SAFE_OUT_HW_ASSIGN[2] <- \$A_OUTSE[17..24]

\$MN_SAFE_OUT_HW_ASSIGN[3] <- \$A_OUTSE[25..32]

\$MN_SAFE_OUT_HW_ASSIGN[4] <- \$A_OUTSE[33..40]

\$MN_SAFE_OUT_HW_ASSIGN[5] <- \$A_OUTSE[41..48]

\$MN_SAFE_OUT_HW_ASSIGN[6] <- \$A_OUTSE[49..56]

\$MN_SAFE_OUT_HW_ASSIGN[7] <- \$A_OUTSE[57..64]

For a description of the MD parameterization, refer to Chapter 4, "Machine data for SINUMERIK 840D".

These system variables can be read by the user program and written into by SAFE.SPF.

Note

From SW 7 onwards, the number of \$A_OUTSE is defined by the option SI Basic (4 OUTSE) or SI_COMFORT (64 OUTSE).

System variables \$A_OUTSED[1,2]

The external status signals can be addressed by the NCK–SPL in a double–word–serial fashion using these system variables:

\$A_OUTSED[1] corresponds to \$A_OUTSE[1...32]

\$A_OUTSED[2] corresponds to \$A_OUTSE[33...64]

These system variables can be read by the user program and written into by SAFE.SPF.

Note

From SW 7 onwards, the number of \$A_OUTSE is defined by the option SI Basic (1 OUTSED) or SI_COMFORT (2 OUTSED).

System variables \$A_MARKERSI[1...64]

Up to 64 status bits of the SPL can be flagged using these system variables. The markers are read and written directly into the NCK–SPL.

Programming example:

```
N1030   IDS = 03 DO $A_MARKERSI[2] = $A_OUTSI[1] AND $A_INSE[2]
N1040   IDS = 04 DO $A_OUTSE[1] = $A_MARKERSI[2]
```

System variables \$A_MARKERSID[1,2]

The SPL status bits can be addressed in a word–serial fashion using these system variables.

\$A_MARKERSID[1] corresponds to \$A_MARKERSI[1...32]

\$A_MARKERSID[2] corresponds to \$A_MARKERSI[33...64]

System variables \$A_TIMERSI[1...16]

Up to sixteen timers can be programmed using these system variables.

Programming example:

```
; Set marker once after two seconds, reset the timer value and stop
the timer.
N1050 IDS = 05 WHENEVER $A_TIMERSI[1] > 2.0 DO
      $A_TIMERSI[1] = 0.0 $A_TIMERSI[1] = -1.0
      $A_MARKERSI[2] = 1
```

6.3 System variables

System variable \$A_STATSID

This system variable can be used in the NCK–SPL to evaluate whether, in the crosswise data comparison between NCK and PLC, an error was detected in the two–channel control/processing of the control and status signals. This gives the user the opportunity to respond to this error with specific synchronous actions.

- Bit 0... 27: Crosswise data comparison error in the input/output signals or markers.
- Bit 28: Crosswise data comparison error "SPL protection status" (status \$MN_PREVENT_SYNACT_LOCK not equal to DB18.DBX36.0).
- Bit 29: Time error in the communications between NCK and PLC (in 5 s, all ext. NCK–SPL outputs are set to zero, the PLC goes to stop).
- Bit 30: PLC signals a stop to the NCK.

Programming example:

```
; For a crosswise data comparison error, set ext. output
N1060 IDS = 06 WHENEVER $A_STATSID <> 0 DO $A_OUTSE[1] = 1
```

These system variables can only be read by the user program.

System variable \$A_CMDSI[1]

This system variable can be used to increase the time up to 10 s monitoring the signal changes in the crosswise data comparison between NCK and PLC. This extension (time) is used, among other things, to carry–out the test stop function that must be separately performed for the NCK and drive monitoring channel.

This means that signal differences between the NCK and PLC system variables can be tolerated for up to 10s without Alarm 27090 being output.

This system variable can be read and written into by the user program.

System variable \$A_LEVELSID

This system variable is used to display the stack level of the signal change monitoring in the crosswise data comparison between NCK and PLC. This variable indicates the current number of signals to be checked by the crosswise data comparison function.

Commissioning SPL

Images (mapping) of the PLC–SPL interface and markers are provided to make it easier to commission the SPL. Access to these variables is no longer allowed in the final NCK–SPL program – this means that they are only permitted in the commissioning phase!

System variables \$A_INSIP[1...64]

Images of the PLC-side internal SPL input signals (status signals from the drive monitoring channel) can be read using these system variables.

Associated DB18 values: DB18.DBX54.0 ... DBX61.7

System variables \$A_INSIPD[1,2]

Images of the PLC-side internal SPL input signals (status signals from the drive monitoring channel) can be read in a double-word-serial fashion (32 bit) using these system variables.

Associated DB18 values: DB18.DBD54, DBD58

System variables \$A_OUTSIP[1...64]

Images of the PLC-side internal SPL output signals (control signals to the drive monitoring channel) can be read using these system variables.

Associated DB18 values: DB18.DBX62.0 ... DBX69.7

System variables \$A_OUTSIPD[1,2]

Images of the PLC-side internal SPL output signals (control signals to the drive monitoring channel) can be read in a double-word-serial fashion (32 bit) using these system variables.

Associated DB18 values: DB18.DBD62, DBD66

System variables \$A_INSEP[1...64]

Images of the PLC-side external SPL input signals (control signals to the PLC-SPL) can be read using these system variables.

Associated DB18 values: DB18.DBX38.0 ... DBX45.7

System variables \$A_INSEPD[1,2]

Images of the PLC-side external SPL input signals (control signals to the PLC-SPL) can be read in a double-word-serial fashion (32 bit) using these system variables.

Associated DB18 values: DB18.DBD38, DBD42

System variables \$A_OUTSEP[1...64]

Images of the PLC-side external SPL output signals (status signals from the PLC-SPL) can be read using these system variables.

Associated DB18 values: DB18.DBX46.0 ... DBX53.7

6.3 System variables

System variables \$A_OUTSEPD[1,2]

Images of the PLC-side external SPL output signals (status signals from the PLC-SPL) can be read in a double-word-serial fashion (32 bit) using these system variables.

Associated DB18 values: DB18.DBD46, DBD50

System variables \$A_MARKERSIP[1..64]

Images of the PLC-side SPL markers can be read using these system variables.

Associated DB18 values: DB18.DBX70.0 ... DBX77.7

System variables \$A_MARKERSIPD[1,2]

Images of the PLC-side SPL markers can be read in a double-word-serial fashion (32 bit) using these system variables.

Associated DB18 values: DB18.DBD70, DBD74

System variable \$A_PLCSIIN

Direct single-channel communications between the NCK and PLC-SPL. Signals can be written by the PLC and read by the NCK.

System variable \$A_PLCSIOUT

Direct single-channel communications between the NCK and PLC-SPL. Signals can be read by the PLC and read and written by the NCK.

General information about system variables \$A_xxxP(D)

The system variables are updated in the same clock cycle as the crosswise data comparison between the NCK and the PLC.

These system variables can only be accessed reading.

These system variables may only be used in the commissioning phase.

As soon as commissioning has been signaled as completed, access to these system variables is blocked. If these program commands are processed, Alarm 17210 is output to indicate an error condition.

Note

Write access operations to all of the specified system variables \$A_OUT.../\$A_MARKER... and \$A_TIMERSI are only possible from the program saved in program file /_N_CST_DIR/_N_SAFE_SPF – reserved for the SPL. Access operations from other programs are flagged as an error and Alarm 17070 is output.

6.4 Interface signals

General information

The safety-related input and output signals (SGEs and SGAs) are signals that are sent to and received from the system through two channels:

- Via the NCK monitoring channel status
←→ NCK I/O ←→ signal processing ←→ NCK-SGE/SGA interface ←→
NCK-CPU
- Via the drive monitoring channel status
←→ PLC I/O ←→ signal processing via PLC ←→ **NC/PLC interface**
←→drive CPU

Important

An error in the crosswise data comparison (STOP F, displayed using Alarm 27001, 27101 and onwards or 300911) only results in a subsequent STOP B/A response, if at least one of the safety-related functions SBH, SG, SE or SN is active. If only the function "n < nx" is active, this results in a crosswise comparison error, but not in a subsequent STOP B/A response.

Note

The SGEs/SGAs in the drive monitoring channel are mapped in an area of the NC/PLC interface (signals to/from the drive) and must be supplied in the PLC user program.

As a result of the two-channel structure of Safety Integrated, the machine manufacturer must supply the SGEs and SGAs in both the NCK monitoring channel and the drive monitoring channel.

Unused SGEs must be set to a defined state.

6.4.1 Interface signals for SINUMERIK 840D

Table 6-5 Interface signals for 840D

DB 31...	Signals from/to the drive							
Byte	Bit 7	Bit 6	Bit 5	Bit 4	Bit 3	Bit 2	Bit 1	Bit 0
...	...							
...	...							
...	...							
22	Reserved	Reserved	Reserved	SG selection Bit 1 Bit 0		Reserved	SBH De- selection	SBH/SG De- selection
23	Test stop selection	Reserved	Reserved	SE- selection	Reserved	Gear ratio selection Bit 2 Bit 1 Bit 0		
SGE (signals to the drive)								
32	Reserved	Reserved	De-se- lect ext. STOP_E	De-se- lect ext. STOP_D	De-se- lect ext. STOP_C	De-se- lect ext. STOP_A	Reserved	Reserved
33	SG override selection Bit 3 Bit 2 Bit 1 Bit 0				Reserved	Reserved	Reserved	Reserved
...	...							
...	...							
...	...							
108	Axis safely ref- erenced	Reserved	Reserved	Reserved	Reserved	Status, pulses are can- celled	Reserved	SBH/SG active
109	SN4 -	SN4 +	Cam signals of the plus and minus cams SN3 - SN3 + SN2 - SN2 + SN1- SN1+					
SGA (signals from the drive)								
110	Reserved	Reserved	$n < n_x$	SG active Bit 1 Bit 0		Reserved	SBH active	Reserved
111	STOP_E active	STOP_D active	STOP_C Active	STOP_AB Active	Reserved	Reserved	Reserved	Reserved
Note: DB 31/32/33 ... contain the interface signals for axis/spindle 1/2/3 ...								

6.4.2 Description of the interface signals

Description of the signals sent to the monitoring channel

SGE, SBH/SG de-selection, SBH de-selection

The SBH and SG functions are selected/de-selected using these signals.

Table 6-6 Selecting – de-selecting SBH and SG

SBH/SG de-selection	SGE		Meaning
	SBH de-selection		
= 1	x		SBH and SG are de-selected

6.4 Interface signals

Table 6-6 Selecting – de-selecting SBH and SG, continued

SBH/SG de-selection	SBH de-selection	Meaning
= 0	= 0	SBH is selected (refer to Chapter 5.4: "Safe operating stop (SBH))
= 0	= 1	SG is selected
x: Signal state is optional		

SGE status, pulses cancelled (only for an axis)

This signal provides the NC monitoring channel with feedback as to whether the pulses were cancelled during the test stop.

SGE – SG selection, bits 1, 0

By combining these signals when the SG function is activated it is possible to select the speed limit value for SG1, 2, 3 or 4.

Table 6-7 Selecting the speed limit values for SGn

SGE		Meaning
SG selection bit 1	SG selection bit 0	
= 0	=0	Speed limit value for SG1 is selected
= 0	=1	Speed limit value for SG2 is selected
= 1	=0	Speed limit value for SG3 is selected
=1	=1	Speed limit value for SG4 is selected

SGE gearbox ratio selection, bits 2, 1, 0

The combination of these signals determines the selected gearbox ratio 1, 2, ... ,8.

Table 6-8 Gearbox ratio selection

SGE gearbox ratio selection			Meaning
Bit 2	Bit 1	Bit 0	
0	0	0	Gearbox stage 1 is selected
0	0	1	Gearbox stage 2 is selected
0	1	0	Gearbox stage 3 is selected
...			...
1	1	1	Gearbox stage 8 is selected

SGE SE selection

When this signal is appropriately activated, and the SE function is activated, either SE1 or SE2 is selected.

0 signal: SE1 is selected

1 signal: SE2 is selected

SGE SG override, bits 3, 2, 1, 0

16 overrides for the limit value of safely-reduced speeds 2 and 4 can be defined using the SGEs. This means that the limit values for SG2 and SG4 can be more finely graduated.

An override factor of between 1 and 100% can be assigned to the selected override using the following machine data:

For 840D:

MD 36932: \$MA_SAFE_VELO_OVR_FACTOR[n] (override factor, safely-reduced speed)

For 611digital:

MD 1332: \$MD_SAFE_VELO_OVR_FACTOR [n]

SGE test stop selection

This signal is used to initiate the shutdown path test for the drive monitoring channel (refer to Chapter 3, "Safe response using the shutdown paths and STOPS").

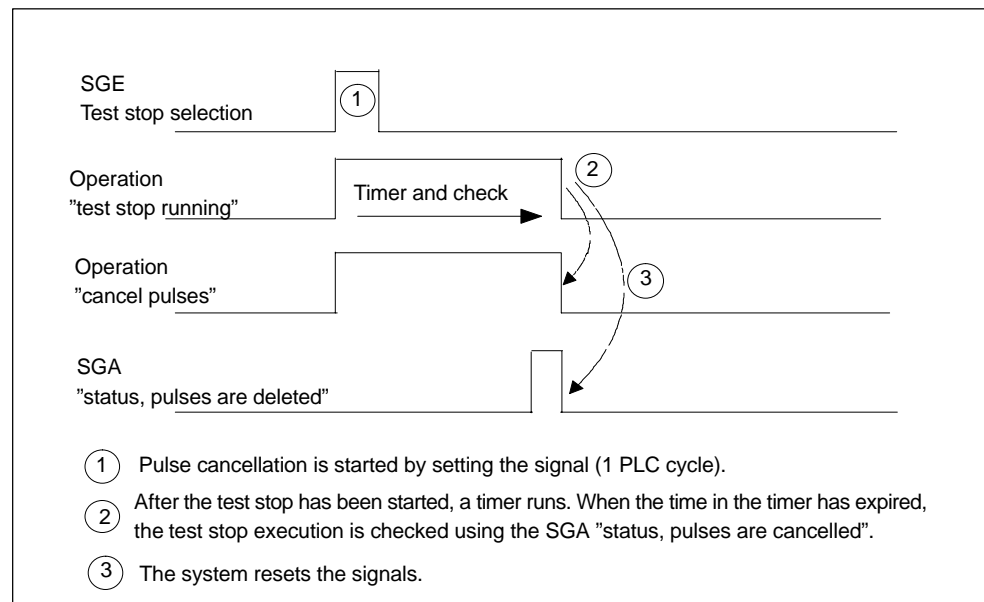

Fig. 6-1 Signal timing for SGE test stop selection

SGE test stop, external shutdown (only at the axis, from SW 6.3.30)

The sequence for "test stop external shutdown" is comparable with the test stop sequence (refer to Chapter 3.1.3, Testing the shutdown paths). After selecting the "test stop external shutdown", the SGA "enable pulse externally" is cancelled and a timer is started with the value from

For 840D MD 36957: \$MA_SAFE_PULSE_DIS_CHECK_TIME

For 611digital MD 1357: \$MD_SAFE_PULSE_DIS_CHECK_TIME

If the timer expires before a feedback signal has been received that the pulses have been cancelled, Alarm 27001 with code number 1010 is output. In addition, a STOP A is initiated for the drive and the pulses are cancelled via the internal shutdown path. This state can only be exited with a power on.

The state of the active monitoring functions (SBH, SG, SE, SN) is not changed by the "test stop external shutdown".

Test stop for external STOPS

This branch must also be subject to a forced-checking procedure due to the fact that an additional possibility has been introduced of activating STOP A, C and D via SGEs.

The test stop of external STOPS is divided into the following 2 phases:

- Phase 1
The shutdown path is tested as usual (refer to Chapter 3, "Testing the shutdown paths"). This tests the correct functioning of the safe pulse cancellation. Successful completion of this phase is signaled as follows:
 - For the NCK monitoring channel:
A positive feedback signal is returned in the form of a 0/1 edge from the SGE "status, pulses cancelled".
 - For the drive monitoring channel:
The positive feedback signal is displayed using the SGA "pulses are cancelled".
- Phase 2
The correct functioning of the safe pulse cancellation was already separately tested for both channels in phase 1. Therefore, in this phase, it is sufficient to check the function of the SGE stop requests.
Procedure:
All of the externally connected/used SGEs for stopping are switched in both channels one after the other and the positive response is evaluated using the associated SGA.

Note

Phase 2 only has to be performed if the function "external STOPS" has been enabled.

Only the enabled and activated external standstill functions have to be tested.

SGE de-select ext. STOP A

"Pulse cancellation" can be requested and executed using this SGE.

The safe functions currently active (SG/SBH/SN/SE) are not influenced by this SGE.

If one of the currently active limits is violated, an appropriate alarm is triggered. The associated shutdown response cannot be activated because the pulses have already been cancelled. As soon as the stop request is cancelled via the SGE "de-select ext. STOP A" any queued shutdown responses become active.

If a stop request is active, SGA "STOP A/B is active" is set in the same way as it would be for an internally triggered STOP A.

0 signal: "Pulse cancellation" is requested

1 signal: "Pulse cancellation" is not requested

SGE de-select ext. STOP C

This SGE requests "braking with $n_{\text{set}} = 0$ " (braking at the current limit).

When this stopping type is initiated, the safe braking ramp (SBR) is activated. In addition, the time set in MD36952/1352:

$\$MA_/\$MD_SAFE_STOP_SWITCH_TIME_C$ (transition time, STOP C to safe operating stop) is started.

After this time has elapsed, the system automatically changes over to SBH.

If a stop request is active, SGA "STOP C is active" is set in the same way as it would be for an internally triggered STOP C.

0 signal: "Braking with $n_{\text{set}} = 0$ " is requested

1 signal: No request for "braking with $n_{\text{set}} = 0$ "

Note

Stopping with an external STOP A (pulse cancellation) has a higher priority and can interrupt an external STOP C (braking at the current limit).

 6.4 Interface signals

SGE de-select ext. STOP D

"Braking along a path" can be requested using this SGE.

When ext. STOP D is triggered, the time set via MD 36953/1353

\$MA_/\$MD_SAFE_STOP_SWITCH_TIME_D (transition time, STOP D to safe operating stop) is started.

After this time has elapsed, the system automatically changes over to SBH.

If a stop request is active, SGA "STOP D is active" is set in the same way as it would be for an internally triggered STOP D.

0 signal: "Braking along a path" is requested

1 signal: "Braking along the path" is not requested

Note

Stopping with an external STOP A (pulse cancellation) and external STOP C (braking at the current limit) have a higher priority and can interrupt an external STOP D (braking along a path).

SGE de-select ext. STOP E (from SW 6.4.15)

This SGE can be used to request a stop via the function "extended stopping and retraction" (ESR). When an external STOP E is initiated, the time stage, set using MD 36954/1354: \$MA_SAFE_STOP_SWITCH_TIME_E/\$MD_SAFE_STOP_SWITCH_TIME_E is started. After this time has elapsed, the system automatically changes over to SBH.

Note

Stopping with an ext. STOP A (pulse cancellation), ext. STOP C (braking at the current limit) and ext. STOP D (braking along a path) have a higher priority and can interrupt an ext. STOP E.

The external STOP E only produces a different response than STOP D if the user has configured the ESR function – extended stop and retract – and initiation of the ESR is programmed depending on \$VA_STOPSI or \$A_STOPESI. If an ESR is not active, then STOP E behaves just like a STOP D. However, if the ESR was incorrectly configured, there is a delay by the time \$MC_ESR_DELAY_TIME1 and \$MC_ESR_DELAY_TIME2 compared to STOP D until the braking operation is initiated.

Description of signals from the monitoring channel

SGA external pulse enable (axis only)

When the pulses are internally cancelled, the pulses are cancelled without using the NCK I/O for the drive module involved (currently only possible for 611D Performance 2 modules). If bit 30 is set in \$MA_SAFE_PULSE_ENABLE_OUTPUT, then the pulses are internally cancelled.

SGA SBH/SG active

This signal is used to signal the drive monitoring channel the status of the SBH and SG functions as follows:

0 signal: SBH/SG is not active
 1 signal: SBH/SG is active

SGA enable pulses (axis only)

This SGA controls terminal 663 to enable signals for the drive.

SGA status, pulses are cancelled (drive only)

After the shutdown path test has been initiated using the SGE test stop selection or if a limit value is violated with a resulting STOP A response, this signal is output to indicate that the drive pulses have been internally cancelled (refer to Chapter 5.1.2, "Shutdown paths").

0 signal: Pulses are enabled
 1 signal: Pulses are cancelled

SGA axis safely referenced

This SGA indicates whether the relevant axis/spindle has been safely referenced (refer to Chapter 4.4.2, "Encoder adjustment, axis calibration").

0 signal: Axis is not safely referenced
 1 signal: Axis is safely referenced

SGA SN1+, SN1-, SN2+, SN2-, SN3+, SN3-, SN4+, SN4-

These signals are used to indicate which of the plus or minus cams of cam pair 1, 2, 3 or 4 is "actuated".

0 signal:
 Axis/spindle is located to the left of the cam (actual value < cam position)
 1 signal:
 Axis/spindle is located to the right of the cam (actual value > cam position)

6.4 Interface signals

SGA SBH active

This signal indicates the status of the safe operating stop (SBH) (refer to Chapter 3, "Safe operating stop (SBH)").

1 signal: SBH is active
0 signal: SBH is not active

SGA STOP A/B is active

This signal indicates that STOP A/B is active.
The signal must be used for the forced checking procedure for external STOPS.

0 signal: STOP A/B is not active
1 signal: STOP A/B is active

SGA STOP C is active

This signal indicates that STOP C is active.
The signal must be used for the forced checking procedure for external STOPS.

0 signal: STOP C is not active
1 signal: STOP C is active

SGA STOP D is active

This signal indicates that STOP D is active.
The signal must be used for the forced checking procedure for external STOPS.

0 signal: STOP D is not active
1 signal: STOP D is active

SGA STOP E is active (840D from SW6.4.15 onwards)

This signal indicates that STOP E is active.
The signal must be used for the forced checking procedure for external STOPS.

0 signal: STOP E is not active
otherwise: STOP E is active

SGA "n < n_x"

This SGA indicates whether the absolute value of the actual speed is above or below a speed specified in the machine data.

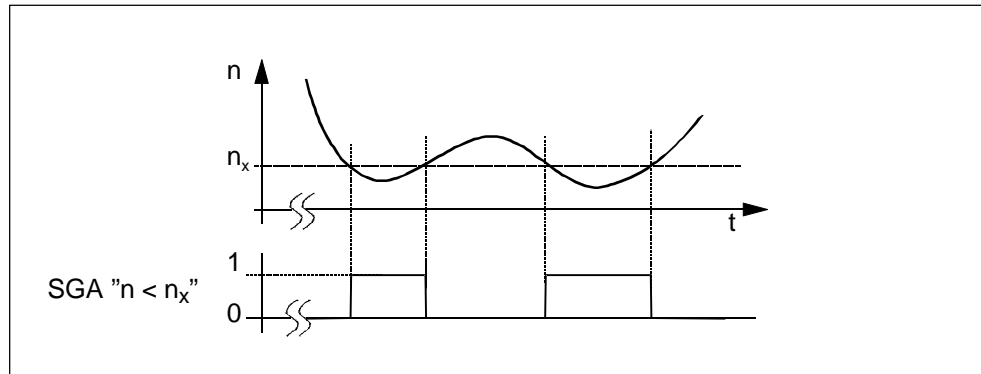

Fig. 6-2 Signal $n < n_x$, dependent on the speed characteristic

Application

Only when the spindle has stopped (SGA "n < n_x" = 0) is the chuck, for example, controlled.

Defining the limit speed n_x

The limit speed n_x is defined using the following machine data:

For 840D MD 36946: \$MA_SAFE_VELO_X

For 611digital MD 1346: \$MD_SAFE_VELO_X

Important

An error in the crosswise data comparison (STOP F, displayed using Alarms 27001, 27101 and onwards or 300911) only results in a subsequent STOP B/A response, if at least one of the safety-related functions SBH, SG, SE or SN is active. If only the function "n < n_x" is active, then a crosswise data comparison error does not result in a subsequent STOP B/A response.

Note

If the axis/spindle runs at a speed n_x , then as a result of actual value differences in the two monitoring channels, the SGA "n < n_x" can have different states. This must be taken into account in the safe processing of the SGAs.

6.4 Interface signals

Description of the SGAs "SG active bits 1, 0"

The SGAs "SG active bits 1, 0" display which safely-reduced speed and therefore which speed limit value is actively monitored. The SGAs are only updated if the function "SBH/SG" is enabled and SG is active (SGE "SBH/SG de-selection" = 0 and "SBH de-selection" = 1).

Table 6-9 Display of the active safely-reduced speed

SG active Bit 1	SGA		SBH active	Meaning
	SG active Bit 0	SBH/ SG active		
=0	=0	1	1	SBH is active (safely-reduced speed is not active)
=0	=0	1	0	Speed limit value for SG1 active
=0	=1	1	0	Speed limit value for SG2 active
=1	=0	1	0	Speed limit value for SG3 active
=1	=1	1	0	Speed limit value for SG4 active
=0	=0	0	0	Neither SBH nor SG is active
Note: Status "SG active, bits 1, 0" = "0" has two different meanings. A clear interpretation can be obtained by additionally evaluating the SGAs "SBH active" and "SBH/SG active".				

Start-up (Commissioning)

7



Warning

After hardware and/or software components have been changed or replaced, it is only permissible to run-up the system and activate the drives when the protective devices are closed. Personnel may not be in the hazardous area.

Depending on the change or replacement, it may be necessary to carry-out a new, partial or complete acceptance test (refer to Chapter 7.2 Acceptance report). Before persons may re-enter the hazardous area, the drives should be tested to ensure that they exhibit stable behavior by briefly moving them in both the plus and minus directions (+/-).

Note

The function "safe software limit switch" (SE) is also called "safe limit positions" and the function "safe software cams" (SN) is also called "safe cams".

Note

If SI functions SH, SBH or SG have been enabled, then they become operational after the control system has run-up (basic display on screen). For the functions "safe limit positions" and "safe cams" safety-relevant position evaluation is only possible after safety-relevant referencing has been successfully completed.



Warning

Protection of operating personnel must be the primary consideration when configuring machine data for SINUMERIK Safety Integrated. This is this reason that the parameterizable tolerances, limit values and delay times should be determined and optimized during the commissioning phase dependent on the machine design and arrangement.

7.1 Commissioning SINUMERIK 840D

7.1.1 Commissioning conditions

Configuring safety-related functions

In order to commission the SI functions, the "Start-up\machine configuration" screen must be selected in the basic control screen using the STARTUP softkey.

For example, the following screen is displayed:

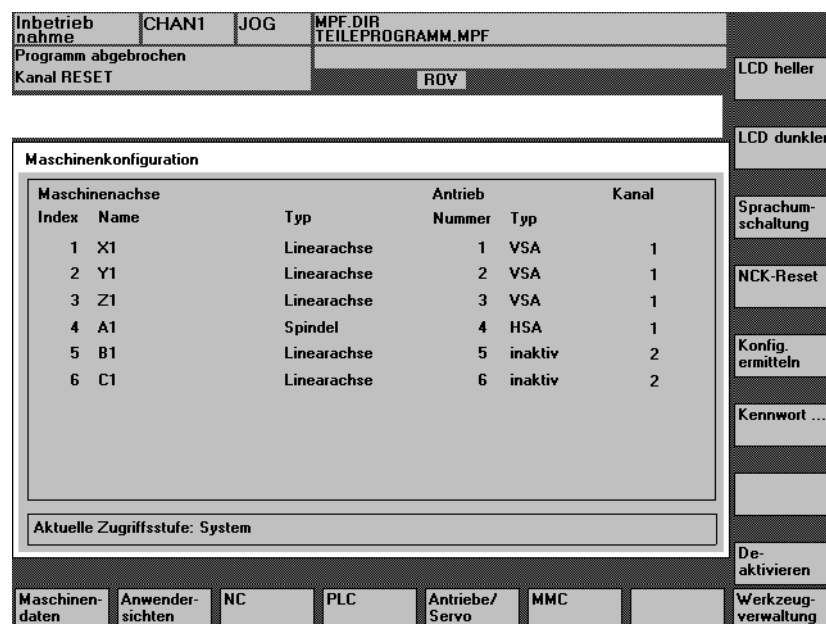

Fig. 7-1 Example of "Start-up\machine configuration" for 840D

The NCK can be reset in this screen.

The softkey "MACHINE DATA" must be selected in order to be able to enter SI data.

To copy and confirm SI data, select the softkey labeled DRIVE CONFIG. to call the appropriate screen. The following screenshot is a typical example:

Inbetriebnahme	CHAN1	JOG	MPF.DIR TEILEPROGRAMM.MPF				
Programm abgebrochen			ROV		Modul einfügen...		
Kanal RESET					Modul löschen		
Antriebskonfiguration							
Steckpl.	Antr.Nr.	Aktiv	Antrieb	Modul	Lstg.Teil	Stromstärke	
1	4	ja <input type="checkbox"/>	HSA	1-Achs	06 H	24/32/32A	Lstg.teil-auswahl...
2	1	ja <input type="checkbox"/>	VSA	2-Achs-1	11 H	3/6A	SI-Daten kopieren
3	2	ja <input type="checkbox"/>	VSA	2-Achs-2	11 H	3/6A	SI-Daten bestätigen
4	3	ja <input type="checkbox"/>	VSA	1-Achs	14 H	9/18A	Speichern
5	5	ja <input type="checkbox"/>	PER	DMP-C			Abbruch
6		<input type="checkbox"/>					Ok
7		<input type="checkbox"/>					
8		<input type="checkbox"/>					
9		<input type="checkbox"/>					
10		<input type="checkbox"/>					
Allgemeine	Kanal-spezifische	Achs-spezifische	Antriebs-Konfigur.	VSA	HSA	Anzeige	Datei-funktionen

Fig. 7-2 Example for "Start-up\drive configuration" for 840D

Softkey COPY SI DATA

When the softkey is pressed, all NC machine data, relevant for the SI functions, is transferred into the corresponding drive machine data.

The SI machine data to define the encoder mounting arrangement must be separately entered for the NCK and drive by the commissioning engineer. The copy function cannot be used to transfer the drive machine data selected in the Table "Machine data for SIMODRIVE".

The boot files are automatically saved after data has been copied.

Softkey CONFIRM SI DATA

After an NCK RESET, the actual checksum is saved by pressing the softkey labeled CONFIRM SI DATA in the "Drive configuration" screen and acknowledging the following dialog box with "OK". From now on, SI data will be monitored for any changes. The boot files are automatically saved after data has been acknowledged.

7.1.2 First commissioning

It is advisable to commission the machine so that at least the axes can be moved. The safety monitoring functions can then be immediately tested after SI data has been entered. This type of test is absolutely essential in order to detect any data entry errors.

The following steps must be taken in the specified sequence to commission SI functions:

Step 1: Enable option

Enable option

- Basic "start-up" screen: Set the password (at least a machine manufacturer password) by selecting softkeys PASSWORD\SET PASSWORD
- "General machine data" screen:
Set the option data for SI.

Step 2: Monitoring clock cycle

Enter the monitoring clock cycle

- "General machine data" screen:
Enter the factor for the monitoring clock cycle in the data \$MN_SAFETY_SYS-CLOCK_TIME_RATIO.
- The actual monitoring time is immediately displayed in data \$MN_INFO_SAFETY_CYCLE_TIME.

Note

Before the next NCK RESET is initiated, you must copy the actual monitoring clock cycle to machine data \$MD_SAFETY_CYCLE_TIME of the drive using softkey COPY SI DATA in the "Drive configuration" screen.

Step 3: Set the axis monitoring

Set the monitoring function for all of the axes to be safely monitored.

Enter the following in the specified sequence in the "axis-specific machine data" screen:

- Function enabling bits
- Axis characteristics (rotary or linear axis)
- Measuring-circuit assignment, i.e. which encoder will supply the "safety" actual value, what type of encoder it is and how it is mechanically mounted.
- For rotary axes, an NCK RESET must now be issued.
- Monitoring limits and tolerances
- Changeover and monitoring times
- Stop responses after a monitoring function has responded
- Assignment of safety-related inputs and outputs, i.e. which hardware terminals are supplying the drive signals for the NC monitoring channel and where are the feedback and cam signals being sent (the PLC handles this link for the drive monitoring channel, i.e. there is no corresponding drive machine data).

Recommendation:

The software limit switches should be set closer together while the system is being commissioned.

Step 4: Actual value and measuring circuit assignment

Assign measuring circuits and actual values to axes/spindles

- Press the softkey labeled COPY SI DATA in the "Drive configuration" screen
- Enter the measuring circuit assignment, i.e. which encoder will supply the safe actual value – the type of encoder being used and how it is mechanically mounted – for each drive in the "FD machine data" or "MSD machine data" screen. For ERN 1387 encoders, this step is not required; for EQN 1325 encoders, only the data for the absolute encoder has to be set. At the same time, the data, copied using the softkey, can be visually checked.
- If you alter anything in the "FD or MSD" screen, press the softkey SAVE BOOT-FILES to transfer the setting to the non-volatile memory.
- Carry-out an NCK-RESET

Step 5: Acknowledge/save monitoring data

Acknowledge/save monitoring data

- Press the CONFIRM SI DATA softkey in the "Drive configuration" screen. A dialog box describing the function of the softkey then appears. After acknowledging with OK, the actual checksum of the safety-related data is then saved in both monitoring channels and monitored for changes from this point onwards. Drive data is also automatically saved to a non-volatile memory (the same as for SAVE BOOTFILES). A dialog box is now displayed on the screen requesting you to perform an acceptance test. You must acknowledge the box.
- The safety monitoring functions are now ready to be used and can be activated as described in Chapter 4.1, "Monitoring clock cycle", Chapter 4.2 and "Cross-wise data comparison".

Step 6: User agreement

Issue a user agreement (refer to Chapter 4.4.3, "User agreement")

- The safe limit positions and safe cams are now activated (provided that they have been enabled, refer to Chapter 4.5, "Enabling safety-related functions"). This step can be omitted if you do not wish to use either of these functions.
- The key-operated switch must be set to position 3 in order to issue a user agreement.

Step 7: Machine commissioning

Carry-out general machine tests.

- Optimize the axes/spindle.
- Adjust SI functions (monitor limits, timers).

Step 8: Acceptance test

Carry-out the acceptance test and enter in the logbook.

- A function test must be carried-out for all of the enabled safe monitoring functions and for each axis/spindle. For suggestions on how to test activated SI functions, please refer to Chapter 7.3, "Acceptance test" and 7.2 "Acceptance report".

Step 9: Re-activate standard monitoring functions

All standard monitoring functions (e.g. zero-speed monitor, software limit switches) that were de-activated or altered for the purpose of the acceptance test must now be re-activated/the original settings restored.

Step 10: Save machine data

Save machine data.

- Use the SERVICES\DATA OUTPUT softkeys to save all machine data to an external computer or the hard disk in the MMC. This data can be used to commission series equipment.
- In order to carry-out series commissioning, the machine data of the NCK and drive must be available as separate data sets (the softkey COPY SI DATA may not be used for the purpose of commissioning series equipment).

**Caution**

After the acceptance test has been completed, all illegal (old) MD files must be removed from the hard disk (to avoid confusion between old and new data). Data that corresponds to the acceptance test data must be backed-up (archived).

Step 11: Delete password

To delete the password, go to the screen "Start-up\Machine configuration" and select the vertical softkey labeled PASSWORD...\DELETE PASSWORD.

7.1.3 Series commissioning

The setting for the safety monitoring functions is automatically transferred with other data in the course of a normal series commissioning process. The following steps need to be taken in addition to the normal commissioning procedure

1. Enter a user agreement
2. Carry-out an acceptance test
(individual monitoring functions must be randomly tested)

Sequence of operations for series commissioning

The following sequence of operations is recommended when commissioning series equipment:

- Download the data set for the series machine into the control.
- Adjust the absolute encoder
- Carry-out a power on
This ensures that any errors – i.e. deviations in the data content that may exist between the NCK and drive – will be detected by the checksum check and crosswise data comparison.
Data must be checked if an error is detected.
If an error is not detected, then data has not been changed and is identical to the acceptance test data. The copy function may be used if data is subsequently altered.
- Carry-out random function tests
The tests are required for acceptance of the new machine.
- Set special features
When special features are set, each altered safety data must be checked.
The copy function may be used.

7.1.4 Upgrading software



Important

Please carefully read the instructions in the relevant Update Manual before updating the software.

7.1.5 Changing data

The user must enter the correct password before he can transfer the machine data for SI functions to the system. After data for SI functions has been altered, a new acceptance test must be carried-out on the SI function(s) involved and then recorded and confirmed in the acceptance report.

Change report

Changes made to NCK machine data important for Safety Integrated are recorded in a display data. The times that these changes were made are displayed in axial MD 36996: \$MA_SAFE_CONFIG_CHANGE_DATE[0...4].

This MD can neither be overwritten by manual entry nor by loading an MD archive. It can only be deleted by running-up the control from the general reset mode (switch position 1).

After the control has been run-up from the general reset mode, nothing is displayed in the MD.

```
36996:    SAFE_CONFIG_CHANGE_DATE[0]    25/08/98 17:35:23
```

This data is updated when the following changes are made to the NCK machine data:

- When a modified safety MD configuration is activated (NCK safety MD have been changed and acknowledged by correction of \$MA_SAFE_DES_CHECKSUM).
- When MD \$MA_SAFE_FUNCTION_ENABLE is changed from values not equal to zero to zero, or from zero to values not equal to zero. These changes mean that the safety functionality of an axis is completely enabled/disabled. Other changes to MD \$MA_SAFE_FUNCTION_ENABLE always change MD \$MA_SAFE_ACT_CHECKSUM, which themselves have to be acknowledged by changes to MD \$MA_SAFE_DES_CHECKSUM.
- When MD \$MA_SAFE_FUNCTION_ENABLE is changed by reducing the safety option. If the scope of axial safety functions is enabled for more axes than are set in the safety option data, the function enable for the excess number of axes is automatically cancelled again when the control runs-up.
- When an MD archive is downloaded that is different to the currently active NCK MD set
- When upgrading (corresponds to downloading an MD archive)
- Series commissioning (corresponds to downloading an MD archive)

Limitations/constraints

Changes to the MD configuration are only noted when the change becomes active, i.e. after altering MD \$MA_SAFE_DES_CHECKSUM and a subsequent power on. This MD is calculated – also for axes that were not released for Safety Integrated.

7.2 Acceptance report

The machine manufacturer must perform an acceptance test of the activated SI functions on the machine. This test must ensure that all of the limit values are violated for the enabled SI functions to ensure that they are operating correctly.

Note

Some of the standard NC monitoring functions, such as zero speed monitoring, software limit switches, etc. must be de-activated (monitoring limits must be made less sensitive) before the acceptance test is carried out.

The function sequences can be acquired and listed using the servo trace function or using the D/A converter output.

Reference /IAD/, Commissioning Manual, SINUMERIK 840D

Note

If the machine data of SI functions is changed, a new acceptance test must be carried-out for the modified SI function and recorded in the acceptance report.

Note

The acceptance is used to check that the safety functions have been correctly parameterized. The measured values are used to check the plausibility of the configured safety functions. The measured values that are determined are typical and are not worst-case values. They represent the behavior of the machine and the instant in time that the measurement is carried-out. These measurements cannot be used to derive maximum values for run-on distances.

Authorized person, acceptance report

All SI functions must be acceptance-tested by an authorized person and the test results recorded in a test report. The report must be signed by the person who carried-out the acceptance tests. The acceptance test report must be kept in the log-book of the particular machine.

After the SPL has been commissioned the access authorization for the NCK-SPL (SAFE.SPF) via the HMI interface must be reduced to the manufacturer or service level and documented in the acceptance report.

An authorized person in the above sense is a person authorized by the machine manufacturer who on account of his or her technical qualifications and knowledge of the safety functions has the necessary skill sets to perform the acceptance test in the correct manner.

Note

- Please observe the information in Chapter 7.1, "Commissioning SINUMERIK 840D".
 - The acceptance report presented below is both an example and recommendation. The specified values apply to the system chosen for this particular example.
 - Template for the acceptance report:
An electronic template for the acceptance report is available:
 - in the toolbox for SINUMERIK 840D
 - on DOCONCD for SINUMERIK 840D
 - on the service CD for SINUMERIK 840D
 - The acceptance report comprises checking the alarm displays and including the alarm reports in the overall acceptance report. In order to obtain reproducible and comparable alarm displays, during the acceptance test, MD 10094: \$MN_SAFE_ALARM_SUPPRESS_LEVEL must be set to 0 in order to avoid suppressing alarm outputs.
-

Necessity of an acceptance test

A full acceptance test (as described in this Chapter) must always be carried-out when the functionality of Safety Integrated is commissioned for the first time on a machine.

Extended safety-related functionality, transferring the commissioned software to additional series machines, modifications to the hardware, software upgrades etc. make it necessary to carry-out the acceptance test – possibly with a reduced test scope. The conditions prescribing the necessity for, or giving suggestions for the required test scope, are provided below.

Overview/definitions for performing the acceptance test

In order to define a partial acceptance test it is first necessary to describe the individual parts of the acceptance test and then define logical groups that represent the components of the acceptance test.

Contents of the full acceptance test

DOCUMENTATION

Documentation of the machine incl. safety functions

1. Machine description (with overview)
2. Details about the control system
3. Configuration diagram
4. Function table
Active monitoring functions depending on the operating mode, the protective doors and other sensors
Ideally, this table should be the objective and result of the configuring work.
5. SI functions per axis
6. Information about the safety equipment

FUNCTION TEST PART 1

General function check incl. checking the wiring/programming

7. Test the shutdown paths
(check the forced checking procedure of the shutdown paths)
8. Test the external stops
9. Test the forced checking procedure of the inputs and outputs
10. Test the crosswise data comparison of the basic Safety Integrated functions and Safety Integrated SPL system variables
11. Test the Emergency Stop and the safety circuits
12. Test the changeover of SI functions

FUNCTION TEST PART 2

Detailed function test incl. checking the values of the individually used SI functions

13. Test the SI function "safely-reduced speed" – SG
(in each case with evaluated measurement diagram and measured values)
14. Test the SI function "safe operating stop" – SBH
(in each case with evaluated measurement diagram and measured values)
15. Test the SI function "safe software limits" – SE
(in each case with evaluated measurement diagram and measured values)
16. Test the SI function "safe cams" – SN
(check using the diagnostics display and assigned SGAs)
17. If necessary, test the SI function "external stops"
in each case with evaluated measurement diagram and measured values

COMPLETION OF THE REPORT

A report of the commissioning status that was checked is generated with the appropriate counter-signatures

18. Check the SI machine data

7.2 Acceptance report

19. Log the checksums (axis MD / SPL)
20. Complete the NCK commissioning
21. Complete the PLC commissioning
22. Verify the data backup
23. Have the report countersigned

APPENDIX

Reports/measurement records for FUNCTION TEST PART 1/2

Alarm logs/servo trace measurements

Effect of the acceptance test for specific measures

Table 7-1 Scope of the acceptance test depending on specific measures

Measure	Documentation	Function test Part 1	Function test Part 2	Report completion
The encoder system has been replaced (refer to Chap. 10.13)	No	No	Check of safe actual values and function of SE/SN (axis-specific)	Supplement, possibly new checksums and counter-signature
Replace NCU hardware (e.g. upgrade of NCU 572 to NCU 573) If the NCU hardware is identical, no measures are necessary	Supplement, hardware data/ configuration	No	Yes if the system clock cycles or dynamic response have been changed	Supplement, possibly new checksums and counter-signature
The control board has been replaced No measure required if an identical control board is used	Supplement, hardware data/ configuration	No	Partial, if the system clock cycles or dynamic response have been changed (axis specific)	Supplement, possibly new checksums and counter-signature
Hardware of SI-relevant peripherals has been replaced (e.g. I/O modules)	No	Yes with note regarding limitation to replaced components	No	No
The software has been upgraded (NCU/drive/PLC)	Supplement, version data	Yes with note about the new function	Yes if system clock cycles or acceleration characteristics (e.g. also jerk) have been changed or testing the new functioning	Supplement, possibly new checksums and counter-signature

Table 7-1 Scope of the acceptance test depending on specific measures

Measure	Documentation	Function test Part 1	Function test Part 2	Report completion
The software has been upgraded (HMI)	Possible supplement, SW version	No	No	No
An individual limit value has been changed (e.g. SG limit)	Supplement, SI functions per axis	No	Partial test of the changed limit value	Supplement, possibly new checksums and counter-signature
Function expanded (e.g. additional actuator, additional SG stage)	Supplement, SI functions per axis or function table	Yes with note if relevant – limited to adapted parts	Partial test of possible additional limit values	Supplement, possibly new checksums and counter-signature
Data transferred to additional machines with series commissioning	Possibly supplement, machine description (check the SW version)	Yes with note	No, for identical data	No No, if identical data (check the checksums)

The acceptance report is included as a Word file in the toolbox supplied and is made up of the following parts:

- System description
- Description of the safety functions
- Test of safety functions

7.3 Conventional acceptance test

Testing the SGAs and SGEs

The crosswise data comparison functions can be tested by removing the connectors from the NCK I/O (NCU terminal block or mixed I/O modules).

Checking the test stop

The NCK and drive test stop can be checked by monitoring the SGE/SGA signals.

SGEs:

Test stop selection (drive, also the interface signal DB<axis>.DBX23.7 status, pulses are cancelled (only axis).

SGAs:

Shutdown path NCK – enable pulses

Shutdown path feedback signal from the drive – pulses are cancelled, also the interface signal DB<axis>.DBX108.2.

Negative test:

Remove the terminal block for AS1/AS2 from the drive and carry-out the NCK test stop. A STOP A stop response must be initiated.

Testing the SBH SI function

Test the SBH function by violating the monitoring limits.

- NC-controlled traversing motion (JOG).
- Provide positive feedback in the position closed-loop control by reversing the polarity of the position actual value using the machine data.
- Start the function generator with speed controller/setpoint input
Reference /IAD/, Commissioning Manual, SINUMERIK 840D

The distance traveled by the axis until it is stopped by the configured stop response can be read from the actual value display. The time required to stop the axis can be determined by recording the actual speed value using D/A converters.

Testing the SG SI function

The following situations must be tested.

- Correct response:
After the active speed limit value is exceeded, the axis must be stopped by the configured stop response within the changeover time to SBH.
- Incorrect response:
After the active speed limit value is exceeded, the axis is **not** stopped to SBH within the changeover time as a result of the configured stop response. This results in a transition from STOP B to STOP A.
- Changeover between the SG limit values (if set). A limit value is selected that is lower than the actual axis speed.
- Changeover between the SG and SBH functions.

Testing the SN SI function

Testing the cams by passing them at various axis speeds.

- Position the cam at the center of the axis. Pass the cam at various axis speeds and in the rapid traverse mode. Calculate the time and distance traveled by the axis until the desired cam signal (NCK-SGA, PLC-SGA) is output.

Testing the SE SI function

Testing the limit positions by passing them at various axis speeds.

- Locate the limit position at the center of the axis. Pass the position at various axis speeds and in the rapid traverse mode. Determine the remaining distance traveled by the axis until it is stopped by the configured stop response. Locate the safe limit in front of the fixed endstop of the axis at a distance corresponding to the determined remaining distance plus a safety margin defined by the machine manufacturer.

7.4 NCK acceptance test support

General information

The requirements associated with an acceptance test can be derived from the EU Machinery Directive. Presently IEC 22G WG 10 is working on a standard for "functional safety". This also includes a specific description of the requirements for an acceptance test. Accordingly, the machinery construction (OEM) is responsible for the following:

- to carry-out an acceptance test for safety-related functions and machine parts, and
- to issue an "Acceptance certificate" that includes the results of the test.

When using the Safety Integrated function, the acceptance test is used to check the functionality of the SI monitoring functions used in the NCK, PLC and drive. In this case, the correct implementation of the defined safety functions is investigated, the implemented test mechanisms checked (forced checking procedure measures) as well as the response of individual monitoring functions, provoked by individually violating the tolerance limit. This should be carried-out for the safety functions that were implemented using SPL as well as all of the axial monitoring functions of the axes that are monitored with SI.

Previously, the result of the test was a document that was manually created (refer to Chapter 7.2 "Acceptance report"). The test steps required were accompanied, in some instances, by changes made to the PLC program and to MD settings and the alarms that were issued were documented. Further, servo trace plots were evaluated using the associated measuring function and the results and graphics transferred into a document that the OEM had created. The principle contents and structure of such a document was described in Chapter 5.2 "Acceptance report".

Based on this method, the existing SI functionality was expanded in the NCK and drive software in order, in conjunction with an operator interface (SinuCom NC), to support and simplify the test procedure as well as the associated documentation.

The objective of this support is to control the creation and administration of an acceptance report and prepare and carry-out the required test steps using the appropriate operator actions via the operator interface. The test steps that are required as part of the acceptance test are not completely automatically executed but are controlled by a skilled operator. This operator must carry-out the measures, associated with the test step, at the system being tested.

The following mechanisms are applied in order to carry-out the test steps and to optimize the creation of the acceptance report:

- Support when documenting the active monitoring functions and monitoring limit values by reading-out the appropriate machine data.

- Support when documenting the checksum values.
- Standardization of the procedure when carrying-out the test, following a pre-defined test list.
- The time and resources required for testing are reduced by preparing test procedures within the system, automatic trace and evaluation techniques and it takes less time to acknowledge SI alarms that are output.

Software prerequisites

The acceptance test report function is based on the interaction between the NCK/drive and the SinuCom NC operator interface. This means that if this function is used, these components must have a certain minimum software version.

SinuCom NC software	Version 06.03.07. or higher
NCU system software	Version 06.04.15 or higher

The basic functionality of the SinuCom NC software is explained within the scope of its own documentation. This documentation also provides information about the steps when handling the acceptance test support function, a description of the screen forms and the menu prompting. This is the reason that this is not handled in this documentation.

Reference: Start-up Tool SINUMERIK SinuCom NC (INC)

7.4.1 Scope of the test list

The test steps of the SI acceptance test, supported by the system, is based on the previous test execution and comprises the following steps:

Designation	Purpose of the test step
<i>General information</i>	
Overview	Document the machine details (e.g. manufacturer, machine type,...)
<i>Check the forced checking procedure measures</i>	
Shutdown paths	Test the forced checking procedure of the shutdown paths for the NCK and drive.
External stops	Test the forced checking procedure of the (that are being used) external stop responses (when using SPL).
SPL inputs/outputs	Test the forced checking procedure (if required) of the external SPL I/O.
<i>Qualitative function checks</i>	
Emergency Stop	Test the internal Emergency Stop functionality when executed via external stop responses and the response to the external SPL I/O.

7.4 NCK acceptance test support

Designation	Purpose of the test step
Function inter-relationships	Test all of the states relevant for the safety functions that should be first documented within the scope of a function table or similar (interdependency of sensor signals, positions, modes). In this case, the following should be taken into account – the active monitoring function for SI-monitored axes (internal safety functions) and the switching state of safety-related external SPL output peripherals.
<i>Quantitative function checks</i>	
SBH (safe operating stop)	Test the response when provoking that the SBH limit values are violated and define associated characteristic quantities/parameters.
SG (safely-reduced speed)	Test the response when provoking that the SG limit values are violated and define associated characteristic quantities/parameters.
SE (safe software limit switches)	Test the response when provoking that the SE limit value is violated and define associated characteristic quantities/parameters.
<i>Termination</i>	
Completed	The test results are saved and downloaded. The acceptance report is generated based on the test results that have been determined.

7.4.2 Internal mechanisms to support the test procedure

In order to support the execution of the individual test steps, defined states are activated as a result of the interaction between the SinuCom NC operator interface and NCK/drive. This creates the appropriate requirements relating to the limitations and constraints of the test step, that up until now, had to be manually set.

Acceptance test phase

If the acceptance test function is selected on the SinuCom NC operator interface, then on the NCK side, the acceptance test phase is selected. As a result, the acceptance test phase is continually active while working through the test list.

In order to ensure that all of the SI alarms are output when they occur while executing the test steps and that these SI alarms can also be logged, then the alarm suppression that might have been set in MD 10094 \$MN_SAFE_ALARM_SUPPRESS_LEVEL is not taken into account and therefore does not have to be manually reset to 0 for the duration of the acceptance test.

The acceptance test phase is de-selected by exiting the acceptance test function.

Acceptance test mode

For the new acceptance test support provided by the NCK and drive, the SI functions to be tested are sub-divided into groups that require a specific acceptance test mode (acceptance test from group 1, e.g. SBH test, SG test) and in groups that do not require an acceptance test mode (acceptance tests from group 2, e.g. acceptance test for SE).

Acceptance tests with the acceptance test mode

For the test steps of group 1 – these include SBH response and SG response – an additional state is active under defined limitations/constraints. This state has specific internal features that support the test procedure.

This acceptance test mode becomes active under the following limitations/constraints (in a test associated with group 1):

- There is no active SI power on alarm for the axis to be tested.
- The pulses of the axis to be tested are enabled.
- JOG is active as NC operating mode.
- The SI monitoring function selected when carrying-out the test step is active, i.e. if for example the SG2 test is selected as test, then if SG1 is active, the acceptance test mode (group 1) is not active.
- Both monitoring channels (NCK, drive) allow the mode to be activated. The state that is assumed is subject to a crosswise data comparison between the NCK and drive.

For the active acceptance test mode (group 1) the following features are active for the axis to be tested:

- NCK (Alarm No. 27007) and drive (Alarm No. 300952) return the state using the "Acceptance test mode active" alarm.
- The reference (setpoint) speed limit is de-activated using the axial MD 36933 \$MA_SAFE_DES_VELO_LIMIT. This means that machine data is internally handled as if it had been parameterized with 0% This allows the axis to be traversed in spite of the fact that the SBH monitoring is active or a traversing speed greater than the actual SG monitoring without having to change the selected reference (setpoint) speed limiting.
- SI power on alarms can be temporarily acknowledged with a reset so that after an SBH response has been tested for an axis, an NCK reset does not have to be initiated for the fault acknowledgment. This involves the acknowledgment criteria for the following alarms:

7.4 NCK acceptance test support

Alarm No. NCK	Alarm No. drive	Alarm text
27010	300907	Tolerance for safe operating stop exceeded
27023	300901	STOP B initiated
27024	300900	STOP A initiated

- Traversing motion is possible in spite of the external Stop C/D. This means that it is also possible to test the active SBH monitoring state that results from an external Stop.
- An active stop in another axis does not result in a traversing inhibit for the axis being tested – also for the setting MD 36964 \$MA_SAFE_IPO_STOP_GROUP = 0 for this axis.
- When traversing the axes using the JOG buttons, then the set speed limits are ignored – such as e.g. MD 32020 \$MA_JOG_VELO – and the G0 value is activated as effective limit value (maximum axis speed).

This state is only active from time to time as the described acceptance test mode has some extensive internal consequences. It is de-selected using the following conditions:

- As a result of an NCK Reset
- When an internal timer value expires, that defines the maximum time that the state can be active.
This timer value is set in the following machine data
MD 36958 \$MA_SAFE_ACCEPTANCE_TST_TIMEOUT (NCK) and
MD 1358 \$MD_SAFE_ACC_TEST_TIMEOUT (drive).
- Automatically when the measured value has been recorded.
- If the monitoring function to be tested, that was active when selected, is no longer active; e.g. when changing-over from SBH to SG monitoring with the mode active.
- If the acceptance mode is active, but the NC JOG mode is no longer active.

Acceptance tests without acceptance test mode

For the test steps of group 2 – this also involves testing the SE response – under defined limitations/constraints, an additional state is active that has specific internal features to support the test procedure.

This acceptance test (group 2) becomes active under the following limitations/constraints (when group 2 is being tested):

- There is no active SI power on alarm for the axis to be tested.
- The pulses of the axis to be tested are enabled.
- JOG is active as NC operating mode.
- The SI monitoring function selected for the particular test step is active, this means, for example, that if the SE1 test is selected as test, if SE2 is active, the acceptance test mode (group 2) is not active.
- The NCK monitoring channel allows the mode to be activated through one channel.

The following features apply for an active acceptance test (group 2) for the axis to be tested:

- The NCK returns the state (Alarm No. 27008) via the alarm "single-channel software limit switch de-activated".
- The single-channel software limit switches (set positions, refer to MD 36100 to MD 36130) are de-activated. This means that an axis can pass these software limit switches without having to change the associated machine data.

The acceptance test (group 2) is again de-activated for the following conditions:

- As a result of an NCK Reset
- When an internal timer value expires, that defines the maximum time that the state can be active.
This timer value is set in the following machine data
MD 36958 \$MA_SAFE_ACCEPTANCE_TST_TIMEOUT (NCK) and
MD 1358 \$MD_SAFE_ACC_TEST_TIMEOUT (drive).
- Automatically when the measured value has been recorded.
- If the monitoring function to be tested, that was active when selected, is no longer active; e.g. when changing-over from SE1 to SE2 monitoring with the mode active.
- If the acceptance mode is active, but the NC JOG mode is no longer active.

7.4.3 Trace techniques

A test is carried-out prompted step-by-step using the SinuCom NC operator interface. There are various trace techniques, which can be used to confirm and log as to whether the test was successfully completed.

TEXT

Text entry by the operator

A table or cell for the user documentation is provided for the test. This should then be completed corresponding to the specifications. In addition to how the test is initiated, the text entry includes, e.g. a description of test situations and responses or similar.

ALARM

Alarms that occur are automatically logged

Specific system and user alarms expected for the test step that are automatically logged after the data trace function has been started. After the appropriate data has been traced, the selection of alarms to be logged can be reduced to those alarms that are relevant for the specific test step.

TRC

Internal signal trace function

The SinuCom NC internal trace function is started when the data trace is started and the signals, relevant for the specific test step, recorded. After the appropriate trace time (the relevant signal changes have taken place), then the trace must be manually terminated.

TRC+

Internal signal trace function with additional automatic determination of the characteristic quantities

The SinuCom NC internal trace function is started when the data trace is started and the signals, relevant for the specific test step, are recorded. The trace is automatically terminated after the appropriate (expected) signal changes and transitions. The appropriate characteristic quantities for the test are automatically determined and displayed. It is not necessary to manually terminate the trace.

Description of the test step	Text	Alarm	TRC	TRC+
<i>General information</i>				
Overview	X			
<i>Check the forced checking procedure measures</i>				
Shutdown paths	X	X		

Description of the test step	Text	Alarm	TRC	TRC+
External stops	X		X	
SPL inputs/outputs	X	X		
<i>Qualitative function checks</i>				
Emergency Stop	X		X	
Function inter-relationships	X			
<i>Quantitative inter-relationships</i>				
SBH (safe operating stop)	X	X		X
SG (safely-reduced speed)	X	X		X
SE (safe software limit switches)	X	X		X
<i>Termination</i>				
Completed				

Using the internal trace function

Specific NC machine data must be set in order that the trace function can be used. This prepares the appropriate resources for the function. The values to be set should be taken from the SINUMERIK SinuCom NC start-up tool.

7.4.4 Basic operating information and instructions

- The operator is prompted, step-by-step when carrying-out a test. The following limitations/constraints must be observed, especially for those tests that use the internal trace function:

If a traversing direction has been selected, then this must also be taken into account for the subsequent task. The reason for this is that the trigger condition for the automatic data acquisition and evaluation is based on this direction data

A procedure is initiated to activate the trace function using the button <start data acquisition>. This can take several seconds. The signal is only acquired after the appropriate feedback has been received in a message box.

If the trace has to be manually terminated, then this step should, if at all possible, be made directly after the last expected signal change that is relevant for the trace. This ensures that the relevant area is optimally displayed in the subsequent trace display.

- For each test step, the operator must decide as to whether the test was successfully carried-out. He should make this decision based on traced and determined data and test situations that have been carried-out and documented. This can be confirmed after the test has been carried-out by selecting the appropriate results.

7.4 NCK acceptance test support

- The test list, provided and supported by SinuCom NC includes the basic test steps to be carried-out. Depending on the machine configuration, several tests may not be necessary for the particular machine. This can be selected in the basic screen of the test step. Further, there are test cases, that are required for the machine but are not (or still not) included within the scope of the test list, e.g. measuring the braking travel when a light barrier is obstructed, or similar. These tests should still be manually carried-out.
- When generating the acceptance certificate, for documentation purposes, data is automatically retrieved from some machine data (SI limit values, checksums, hardware information).
Further, the results of the tests that were carried-out are incorporated in the document. The report is structured the same as the document that was previously manually created. Some sections, such as for example, the machine overview, function table of the configured safety functions etc., that are not standardized, are still manually incorporated in the document at a later date.

Note

The function "safe software limit switch" (SE) is also called "safe limit positions" and the function "safe software cams" (SN) is also called "safe cams".

8.1 Troubleshooting procedure

- The alarms that have been activated in response to an error are output in the "DIAGNOSIS – ALARMS" display.
- When the alarm "Defect in a monitoring channel" is output, for the NCK monitoring channel, the cause of the alarm can be directly read-out from the diagnostics for STOP F.
- The cause of the alarm in the drive monitoring channel can be found in MD 1395: MD_SAFE_STOP_F_DIAGNOSIS in the START-UP – MACHINE DATA – FDD OR MSD" display.

Note

Different error codes may be displayed for the NCK and drive monitoring channels.

8.1 Troubleshooting procedure

8.1.1 Service displays

- When the "Service SI" softkey is actuated, three data blocks about Safety Integrated related data for the selected axis are listed in HMI Advanced (from SW 6.2):
 - Status SI (selected per default)
 - SGE/SGA
 - SPL

Diagnose	CHAN1	JOG	MPFO	
Kanal unterbrochen			Halt: kein BAG - Ready	Achse +
Programm abgebrochen		ROV	FST	Achse -
27000 ↓ : Achse X1 ist nicht sicher referenziert				Direkt-anwahl...
Status SI				Status SI
AX1:X1 (DR11:SRM)				SGE/SGA
Signal	NCK	Antrieb	Einheit	SPL
Sichere Istposition	0.0000	0.0000	inch	
Lagedifferenz NCK/Antrieb	0.0000	-	inch	
Überwachung "Sicherer Betriebshalt" aktiv	Ja	Nein		
Überwachung "Sichere Geschwindigkeit" aktiv	Nein	Nein		
Aktive SG-Stufe	Keine	Keine		
Aktiver SG-Korrekturfaktor	Keiner	-	%	
Sichere Istgeschwindigkeitsgrenze	Inaktiv	-	inch/min	
Sollgeschwindigkeitsbegrenzung	Inaktiv	-	inch/min	
Aktuelle Geschwindigkeitsdifferenz	0.0000	-	inch/min	
Maximale Geschwindigkeitsdifferenz	0.0000	-	inch/min	
Aktive sichere Software-Endschalter	Keine	Keine		
Aktives Übersetzungsverhältnis (Stufe)	1	1		
Aktiver Stopp	A/B	Keiner		
Aktuell angeforderter externer Stopp	A	A		
Stop-F-Codewert (Alarm 300911)	-	0		

Fig. 8-1 Status SI

The "Axis +", "Axis –" vertical softkeys or direct selection are used to set the desired axis. The active axis is displayed in the top right half of the table.

Available values/signals

- Safe actual position
- Position deviation NCK/drive
- "Safe operating stop" monitoring active
- "Safely-reduced speed" monitoring active
- Active SG step
- Active SG correction factor
- Safe actual speed limit
- Setpoint speed limit
- Actual speed difference
- Maximum speed difference
- Active safe software limit switch
- Active gear ratio (step)

Active stop
 Currently requested external stop
 Pulses enabled
 Stop F code value (Alarm 300911)
 Traversing inhibit due to a stop in other axis

The vertical softkeys "SGE/SGA" and "SPL" can be used to select two additional screens, which show the situation for the safety-related inputs/outputs and the safe programmable logic.

Diagnose	CHAN1	JOG	MPFD	
Kanal unterbrochen		Halt: kein BAG - Ready		Achse +
Programm abgebrochen		ROV	FST	Achse -
27000 ↓ : Achse X1 ist nicht sicher referenziert				
SGE/SGA X1				1
AX1.X1 (DR11:SRM)				Direkt-anwahl...
SGE				
Sichere Eingangssignale NCK Bit 0...15		0000 0000 0000 0000		
Sichere Eingangssignale Antrieb Bit 0...15		0000 0000 0000 0000		
Sichere Eingangssignale NCK Bit 16...31		0000 0000 0000 0000		
Sichere Eingangssignale Antrieb Bit 16...31		0000 0000 0000 0000		
SGA				Status SI
Sichere Ausgangssignale NCK Bit 0...15		0000 0000 0000 0001		
Sichere Ausgangssignale Antrieb Bit 0...15		0000 0000 0000 0000		
Sichere Ausgangssignale NCK Bit 16...31		0000 0000 0000 0000		
Sichere Ausgangssignale Antrieb Bit 16...31		0000 0000 0000 0000		SGE/SGA
				SPL
Service Achse Service Antrieb Service SI System-ressourcen Konfig.-daten Komm.-protokoll Fahrten-schreiber Version				

Fig. 8-2 Status display of SGE/SGA

The available signals are shown in the diagram above. The vertical softkey Status SI accesses the SI status screen, the SPL softkey accesses the screen for safe programmable logic.

Fig. 5-5 shows the status display of the safe input/output signals.

8.1 Troubleshooting procedure

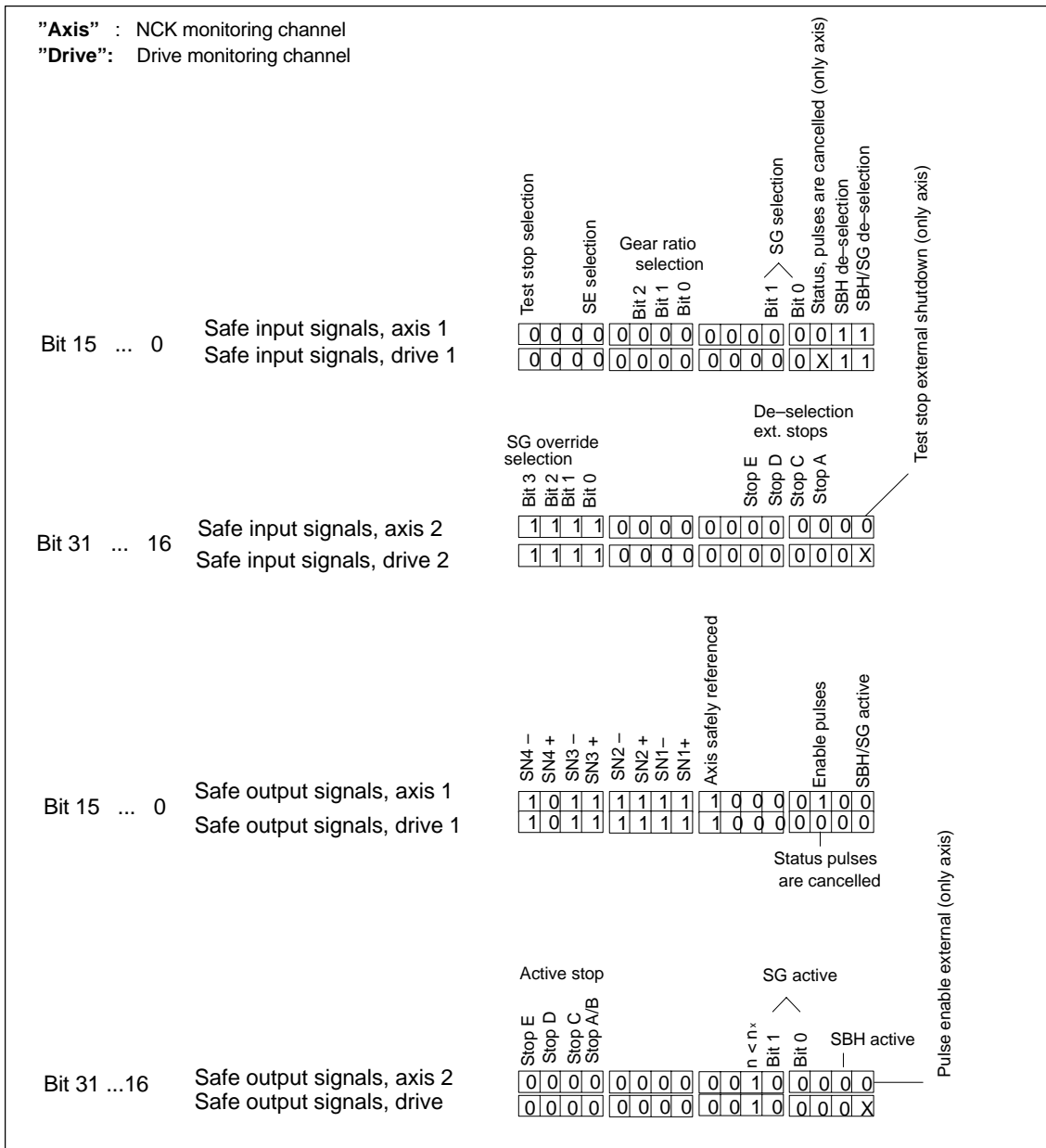

Fig. 8-3 Significance of the status display of the safety-relevant input and output signals

SPL

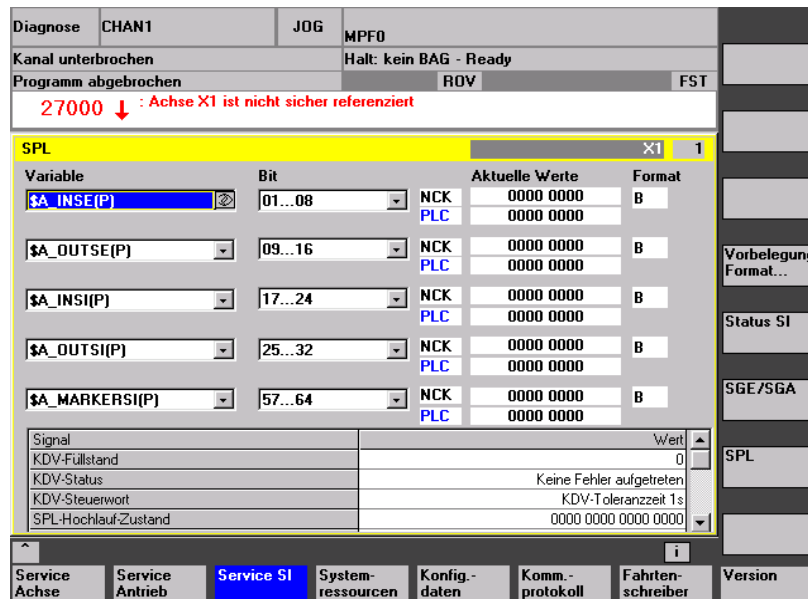

Fig. 8-4 Status display SPL

In the "Variable" selection box, you can select:

\$A_INSE(P) corresponds to simultaneous selection of

\$A_INSE upper line, origin of the NCK and
 \$A_INSEP lower line, origin of the PLC

and effectively the same for the other variables:

\$A_OUTSE(P)
 \$A_INSI(P)
 \$A_OUTSI(P)
 \$A_MARKERSI(P)

The variables that have been selected and the associated bit areas are saved and are taken into account when subsequently selecting the screen.

Using the select key, the following formats can be selected in the variable rows

B Binary
 H Hexadecimal
 D Decimal

The selected format applies for all of the variables displayed in the screen.

8.1.2 Diagnostics support by configuring your own extended alarm text

In order to upgrade the level of diagnostics information when an error occurs, certain Safety Integrated system alarms can be supplemented by a freely-definable user text. For instance, for hardware-related faults, supplementary information such as input designation, circuit diagram identification number or similar can be included in the system alarm that is output.

This extended alarm text is based on the interaction between the NCK system software (that specifies the parameter that addresses the supplementary information for the alarm text) and the HMI software (that has to appropriately process this parameter).

Dedicated extended alarm texts can be defined for the following Safety Integrated system alarms:

- General SPL crosswise data comparison errors (different status of the SPL variables) Alarm 27090, error for crosswise data comparison, NCK-PLC
Extended alarm text is available from NCU system software 05.03.25 and 06.03.01)
- Channel-related errors on the PROFIsafe module (only when using the PROFIsafe I/O)
Alarm 27254 PROFIsafe: F module, error in the channel
Extended alarm text available from NCU system software 06.04.15

Prerequisites, HMI Advanced

The following entry is in the configuration file for the alarm server (file MBDDE.INI) in the section [Text files]:

File excerpt: mbdde.ini

```
[Textfiles]
```

```
NCK=f:\dh\mb.dir\aln_      ; Example : Standard entry
```

This means that all of the NCK alarms are defined in the file referenced after the NCK entry. The processing of an extended alarm text for the above specified alarms is prepared as part of this definition.

File excerpt: aln_gr.com

```
027090 0 0 "Error for crosswise data comparison NCK-PLC, %1[%2], NCK:
%3; %4<ALSI>"
```

```
027254 0 0 "PROFIsafe: F module %1, error in channel %2; %3<ALSI>"
```

Using the supplement %4<ALSI> (Alarm 27090) and %3<ALSI> (Alarm 27254), an extended alarm test can be defined for an alarm. If required, this entry can be subsequently entered into older HMI software versions, in order to activate the display of the extended alarm text – under the assumption that the NCK system software supports this.

Principle of operation – extended alarm text

If Alarm 27090 or Alarm 27254 occurs, the NCK transfers an additional parameter value to the HMI software (27090: %4; 27254: %3). This parameter has a defined value range. Each value can be uniquely assigned an extended alarm text.

Value range of the transfer parameter

000

Parameterizing error detected at run-up (different state active)

Crosswise data comparison error, SPL protective mechanism: MD 11500 – DB18.DBX36.0

Crosswise data comparison error, stop response for SPL error: MD 10097 – DB18.DBX36.1

001...064

Error in system variables \$A_INSE(P)[01...64] (Alarm 27090/Alarm 27254)

If the safety-related input signal is taken from a PROFIsafe module, then only one safe signal state is transferred to the NCK and PLC. This means that internally, a different state no longer occurs between \$A_INSE and \$A_INSEP. The index value then results from a channel error signaled from the PROFIsafe module (Alarm 27254), that is assigned the appropriate \$A_INSE(P) variable (e.g. discrepancy error)

065...128

Error in the system variables \$A_OUTSE(P)[01...64] (Alarm 27090/Alarm 27254).

If the safety-relevant output signal is output to a PROFIsafe module only a safety-relevant signal state is transferred. Alarm 27090 indicates an internal logic error (\$A_OUTSE(P) variables are different) and Alarm 27254 indicates a channel error signaled from a PROFIsafe module, that is assigned the corresponding \$A_OUTSE(P) variable (e.g. short-circuit fault)

129...192

Error in system variables \$A_INSI(P)[01...64] (only alarm 27090)

193...256

Error in system variables \$A_OUTSI(P)[01...64] (only alarm 27090)

257...320

Error in system variables \$A_MARKERSI(P)[01...64] (only alarm 27090)

8.1 Troubleshooting procedure

Definition of the extended text

The file, in which the extended texts are defined, is also declared in the configuration file for the alarm server (file MBDDE.INI) in the section [IndexTextFiles].

File excerpt: mbdde.ini

```
[IndexTextfiles]
ALSI=f:\dh\mb.dir\alsi_ ; Example : Standard entry
```

We recommend that this file for the extended text is located in the HMI user directory.

Every parameter can be assigned a dedicated text in this file, whereby the text entry is located in front of the associated parameter value (refer to the following file excerpt).

File excerpt: alsigr.com

```
000000 0 0 "Parameterizing error MD11500/DB18.DBX36.0 or
           MD10097/DB18.DBX36.1"

000001 0 0 "User text $A_INSE(P) [01]"
..
000064 0 0 "User text $A_INSE(P) [64]"
000065 0 0 "User text $A_OUTSE(P) [01]"
..
000128 0 0 "User text $A_OUTSE(P) [64]"
000129 0 0 "User text $A_INSI(P) [01]"

000192 0 0 "User text $A_INSI(P) [64]"
000193 0 0 "User text $A_OUTSI(P) [01]"

000256 0 0 "User text $A_OUTSI(P) [64]"
000257 0 0 "User text $A_OUTSI(P) [01]"
000320 0 0 "User text $A_OUTSI(P) [64]"
```

The assigned user text is then displayed when Alarms 27090 or 27254 occur, referred to the associated SPL variable.

8.1.3 Servo trace bit graphics for Safety Integrated

General

The servo trace function is one of the measuring functions in the start-up area. Using the servo trace, for drive signals and NCK signals, measurements can be started by entering a measuring time and trigger conditions. The results of the measurements are then graphically displayed. Two curves can be displayed in 2 graphics. The results of the measurements can be saved in files. Further, the graphics can be saved as bitmap file in the HMI_ADV data manager – or directly printed out.

Starting the servo trace

After MMCWIN has been started, the start-up area can be reached using the horizontal "Start-up" softkey (also refer to Chapter 5.3).

After this softkey has been pressed, one menu level lower can be accessed and the servo trace reached by pressing the horizontal "drives/servo" softkey. The basic servo trace display appears after pressing the horizontal servo trace softkey:

Inbetriebnahme	CHAN1	JOG	MPFO					
Kanal unterbrochen			Halt: kein BAG - Ready					Achse +
Programm abgebrochen			ROV	FST				Achse -
27000 ↓ : Achse X1 ist nicht sicher referenziert								
Servo-Trace-Messung								
Signalauswahl								
Trace:	Achs-/Spindelname:		Signalauswahl:		Status:			
Trace 1:	X1		SGE-NCK		aktiv			Start
Trace 2:	X1		SGA-NCK		aktiv			Stop
Trace 3:	X1		SGE Antrieb (von PLC)		aktiv			Physikal. Adresse...
Trace 4:	X1		ext. NCK-SPL-SST Eing. Bit 0...31		aktiv			
Messparameter								
Messdauer:	4000	ms	Trigger:	Kein Trigger				
Triggerzeit:	0	ms	Schwelle:	0.000	#			
^ Servo-Trace-Funktion getriggert								
Messung	Service Achse	Achs-MD	Antriebs-MD		Anwendersichten	Anzeige		Dateifunktionen

8.1 Troubleshooting procedure

Selecting signals

When selecting signals, axes and signal names can be selected from the appropriate lists for a maximum of 4 trace channels (trace 1 to trace 4). Trace 1 has a special significance – a signal must be selected in trace 1 otherwise when the PI service is started using the vertical "start" softkey, this is negatively acknowledged from the NCK.

Measuring parameters

For the measuring parameters, the measuring time, the trigger time, specific thresholds and various trigger signals can be set (e.g. a trigger from the part program). These settings are used to parameterize the PI services at the NCK using the vertical "start" softkey. A measurement that has already been started can be interrupted using the vertical "stop" softkey. In this case, the NCK does not supply any measured values.

Physical address

If the physical address entry is selected in the signal selection list, the vertical softkey having the same name is activated. Using the input masks under this softkey, segment values and offset values of NCK system variables etc. can be specified and then measured.

It is possible to scroll over the axes and spindles in the application using the vertical "Axis +" and "Axis –" softkeys. The axis name or spindle name is included in the selected selection list for the axis/spindle names.

Selecting SGE drive

The selection of the SI signal SGE drive (from the PLC) is shown in the following:

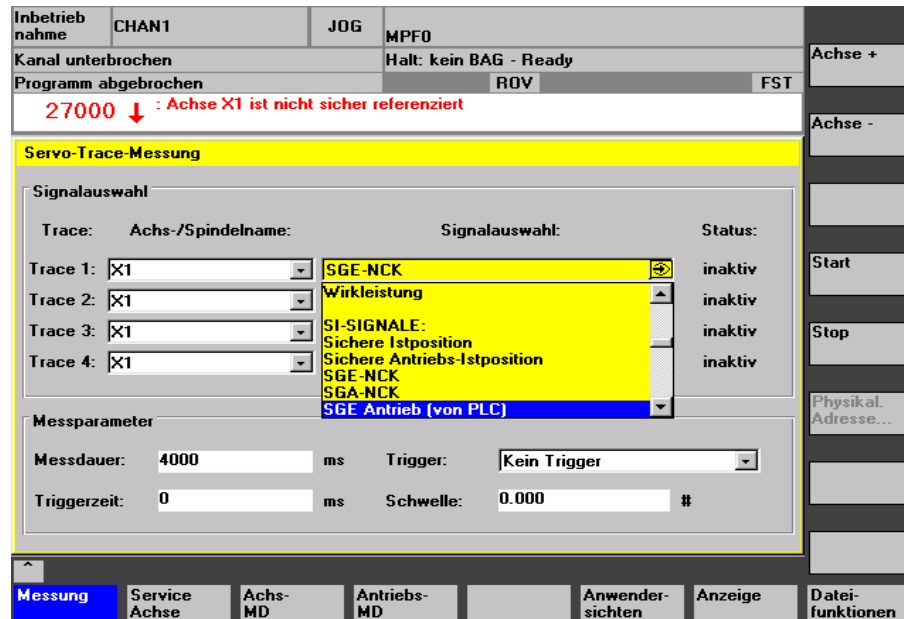

After the vertical "start" softkey is pressed, the measurement is started on the NCK side. An appropriate note is output in the message line.

If the measurement cannot be started, appropriate error information is output. This information can be used to pinpoint the problem.

When the buffers are being transferred, this is signaled in the dialog line.

Display

Once the measurement has been completed, the results of the measurement can be graphically displayed using the horizontal "display" softkey:

8.1 Troubleshooting procedure

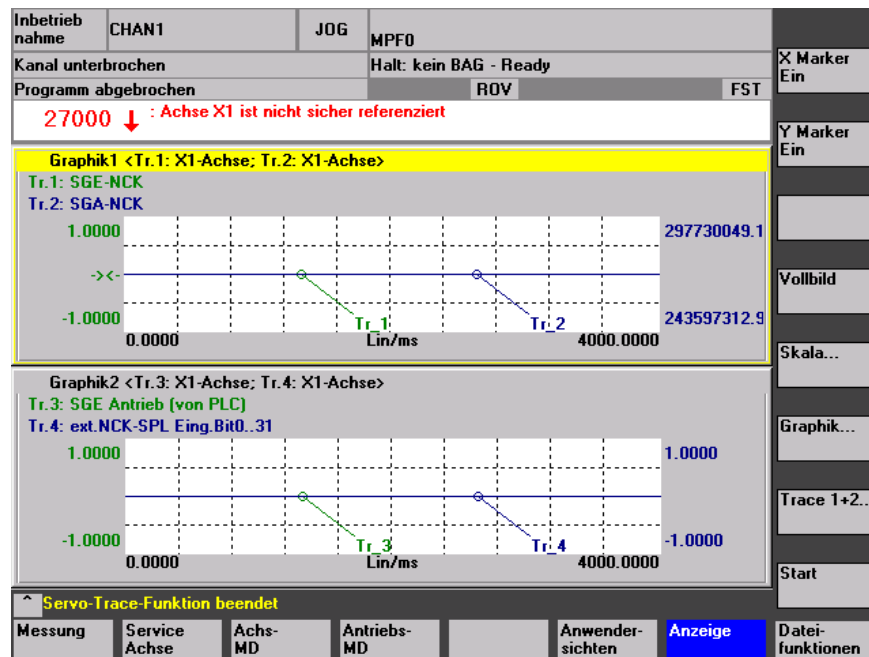

Graphics

Two graphics (graphic 1 and graphic 2) are displayed. Each graphic can include up to two measured value curves that are color-coded (trace 1 in graphic 1: green, trace 2 in graphic 1: blue, trace 3 in graphic 2: green, trace 4 in graphic 2: blue)

Trace 1 and trace 2 are displayed in graphic 1, trace 3 and trace 4 in in graphic 2. The X axis of the graphics is the time axis and the Y axis is scaled in the physical units of the particular signal.

File functions

Measurement settings and the measured values of the servo trace functions can be saved, downloaded or deleted using the horizontal "file functions" softkey. A detailed description will not be provided here. More detailed information can be found in the following document

Reference: /IAD/, Commissioning Manual, SINUMERIK 840D, Chapter 10

8.1.4 Bit graphics for SI signals in the servo trace

Using the servo trace, individual bits can be selected from bit-coded SI signals and the characteristic over time can be graphically displayed similar to a logic analyzer. Bit characteristics can be displayed as a function of time for 10 character channels (tracks).

Bit-coded SI signals

The bit-coded SI signals are principally sub-divided into two groups:

- SI signals where the system allocates the names of the bits (signals: SGE-NCK, SGA-NCK, SGE-PLC and SGA-PLC)
- SI signals where the user can freely select their names and default names are entered into an Ini file (hmi_adv\ibsvtsi.ini). If the user wishes to change the default assignment, he can do this in the file hmi_adv\ibsvtsi.ini or using the appropriate forms in the operator interface.

These different bit-coded SI signals are parameterized on the operator interface.

The settings do not modify the measurement but only how the results of the measurement are actually displayed in the graphic.

No bit graphics are generated for SI signals that are not bit-coded.

Bit selection

The setting options are accessed using the vertical "bit selection..." softkey:

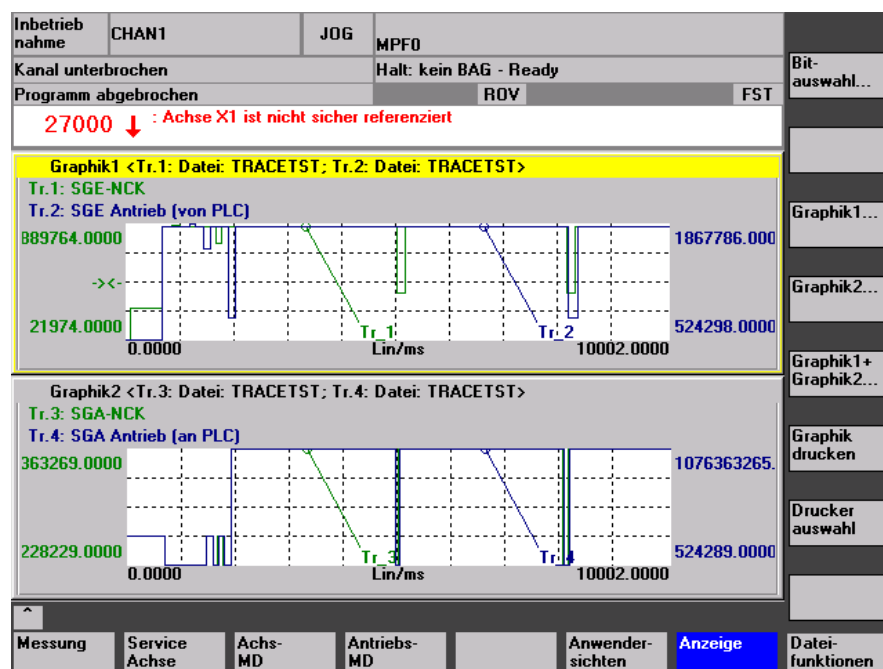

8.1 Troubleshooting procedure

The following screen appears after pressing the vertical "Bit selection..." softkey:

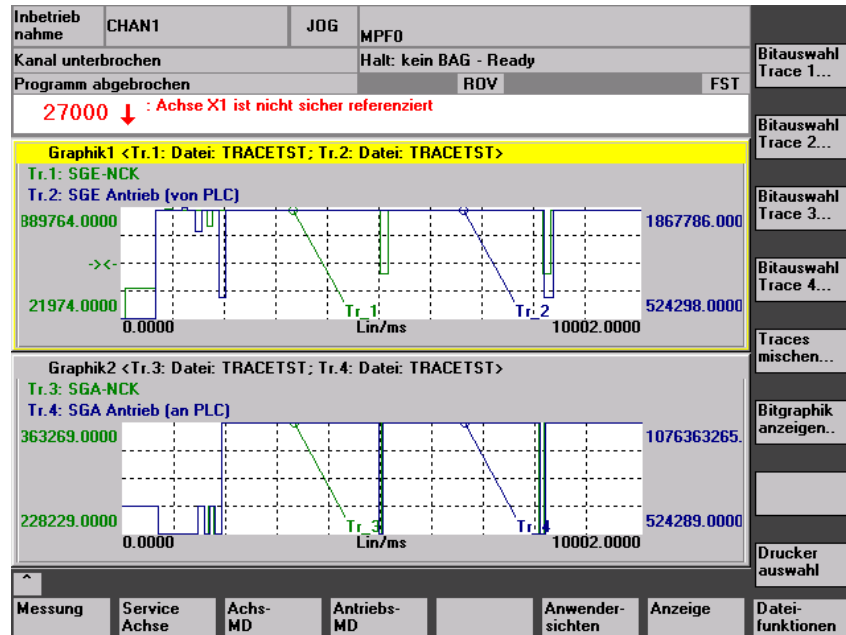

The vertical "Bit selection trace 1...", "Bit selection trace 2...", "Bit selection trace 3..." and "Bit selection trace 4..." softkeys provided allow, for the SI signals selected in trace channels trace 1 to trace 4, bit names of these SI signals to be assigned a possible 10 character channels (tracks) in the bit graphics for these signals. A dedicated graphic is displayed for trace 1, trace 2, trace 3 and trace 4.

If a bit-coded SI signal is not selected in a trace channel, then when the corresponding softkey is pressed, it has no effect; information is output in the dialog line to signal that it does not involve a bit-coded SI signal.

Bit selection, trace 1...

In the example, the signal **SGE–NCK** has been read–in to graphic 1 for trace 1. The following screen is displayed when the vertical "Bit selection trace 1..." softkey is pressed:

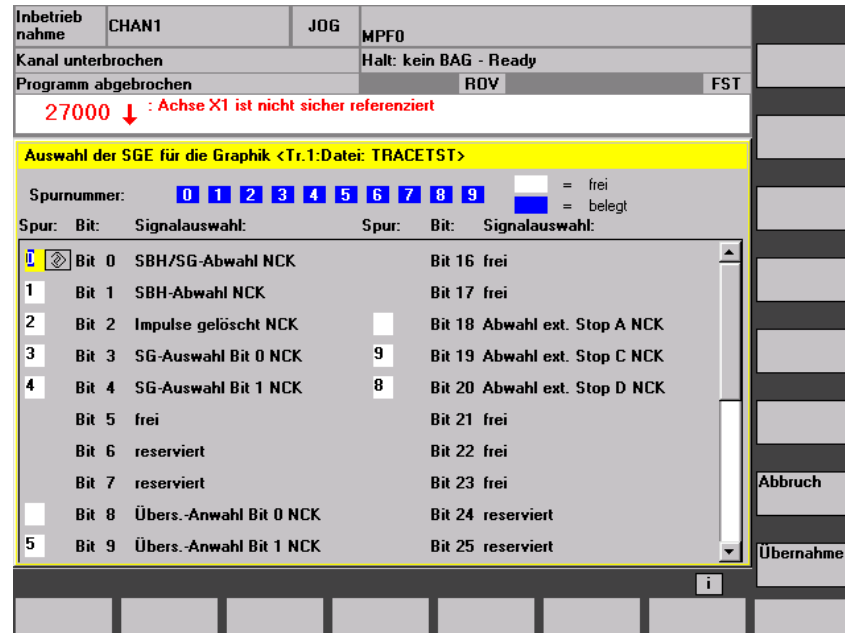

The bits of this signal are consecutively numbered. Every bit is permanently assigned an associated bit name. In the input box "track", by assigning a value in the range between 0..9 it is possible to define in which of the 10 character channels (tracks) the bit should be graphically displayed. In the example, for trace 1, *bit 0 SBH/SD de–selection NCK* is displayed in track 0 of the bit graphic. *Bit 19 de–selection ext. Stop C NCK* is displayed in track 9 of the bit graphic for trace 1.

The user is shown which track numbers have already been allocated (in the label "track number:" they have a blue background) If a track number is allocated twice, an error message is displayed. All of the signal bits are listed; bits that are not available are either designated as free or reserved. Using the scrollbar, it is possible to scroll over the bit range from 0 to bit 31.

Starting values for the track assignments have been entered into the file hmi_adv\libsvt.si.ini. If the user does not like these, then he can make the appropriate changes. These changes to the bit graphics become effective by pressing the vertical "Accept" softkey and are also transferred into the file hmi_adv\libsvt.si.ini as new starting values. This means that they also apply for new measurements with this signal as default settings.

Using the vertical "Abort" softkey, the screen is exited without accepting possible changes made to values.

8.1 Troubleshooting procedure

Bit selection, trace 2... to trace 4...

A similar procedure is also obtained for trace 2.. to trace 4 that, in this particular example, contains the following signals:

Trace 2	SGE drive (from PLC)
Trace 3	SGA-NCK
Trace 4	SG drive (from PLC)

The handling is the same as described under bit selection, trace 1.

Mixing traces...

Using the vertical softkey "Mix traces...", the user can select individual bits of SI signals from 4 traces and display these in the tracks as bit graphics for comparison purposes. This means that especially inputs and outputs of various SI signals can be combined.

8.2 Alarms for Sinumerik 840D

Alarms for SINUMERIK 840D/611digital

Detailed explanations of all alarms that are not described here can be found in the following references for the SINUMERIK 840D system with SIMODRIVE 611digital:

References: /DA/, Diagnostics Manual

Note

For systems with HMI Embedded, the alarms are also explained in the online help.

Alarms for SINUMERIK Safety Integrated

Alarms that may occur in conjunction with Safety Integrated are listed below:

20095	Axis %1 illegal torque, current torque %2
Parameters	%1 = axis name, spindle number %2 = measured holding torque when selecting the brake test
Explanation	The actually measured holding torque, when brake test selected, cannot be attained with the present parameterization of the brake test.
Response	Alarm display The function test of the mechanical brake system is aborted The PLC block FB11 for the sequence control to test the mechanical brake system is exited with a fault (fault detection = 2). This means that the request – "start brake test" – isn't even effective for the axis.
Remedy	Check the parameterization for the brake test function: <ul style="list-style-type: none"> – The torque for weight equalization in drive machine data 1192 should be approximately the same as the actual holding torque. The actual holding torque is displayed in the alarm text. – The specified torque for the brake test \$MA_SAFE_BRAKETEST_TORQUE must be set higher than the actual holding torque.
Program continuation	Clear the alarm with the Clear key or with NC-START.

20096	Axis %1 brake test aborted, additional info %2
Parameters	%1 = axis name, spindle number %2 = fault information, based on \$VA_FXS_INFO
Explanation	The brake test has detected a problem. The additional information provides details of the cause of the alarm. An explanation is provided in the documentation about the system variables \$VA_FXS_INFO Supplementary info: 0: No additional information available 1: Axis type is neither a PLC nor a command axis 2: Limit position reached, motion stopped 3: Abort using NC–RESET (key reset) 4: Monitoring window exited 5: Torque reduction rejected by drive 6: PLC has withdrawn the enable signal
Response	Alarm display Interface signals are set.
Remedy	Note the limitations/constraints of the brake test, refer to supplementary info.
Program continuation	Clear the alarm with the Clear key or with NC–START.

20097	Axis %1 incorrect traversing direction brake test
Parameters	%1 = axis name, spindle number
Explanation	As a result of the selected traversing direction, the brake test is carried-out for the existing load torque with an incorrect torque.
Response	Alarm display
Remedy	<ul style="list-style-type: none"> – Carry-out the brake test in the other traversing direction – Adapt drive MD 1192 more precisely to the actual situation. This alarm only occurs – with the brake open – if the actual torque deviates by more than 5% from MD 1192 – Using MD \$MA_SAFE_BRAKETEST_CONTROL, bit 0 = 1, activate the automatic load torque determination at the beginning of the brake test.
Program continuation	Clear the alarm with the Clear key or with NC-START.
27000	Axis %1 is not safely referenced
Parameters	%1 axis number
Explanation	<p>There are two reasons for this alarm:</p> <ul style="list-style-type: none"> – The user has still not acknowledged the machine position, – the machine position has still not been verified by subsequent referencing. <p>Even if the axis is already referenced there is no acknowledgment that referencing has supplied the correct result. For example, incorrect results can occur if the axis was moved after the control was powered-down – with the result that the standstill position saved prior to powering-down is no longer correct. To ensure that this does not happen, the user must acknowledge the displayed actual position after the first referencing operation.</p> <p>After the user agreement has been set for the first time, the axis must be subsequently referenced each time that the control is run-up (with absolute encoders, this subsequent referencing is automatically executed). This procedure is carried-out to verify the standstill position saved prior to powering-down the control.</p> <p>The alarm display can be set using MD \$MN_SAFE_ALARM_SUPPRESS_LEVEL (MD>=3) so that the group alarm 27100 is displayed for all SI axes.</p>
Response	Alarm display
Remedy	<p>Move the axis to a known position, change to the "referencing" mode and press the softkey "Agreement". Check the positions in the agreement screen at the machine. If these correspond to those expected at the known position, confirm this using the toggle key. If the user agreement has already been set, re-reference the axis.</p> <p>The user agreement can only be changed in key-actuated switch setting 3 or after entering a password.</p>
Program continuation	The alarm is no longer displayed when the alarm cause has been removed. No other operator actions are required

**Warning**

If the axis has not been safely referenced and the user has not issued a user agreement, then the following applies:

- the safe cams are still not safe.
- the safe limit positions are still not active

27001	Axis %1 error in a monitoring channel, Code %2, values: NCK %3, drive %4
Parameters	<p>%1 = axis number %2 = supplementary information, crosswise data comparison index %3 = supplementary information, comparison value, NCK %4 = supplementary information, comparison value, drive</p>
Explanation	<p>The status of the safety-related monitoring functions are cyclically and mutually compared between the two monitoring channels (NCK and drive). The comparison is carried-out separately for each NCK/drive combination.</p> <p>A criterion in a comparison list is compared between the NCK and drive in each monitoring clock cycle (MD 10091); the next criterion is compared in the next monitoring clock cycle etc. Once the complete comparison list has been processed, the comparisons are processed again from the start. The total comparison time to process the list is displayed in MD 10092 (factor x MD 10091 – the factor can differ depending on the SW version).</p> <p>The "Error in a monitoring channel" Alarm is only output if the mutual comparison of the two monitoring channels detects a difference between the input data or results of the monitoring. One of the monitoring functions no longer operates reliably.</p> <p>The crosswise comparison index, output under %2, is also known as STOP F code. The STOP F code is also output in Alarm 27001 where the NCK detected a crosswise comparison error <u>for the first time</u>. The STOP F code of the drive (belonging to Alarm 300911) can be taken from the diagnostics screen or the drive machine data MD 1395. If a difference is detected at several comparison steps, then also several STOP F code values can be displayed, alternating, at these positions. There are fault profiles that are identified as a result of several comparison operations of the comparison list. This means that the displayed STOP F code value doesn't always provide a clear statement regarding the cause of the fault. The associated procedure is then explained for each of the individual fault codes.</p> <p>The following STOP F codes are possible for the NCK (and drive):</p>

– 0

No fault/error has been detected in this monitoring channel.

For Alarm 27001 this means that it was one of the subsequent alarms (follow-on alarms) of Alarm 300911 – and the valid STOP F code value is to be determined using the diagnostics display or the drive MD.

– 1

For the monitoring functions SBH, SG or SE, a different state has occurred between the NCK and drive. The actual status image (result list 1) is output from the NCK as supplementary input %3 (comparison value, NCK) and the actual status image from the drive is output as supplementary info %4 (comparison value, drive). The two supplementary infos are also saved in MD 1391 (NCK) and MD 1392 (drive).

An example for evaluating the bit-coded result list is provided in the description of the drive machine data.

Remedy

The difference in the states between the drive and NCK should be determined and the function involved should be investigated in more detail.

Example

State, NCK: SBH is active and ok

State, drive: SG1 is active and ok

The fault is caused due to the fact that the SGE "SBH de-selection" is controlled differently. The signal source should be checked on both the NCK and drive sides. Generally, the different control (in operation) is a result of a hardware failure associated with the sensor signal involved. In the commissioning phase, the cause can also be parameterization or programming errors.

– 2

For the monitoring function SN or n<nx, a different state has occurred between the NCK and drive.

The actual status image of the NCK (result list 2) is output as supplementary info %3 (comparison value NCK) and the actual status image from the drive is output as supplementary info %4 (comparison value, drive). The two result lists are also written into as MD 1393 (NCK) and MD 1394 (drive). An example for evaluating the bit-coded result list is provided in the description of the drive machine data.

Remedy

The difference in the states between the drive and NCK should be determined and the function involved should be investigated in more detail.

– 3

The difference between the safe actual value NCK and drive is greater than that set in MD 36942 \$MA_SAFE_POS_TOL.

When using the actual value synchronization, the difference of the speed (determined based on the safety actual values) is greater than that set in MD 36949 \$MA_SAFE_SLIP_VELO_TOL.

Remedy

Commissioning phase:

The encoder evaluation for the NCK and drive is not correctly set → correct the encoder evaluation.

In operation:

The actual values differ due to mechanical faults (transmission belts, traversing to mechanical limit, wear and tolerance windows that have been set too narrow, encoder faults...)

→ check the mechanical design and the encoder signals

– 4

Not assigned.

– 5

The setting in MD 36901 \$MA_SAFE_FUNCTION_ENABLE does not correspond with the associated drive parameter assignment.

Remedy

Copy SI data

– 6

The setting in MD 36931 \$MA_SAFE_VELO_LIMIT[0] does not correspond with the associated drive parameter assignment.

Remedy

Copy SI data

– 7

The setting in MD 36931 \$MA_SAFE_VELO_LIMIT[1] does not correspond with the associated drive parameter assignment.

Remedy

Copy SI data.

– 8

The setting in MD 36931 \$MA_SAFE_VELO_LIMIT[2] does not correspond with the associated drive parameter assignment.

Remedy

Copy SI data.

– 9

The setting in MD 36931 \$MA_SAFE_VELO_LIMIT[3] does not correspond with the associated drive parameter assignment.

Remedy

Copy SI data.

– 10

The setting in MD 36930 \$MA_SAFE_STANDSTILL_TOL does not correspond with the associated drive parameter assignment.

Remedy

Copy SI data.

– 11

The setting in MD 36934 \$MA_SAFE_POS_LIMIT_PLUS[0] does not correspond with the associated drive parameter assignment.

Remedy

Copy SI data.

– 12

The setting in MD 36935 \$MA_SAFE_POS_LIMIT_MINUS[0] does not correspond with the associated drive parameter assignment.

Remedy

Copy SI data.

– 13

The setting in MD 36934 \$MA_SAFE_POS_LIMIT_PLUS[1] does not correspond with the associated drive parameter assignment.

Remedy

Copy SI data.

– 14

The setting in MD 36935 \$MA_SAFE_POS_LIMIT_MINUS[1] does not correspond with the associated drive parameter assignment.

Remedy

Copy SI data.

– 15

The setting in MD 36936 \$MA_SAFE_CAM_POS_PLUS[0] + MD 36940 \$MA_SAFE_CAM_TOL does not correspond with the associated drive parameter assignment.

Remedy

Copy SI data.

– 16

The setting in MD 36936 \$MA_SAFE_CAM_POS_PLUS[0] does not correspond with the associated drive parameter assignment.

Remedy

Copy SI data.

– 17

The setting in MD 36937 \$MA_SAFE_CAM_POS_MINUS[0] + MD 36940 \$MA_SAFE_CAM_TOL does not correspond with the associated drive parameter assignment.

Remedy

Copy SI data.

– 18

The setting in MD 36937 \$MA_SAFE_CAM_POS_MINUS[0] does not correspond with the associated drive parameter assignment.

Remedy

Copy SI data.

– 19

The setting in MD 36936 \$MA_SAFE_CAM_POS_PLUS[1] + MD 36940 \$MA_SAFE_CAM_TOL does not correspond with the associated drive parameter assignment.

Remedy

Copy SI data.

– 20

The setting in MD 36936 \$MA_SAFE_CAM_POS_PLUS[1] does not correspond with the associated drive parameter assignment.

Remedy

Copy SI data.

– 21

The setting in MD 36937 \$MA_SAFE_CAM_POS_MINUS[1] + \$MA_SAFE_CAM_TOL does not correspond with the associated drive parameter assignment.

Remedy

Copy SI data.

– 22

The setting in MD 36937 \$MA_SAFE_CAM_POS_MINUS[1] does not correspond with the associated drive parameter assignment.

Remedy

Copy SI data.

– 23

The setting in MD 36936 \$MA_SAFE_CAM_POS_PLUS[2] + MD 36940 \$MA_SAFE_CAM_TOL does not correspond with the associated drive parameter assignment.

Remedy

Copy SI data.

– 24

The setting in MD 36936 \$MA_SAFE_CAM_POS_PLUS[2] does not correspond with the associated drive parameter assignment.

Remedy

Copy SI data.

– 25

The setting in MD 36937 \$MA_SAFE_CAM_POS_MINUS[2] + MD 36940 \$MA_SAFE_CAM_TOL does not correspond with the associated drive parameter assignment.

Remedy

Copy SI data.

– 26

The setting in MD 36937 \$MA_SAFE_CAM_POS_MINUS[2] does not correspond with the associated drive parameter assignment.

Remedy

Copy SI data.

– 27

The setting in MD 36936 \$MA_SAFE_CAM_POS_PLUS[3] + MD 36940 \$MA_SAFE_CAM_TOL does not correspond with the associated drive parameter assignment.

Remedy

Copy SI data.

– 28

The setting in MD 36936 \$MA_SAFE_CAM_POS_PLUS[3] does not correspond with the associated drive parameter assignment.

Remedy

Copy SI data.

– 29

The setting in MD 36937 \$MA_SAFE_CAM_POS_MINUS[3] + MD 36940 \$MA_SAFE_CAM_TOL does not correspond with the associated drive parameter assignment.

Remedy

Copy SI data.

– 30

The setting in MD 36937 \$MA_SAFE_CAM_POS_MINUS[3] does not correspond with the associated drive parameter assignment.

Remedy

Copy SI data.

– 31

The settings in MD 36942 \$MA_SAFE_POS_TOL. and MD 36949 \$MA_SAFE_SLIP_VELO_TOL do not correspond with the associated drive parameter assignment.

Remedy

Copy SI data.

– 32

The setting in MD 36944 \$MA_SAFE_REFP_POS_TOL does not correspond with the associated drive parameter assignment.

Remedy

Copy SI data.

– 33

The setting in MD 36951 \$MA_SAFE_VELO_SWITCH_DELAY does not correspond with the associated drive parameter assignment.

Remedy

Copy SI data.

– 34

The setting in MD 36950 \$MA_SAFE_MODE_SWITCH_TIME does not correspond with the associated drive parameter assignment.

Remedy

Copy SI data.

– 35

The setting in MD 36956 \$MA_SAFE_PULSE_DISABLE_DELAY does not correspond with the associated drive parameter assignment.

Remedy

Copy SI data.

– 36

The setting in MD 36957 \$MA_SAFE_PULSE_DIS_CHECK_TIME does not correspond with the associated drive parameter assignment.

Remedy

Copy SI data.

– 37

The setting in MD 36952 \$MA_SAFE_STOP_SWITCH_TIME_C does not correspond with the associated drive parameter assignment.

Remedy

Copy SI data.

– 38

The setting in MD 36953 \$MA_SAFE_STOP_SWITCH_TIME_D does not correspond with the associated drive parameter assignment.

Remedy

Copy SI data.

– 39

The setting in MD 36954 \$MA_SAFE_STOP_SWITCH_TIME_E does not correspond with the associated drive parameter assignment.

Remedy

Copy SI data.

– 40

The setting in MD 36961 \$MA_SAFE_VELO_STOP_MODE does not correspond with the associated drive parameter assignment.

Remedy

Copy SI data.

– 41

The setting in MD 36962 \$MA_SAFE_POS_STOP_MODE does not correspond with the associated drive parameter assignment.

Remedy

Copy SI data.

– 42

The setting in MD 36960 \$MA_SAFE_STANDSTILL_VELO_TOL does not correspond with the associated drive parameter assignment.

Remedy

Copy SI data.

– 43

Stop response, memory test.

44 – 57**Explanation**

Fault codes 44–57 cannot be clearly assigned to a fault cause. For the monitoring functions that run internally (e.g. SG), monitoring limits are internally generated that are referred to a monitoring clock cycle.

Example:

SG1 = 2000 mm/min, monitoring clock cycle = 12 ms

If SG1 is active, then a check is made in every monitoring clock cycle (MCC) as to whether SG1 was exceeded.

This means that in MCC[n], based on the actual value, a positive and negative actual value limit is defined that may not be exceeded in MCC[n+1] in order to still comply with SG1.

SG1 = 2000 mm/min = 33.33 mm/s = 0.4 mm/MCC (for each 12 ms)

If the axis moves more than 0.4 mm in a monitoring clock cycle, then SG1 would be violated.

The limit values, specified above, in MCC[n+1] are then

positive: position actual value (MCC[n]) + 0.4 mm

negative: position actual value (MCC[n]) – 0.4 mm

The resulting monitoring limits (positive and negative) that are, in turn determined independently for both monitoring channels (NCK and drive) are also compared just like the safe actual positions (refer to fault code 3). The comparison is for a difference < MD 36942

\$MA_SAFE_POS_TOL.

If the difference is greater than MD 36942 \$MA_SAFE_POS_TOL, then the appropriate fault code is output.

The limit values are then re-generated and compared in every monitoring cycle independently of whether the associated monitoring function is active or not.

This means that there are three possible causes for this fault code group.

Causes and remedy*Possible cause 1 (only when commissioning or changing the MD)*

The tolerance value for the monitoring function is set differently for the NCK and drive. This situation actually only occurs when commissioning the system or making changes and is generally already covered by the previous fault codes.

Remedy: Set the relevant machine data the same.

Possible cause 2 (in operation)

The limit values are determined based on the actual value. This means that when the safe actual values of the NCK and drive differ then the limit values are also different by the defined clearance → i.e. the fault code corresponds to the fault image of fault code 3. This can be determined by checking the safe actual positions.

Remedy: Refer to fault code 3.

Possible cause 3 (in operation)

The associated monitoring function is already active in a monitoring channel – while in the other monitoring channel another monitoring function is still active. This is the case if the safe actual positions of the NCK and drive do not differ but instead there is an entry in the drive MD 1391/1392 (and the 1 appears in MD 1395) → i.e. the fault code corresponds to the fault profile of fault code 1. This can also be identified using the fault message if as %3 = supplementary info comparison value NCK or %4 = supplementary info comparison value drive no real limit value is output but only the value of the calculated tolerance (refer to the example above = 400).

Remedy: Refer to fault code 1.

– 44

Upper limit value for SG1 = position actual value + MD 36931
\$MA_SAFE_VELO_LIMIT[0] referred to a monitoring clock cycle

Remedy

Refer to Section 44–57 (hidden fault code **3** or **1**)

– 45

Lower limit value for SG1 = position actual value – MD 36931
\$MA_SAFE_VELO_LIMIT[0] referred to a monitoring clock cycle

Remedy

Refer to Section 44–57 (hidden fault code **3** or **1**)

– 46

Upper limit value for SG2 = position actual value + MD 36931
\$MA_SAFE_VELO_LIMIT[1] referred to a monitoring clock cycle

Remedy

Refer to Section 44–57 (hidden fault code **3** or **1**)

– 47

Lower limit value for SG2 = position actual value – MD 36931
\$MA_SAFE_VELO_LIMIT[1] referred to a monitoring clock cycle

Remedy

Refer to Section 44–57 (hidden fault code **3** or **1**)

– 48

Upper limit value for SG3 = position actual value + MD 36931
\$MA_SAFE_VELO_LIMIT[2] referred to a monitoring clock cycle

Remedy

Refer to Section 44–57 (hidden fault code **3** or 1)

– 49

Lower limit value for SG3 = position actual value – MD 36931
\$MA_SAFE_VELO_LIMIT[2] referred to a monitoring clock cycle

Remedy

Refer to Section 44–57 (hidden fault code **3** or 1)

– 50

Upper limit value for SG4 = position actual value + MD 36931
\$MA_SAFE_VELO_LIMIT[3] referred to a monitoring clock cycle

Remedy

Refer to Section 44–57 (hidden fault code **3** or 1)

– 51

Lower limit value for SG4 = position actual value – MD 36931
\$MA_SAFE_VELO_LIMIT[3] referred to a monitoring clock cycle

Remedy

Refer to Section 44–57 (hidden fault code **3** or 1)

– 52

Upper limit value for SBH
Position actual value (when SBH is activated) + MD 36930
\$MA_SAFE_STANDSTILL_TOL.

Remedy

Refer to Section 44–57 (hidden fault code **3** or 1)

– 53

Lower limit value for SBH
Position actual value (when SBH is activated) – MD 36930
\$MA_SAFE_STANDSTILL_TOL.

Remedy

Refer to Section 44–57 (hidden fault code **3** or 1)

– 54

Upper limit value for n<nx (plus tolerance)
Position actual value + MD 36946 \$MA_SAFE_VELO_X (referred to a
monitoring clock cycle) + MD 36942 \$MA_SAFE_POS_TOL.

Remedy

Refer to Section 44–57 (hidden fault code **3** or 1)

– 55

Upper limit value for n<nx
Position actual value + MD 36946 \$MA_SAFE_VELO_X (referred to a
monitoring clock cycle).

Remedy

Refer to Section 44–57 (hidden fault code **3** or 1)

– 56

Lower limit value for n<nx
Position actual value – MD 36946 \$MA_SAFE_VELO_X (referred to a
monitoring clock cycle).

Remedy

Refer to Section 44–57 (hidden fault code **3** or 1)

– 57

Upper limit value for n<nx (plus tolerance)

Position actual value + MD 36946 \$MA_SAFE_VELO_X–(referred to a monitoring clock cycle) – MD 36942 \$MA_SAFE_POS_TOL.

Remedy

Refer to Section 44–57 (hidden fault code 3 or 1)

– 58

There is a difference in the active request for an external STOP. Two factors determine the resulting external STOP request for a monitoring channel.

- The STOP requested via the SGE interface
- The STOP passed-through from the other monitoring channel

The STOP of the active request is specified as detailed fault code for the NCK and drive.

The following values are possible:

0 = No Stop

1 = Stop F

2 = Stop E

3 = Stop D

4 = Stop C

5 = Stop test

6 = Stop B

7 = Stop A

– 59

The setting in MD 36932 \$MA_SAFE_VELO_OVR_FACTOR[0] does not correspond with the associated drive parameter assignment.

Remedy

Copy SI data.

– 60

The setting in MD 36932 \$MA_SAFE_VELO_OVR_FACTOR[1] does not correspond with the associated drive parameter assignment.

Remedy

Copy SI data.

– 61

The setting in MD 36932 \$MA_SAFE_VELO_OVR_FACTOR[2] does not correspond with the associated drive parameter assignment.

Remedy

Copy SI data.

– 62

The setting in MD 36932 \$MA_SAFE_VELO_OVR_FACTOR[3] does not correspond with the associated drive parameter assignment.

Remedy

Copy SI data.

– 63

The setting in MD 36932 \$MA_SAFE_VELO_OVR_FACTOR[4] does not correspond with the associated drive parameter assignment.

Remedy

Copy SI data.

– 64

The setting in MD 36932 \$MA_SAFE_VELO_OVR_FACTOR[5] does not correspond with the associated drive parameter assignment.

Remedy

Copy SI data.

– 65

The setting in MD 36932 \$MA_SAFE_VELO_OVR_FACTOR[6] does not correspond with the associated drive parameter assignment.

Remedy

Copy SI data.

– 66

The setting in MD 36932 \$MA_SAFE_VELO_OVR_FACTOR[7] does not correspond with the associated drive parameter assignment.

Remedy

Copy SI data.

– 67

The setting in MD 36932 \$MA_SAFE_VELO_OVR_FACTOR[8] does not correspond with the associated drive parameter assignment.

Remedy

Copy SI data.

– 69

The setting in MD 36932 \$MA_SAFE_VELO_OVR_FACTOR[10] does not correspond with the associated drive parameter assignment.

Remedy

Copy SI data.

– 70

The setting in MD 36932 \$MA_SAFE_VELO_OVR_FACTOR[11] does not correspond with the associated drive parameter assignment.

Remedy

Copy SI data.

– 71

The setting in MD 36932 \$MA_SAFE_VELO_OVR_FACTOR[12] does not correspond with the associated drive parameter assignment.

Remedy

Copy SI data.

– 72

The setting in MD 36932 \$MA_SAFE_VELO_OVR_FACTOR[13] does not correspond with the associated drive parameter assignment.

Remedy

Copy SI data.

– 73

The setting in MD 36932 \$MA_SAFE_VELO_OVR_FACTOR[14] does not correspond with the associated drive parameter assignment.

Remedy

Copy SI data.

– 74

The setting in MD 36932 \$MA_SAFE_VELO_OVR_FACTOR[15] does not correspond with the associated drive parameter assignment.

Remedy

Copy SI data.

– 75

The setting in MD 36946 \$MA_SAFE_VELO_X does not correspond with the associated drive parameter assignment.

Remedy

Copy SI data.

– 76

The setting in MD 36963 \$MA_SAFE_VELO_STOP_REACTION[0] does not correspond with the associated drive parameter assignment.

Remedy

Copy SI data.

– 77

The setting in MD 36963 \$MA_SAFE_VELO_STOP_REACTION[1] does not correspond with the associated drive parameter assignment.

Remedy

Copy SI data.

– 78

The setting in MD 36963 \$MA_SAFE_VELO_STOP_REACTION[2] does not correspond with the associated drive parameter assignment.

Remedy

Copy SI data.

– 79

The setting in MD 36963 \$MA_SAFE_VELO_STOP_REACTION[3] does not correspond with the associated drive parameter assignment.

Remedy

Copy SI data.

– 80

The setting in MD 36905 \$MA_SAFE_MODULO_RANGE does not correspond with the associated drive parameter assignment.

Remedy

Copy SI data.

– 81

The setting in MD 36948 \$MA_SAFE_STOP_VELO_TOL does not correspond with the associated drive parameter assignment.

Remedy

Copy SI data.

– 82

When controlling the SG correction factor–SGEs[0..3] to select the SG correction factor a difference has occurred. If, as supplementary info for a monitoring channel, –1 is output this means that the SG–override function isn't even active.

- SG2 and SG4 are not active.
- Function hasn't even been enabled using the function enable MD 36901/1301.

Remedy

Control the SG stage and check the SG–override signals and align the control.

– 83

The setting in MD 36958 \$MA_SAFE_ACCEPTANCE_TST_TIMEOUT does not correspond with the associated drive parameter assignment.

Remedy

Copy SI data.

– 84

The setting in MD 36955 \$MA_SAFE_STOP_SWITCH_TIME_F does not correspond with the associated drive parameter assignment.

Remedy

Copy SI data.

– 85

The setting in MD 10089 \$MN_SAFE_PULSE_DIS_TIME_BUSFAIL does not correspond with the associated drive parameter assignment.

Remedy

Copy SI data.

– 86

Not assigned.

– 87

Not assigned.

– 88

Not assigned.

– 89

The setting in MD 36926 \$MA_SAFE_ENC_FREQ_LIMIT does not correspond with the associated drive parameter assignment.

Remedy

Copy SI data.

– 1000

The checking timer has expired while the change timer has still not expired. If, in a monitoring channel, an SGE changes (e.g. SBH is selected), then the so–called change timer is started (timer value = MD 36950/1350 SAFE_MODE_SWITCH_TIME).

In addition, a so–called checking timer is started in the other channel (timer value = 10xMD 36950).

While the change timer is running, if the same SGE is changed again, the timer value is extended and the checking timer in the other channel only runs once.

If the change timer is extended so often that the run time is greater than for the checking timer (i.e. at least 6x0 → 1 change at the SGE), then the fault is output.

Too many signal changes were detected during the checking timer runtime.

Remedy

Determine the SGE involved and the associated hardware signal and investigate the situation. There may be contact problems at the sensor (e.g. poor contact) or there were too many switching operations. If necessary, the behavior can be improved by changing the timer setting.

– 1001

Only in the drive: Initialization error of the checking timer.

– 1002

The user agreement is not consistent: The status of the user agreement is, after 2 s has expired, different for both monitoring channels.

%3 = status of the user agreement, NCK.

%4 = status of the user agreement, drive

This effect can occur if the user agreement is only set or reset through one channel.

An additional fault cause is that if the F code 1003 only occurs in one monitoring channel and then the user agreement is only withdrawn through one channel. This means that code 1002 is then the result of a code 1003 only in one channel.

– 1003

With the user agreement is set, the difference between the newly determined reference point (NC actual value) after run-up (absolute value encoder) or reference point approach [homing] (distance-coded or incremental measuring system) and the safe actual position (saved value + traversing distance) is greater than the reference tolerance MD 36944/MD 1344 \$MA_SAFE_REFP_POS_TOL. In this case, the user agreement is withdrawn.

Remedy

Check the mechanical system of the axis – it is possible that the axis was moved when powered-down and the actual value last saved by the control no longer corresponds with the new value at the next system run-up. It is also possible that the tolerance window for the check has been set too narrow. The cause should be determined and after checking the actual values the user agreement can be again reset after an NCK-RESET.

– 1004

Violated plausibility, user agreement

- Although the user agreement was already set, an attempt was made to set it again.
- The user agreement is set although the axis has still not been referenced.

– 1005

When activating the SGEs test stop selection, the shutdown path test cannot be carried-out because the pulses have already been cancelled.

Remedy

Check the starting conditions for carrying-out the test and if required, correct. In the commissioning phase, it is also possible that there is incorrect parameterization (or wiring) for the feedback signal regarding pulse cancellation (MD 36975).

– 1006

Only in the drive:

A fault has occurred while cyclically checking the read, write access to the SGA interface of the drive.

Remedy

Replace the hardware, drive control

– 1007

Only in the drive:

Cyclic communications between the PLC and drive have failed.

Remedy

If required, replace the hardware, drive control.

Check the drive bus and PLC

– 1008

Only in the drive:

Data transfer error between the PLC and drive.

Remedy

If required, replace the hardware, drive control.

Check the drive bus and PLC

– 1009

After activating the SGEs test stop selection, the pulses have still not been cancelled after timer MD 36957/1357

\$MA_SAFE_PULSE_DIS_CHECK_TIME has elapsed.

Remedy

- Check the parameterization and wiring for the SGE MD 36976 SAFE_PULSE_STATUS_INPUT.
- Check the parameterization and wiring for the SGA MD 36986 SAFE_PULSE_STATUS_OUTPUT (e.g. an incorrect reference potential has been selected for the enable signals).
- Check the parameterization for the timer – it is possible that the value has been selected too low.

– 1010

After activating the SGEs test stop selection external, the pulses have still not been cancelled after the timer MD 36957/1357

\$MA_SAFE_PULSE_DIS_CHECK_TIME has expired.

Remedy

- Check the parameterization and wiring for the SGE MD 36976 SAFE_PULSE_STATUS_INPUT.
- Check the parameterization and wiring for the SGA MD 36986 SAFE_PULSE_STATUS_OUTPUT (e.g. an incorrect reference potential has been selected for the enable signals).
- Check the parameterization for the timer – it is possible that the value has been selected too low.

– 1011

The internal status "acceptance test status" when using the acceptance test support indicates different states for the NCK/drive for at least 2 seconds.

– 1020

Cyclic communications between the NCK and drive no longer functions.

Response	NC start inhibit in this channel Alarm display If a safety monitoring function was active (SBH, SG, SE, SN), then a STOP B was also automatically initiated. It is then necessary to power-down/power-up the control (power on).
Program continuation	Clear the alarm with the RESET key. Restart the part program. If a STOP B was initiated, then the control must be powered-down/power-up (power on).

27002 Axis %1 Test stop in progress

Parameters	%1 = axis number
Explanation	The proper and correct functioning of the shutdown path is presently being tested by setting the SGE "test stop selection".
Response	Alarm display
Remedy	This message only provides information for the user.
Program continuation	The alarm is no longer displayed when the alarm cause has been removed. No other operator actions are required. The alarm automatically disappears after the delay time has expired that is defined in MD \$MA_SAFE_PULSE_DIS_CHECK_TIME – and the withdrawal of the SGE "test stop selection" if the control detects that the drive pulses have been cancelled – i.e. the test has been successfully completed. An unsuccessful test can be recognized as a result of Alarm 27001 with fault code 1005 or Alarm 27024.

27003 Checksum error occurred %1 %2

Parameters	%1 = reference to the code section or table %2 = table number
Explanation	Checksum error in safety-related code or safety-related data. The safety monitoring functions (Safety Integrated) in the NCK could be corrupted.
Response	Alarm display
Remedy	Please take extreme caution when continuing with any work. Re-load code and data as soon as possible (power on). If this fault occurs again, contact the service department.
Program continuation	Switch control system OFF and ON again.

27004	Axis %1 difference safe input %2, NCK %3, drive %4
Parameters	<p>%1 = axis number %2 = monitoring function involved %3 = interface identifier, NCK input %4 = interface identifier, drive input</p>
Explanation	<p>A difference has been detected at the specified safe input. The state of the specified input signal differs in the two monitoring channels NCK and 611D during the time set in \$MA_SAFE_MODE_SWITCH_TIME. Monitoring function involved (%2):</p> <p>SS/SV Difference in SGE "de-select safe operating stop/ safely-reduced speed" SS Difference in SGE "de-select safe operating stop" SV Difference in SGE "select safely-reduced speed" SP Difference in SGE "select safe limit positions" SVOVR Difference in SGEs "select SG correction"</p> <p>Interface identifier NCK input (%3): DMP<drv><mod><bit>=<value> <drv> = drive number of the terminal block (1...31) <mod> = sub-module number (1...8) <bit> = connection number (1...16) <value> = value of the NCK-SGE (0,1) SPL for the case that SGE is parameterized at the</p> <p>SPL interface. <io> = parameterized system variable range (01=\$A_INSID, 02=\$A_INSED) <dword> = system variable – double word (1,2) <bit> = bit number in the system variable – double word (1...32) <value> = value of the NCK-SGE (0,1)</p> <p>Onboard input – for the case that the SGE is parameterized at an onboard input. <bit> = input number = 01 ...04 <value> = value of the NCK-SGE = 0,1</p> <p>Interface identifier, drive input (%4): DBX<byte><bit>=<value> <byte> = byte number in the axial DB (22, 23, 32, 33) <bit> = bit number in the byte (0...7) <value> = value of the drive SGE (0,1) This alarm can be suppressed using the MD \$MN_SAFE_DIAGNOSIS_MASK, bit 0=0.</p>
Response	Alarm display
Remedy	Check re-connection for the safe input signals (NCK I/Os, PLC DB parameter supply).
Program continuation	Clear the alarm with the RESET key. Restart the part program.

27005 Axis %1 error for crosswise data comparison: Static actual value difference

Parameters	%1 = axis number
Explanation	<p>A difference in the actual values was detected using the crosswise data comparison between NCK and 611D monitoring channel. This difference is greater than the maximum tolerance defined in MD \$MA_SAFE_POS_TOL. This can be checked using the safe position actual values of the two monitoring channels displayed in the service screen.</p> <p>The alarm is only displayed, if monitoring with absolute reference (SE/SN) has been enabled for the specified axis and if the user agreement has been set. As soon as the user agreement is deleted or the actual difference between the two monitoring channels again drops below the maximum permissible difference, the alarm is cleared.</p>
Response	Alarm display
Remedy	<p>The user agreement must be deleted if the alarm is present as a steady-state alarm. When the control is then rebooted, the machine can be brought into the safe state again and operation resumed by a new referencing process and setting the user agreement. Prior to setting the user agreement, the actual position of the axis displayed in the "User enable" screen must be compared with the current machine position. This is absolutely necessary to ensure proper functioning of the safe limit positions (SE) and safe cams (SN).</p> <p>The user agreement can only be changed in key-actuated switch setting 3 or after entering a password.</p>
Program continuation	The alarm is no longer displayed when the alarm cause has been removed. No other operator actions are required.

27006 Axis %1 test ext. pulse cancellation running

Parameters	%1 = axis number
Explanation	The perfect functioning of the external pulse cancellation is presently being tested by setting the SGE "test stop external shutdown".
Response	Alarm display
Remedy	Alarm automatically disappears when the test is terminated by deleting the SGE "test stop external shutdown".
Program continuation	The alarm is no longer displayed when the alarm cause has been removed. No other operator actions are required.

8.2 Alarms for Sinumerik 840D

27007	Axis %1 acceptance test mode is active
Parameters	%1 = axis number
Explanation	An SI acceptance test has been started with the acceptance test Wizard at the operator interface. The acceptance test mode is activated for the NCK and drive for the duration of this acceptance test. In the acceptance test mode, SI power on alarms can be acknowledged with the reset key.
Response	Alarm display
Remedy	Acceptance test, e.g. de-select using the acceptance test Wizard or wait until it has been completed (the duration of the acceptance test can be parameterized using MD \$MA_SAFE_ACCEPTANCE_TST_TIMEOUT).
Program continuation	The alarm is no longer displayed when the alarm cause has been removed. No other operator actions are required.
27008	Axis %1 SW limit switch deactivated
Parameters	%1 = axis number
Explanation	An SI acceptance test safe limit position has been started with the acceptance test Wizard at the operator interface. For these acceptance tests, the single-channel SW limit switches are de-activated for the axis/spindle in order to ensure that the safe limit positions can be approached.
Response	Alarm display
Remedy	De-select the acceptance test, e.g. using the acceptance test Wizard or wait for the end of the test.
Program continuation	The alarm is no longer displayed when the alarm cause has been removed. No other operator actions are required.
27010	Axis %1 tolerance for safe operating stop exceeded
Parameters	%1 = axis number
Explanation	The axis has moved too far away from the reference position. It has moved farther away than permitted in MD \$MA_SAFE_STANDSTILL_TOL. The alarm can be re-configured in the MD \$MN_ALARM_REACTION_CHAN_NOREADY (channel not ready). Stop the axis with speed setpoint = 0 (STOP B). As soon as the speed actual value is less than that defined in the MD \$MA_SAFE_STANDSTILL_VELO_TOL, at the latest however, after the time in MD \$MA_SAFE_PULSE_DISABLE_DELAY expires, the pulses are cancelled (STOP A).

Response	Mode group not ready Channel not ready NC start inhibit in this channel Interface signals were set Alarm display NC stop for alarm Channel not ready
Remedy	Check the tolerance for the standstill monitoring: does the value match the precision and control dynamic performance of the axis? If not, increase the tolerance. If yes, check the machine for damage and repair it.
Program continuation	Power-down the control and power-up again

27011 Axis %1 safely-reduced speed exceeded

Parameters	%1 = axis number
Explanation	The axis has moved too quickly and faster than that specified in MD \$MA_SAFE_VELO_LIMIT. When SBH/SG is active and for a 1-encoder system, the speed, that corresponds to the encoder limit frequency saved in MD SAFE_ENC_FREQ_LIMIT was exceeded.
Response	NC start inhibit in this channel Interface signals are set Alarm display NC stop for alarm The axis is stopped with STOP A, C, D or E, depending on what has been configured in MD \$MA_SAFE_VELO_STOP_MODE or MD \$MA_SAFE_VELO_STOP_REACTION.
Remedy	If no obvious operator error has occurred: Check the value entered into the MDs, check the SGEs: Was the correct safely-reduced speed selected? If the MDs and SGEs are o.k., check the machine for any damage and rectify.
Program continuation	Clear the alarm with the RESET key. Restart the part program.

27012 Axis %1 safe limit position exceeded

Parameters	%1 = axis number
Explanation	The axis has passed the limit position entered in MD \$MA_SAFE_POS_LIMIT_PLUS or MD \$MA_SAFE_POS_LIMIT_MINUS. This axis is stopped with STOP C,D or E, according to the configuration in MD \$MA_SAFE_POS_STOP_MODE.
Response	NC start inhibit in this channel NC start inhibit in this channel Interface signals are set Alarm display NC stop for alarm

8.2 Alarms for Sinumerik 840D

Remedy	If no obvious operator error has occurred: Check the value entered in the machine data, check the SGEs: Was the correct one of 2 limit positions selected? If the MDs and SGEs are o.k., check the machine for any damage and repair.
Program continuation	Clear the alarm with the RESET key. Restart the part program. Withdraw the user agreement for this axis. Then press the RESET key. The program is aborted and the alarm reset. Move the axis – in the JOG mode – to the valid traversing range. After the NC program error has been eliminated and the position of this axis carefully checked, the user agreement can be re-issued and the program can be restarted.

27013**Axis %1 safe braking ramp exceeded**

Parameters	%1 = axis number
Explanation	After the initiation of STOP B or C, the speed exceeded the tolerance value entered in MD \$MA_SAFE_STOP_VELO_TOL. The pulses are locked by initiating a STOP A.
Response	Mode group not ready Channel not ready NC start inhibit in this channel Interface signals are set Alarm display NC stop for alarm
Remedy	Check the MD \$MA_SAFE_STOP_VELO_TOL. Check the braking characteristics of the drive involved.
Program continuation	Power-down the control and power-up again

27020**Axis %1 STOP E activated**

Parameters	%1 = axis number
Explanation	This alarm comes with Alarm 27011 "Safely-reduced speed exceeded" or 27012 "Safe limit position exceeded" (according to the configuration in MD \$MA_SAFE_VELO_STOP_MODE, \$MA_SAFE_VELO_STOP_REACTION or MD \$MA_SAFE_POS_STOP_MODE). A LIFTFAST-ASUB (sub-routine) is initiated and the safe operating stop (SBH) is internally activated after the time set in MD \$MA_SAFE_STOP_SWITCH_TIME_E has expired.
Response	NC start inhibit in this channel Alarm display NC stop for alarm Interface signals are set
Remedy	Remove the causes for "safely-reduced speed exceeded" and/or "safe limit position exceeded" alarms (refer to a description of the alarms).
Program continuation	Clear the alarm with the RESET key. Restart the part program.

27021	Axis %1 STOP D activated
Parameters	%1 = axis number
Explanation	This alarm comes with Alarms 27011 "Safely-reduced speed exceeded" or 27012 "Safe limit position exceeded" (according to the configuration in MD \$MA_SAFE_VELO_STOP_MODE, \$MA_SAFE_VELO_STOP_REACTION or \$MA_SAFE_POS_STOP_MODE). "Braking along the path" is initiated and the safe operating stop (SBH) is internally activated after the time set in MD \$MA_SAFE_STOP_SWITCH_TIME_D has expired.
Response	NC start inhibit in this channel Interface signals are set Alarm display NC stop for alarm
Remedy	Remove the causes for "safely-reduced speed exceeded" and/or "safe limit position exceeded" (refer to a description of the alarms).
Program continuation	Clear the alarm with the RESET key. Restart the part program.
27022	Axis %1 STOP C activated
Parameters	%1 = axis number
Explanation	This alarm comes with Alarms 27011 "Safely-reduced speed exceeded" or 27012 "Safe limit position exceeded" (according to the configuration in MD \$MA_SAFE_VELO_STOP_MODE, \$MA_SAFE_VELO_STOP_REACTION or \$MA_SAFE_POS_STOP_MODE). "Braking along the current limit" is initiated and the safe operating stop (SBH) is internally activated after the time, set in MD \$MA_SAFE_STOP_SWITCH_TIME_C has expired.
Response	NC start inhibit in this channel Interface signals are set Alarm display NC stop for alarm
Remedy	Remove the causes for "safely-reduced speed exceeded" and/or "safe limit position exceeded" (refer to a description of the alarms).
Program continuation	Clear the alarm with the RESET key. Restart the part program.

8.2 Alarms for Sinumerik 840D

27023	Axis %1: STOP B activated
Parameters	%1 = axis number
Explanation	This alarm comes with the Alarm 27010 "Tolerance for safe operating stop exceeded" or after the Alarm 27001 "STOP F initiated". The alarm can be re-configured in the MD ALARM_REACTION_CHAN_NOREADY (channel not ready). "Braking at the current limit" is initiated and the timer for changeover to STOP A is activated (refer to MD \$MA_SAFE_PULSE_DISABLE_DELAY).
Response	Mode group not ready Channel not ready NC start inhibit in this channel Interface signals are set Alarm display NC stop for alarm
Remedy	Remove the cause for "Tolerance for safe standstill exceeded" or for "STOP F initiated" (refer to the description of the alarms).
Program continuation	Power-down the control and power-up again
27024	Axis %1 STOP A activated
Parameters	%1 = axis number
Explanation	This alarm is output as a result of – Alarm 27011 "Safely-reduced speed exceeded" (for the appropriate configuring in \$MA_SAFE_VELO_STOP_MODE, \$MA_SAFE_VELO_STOP_REACTION), – Alarm 27013 "Safe braking ramp exceeded" – Alarm 27023 "Stop B initiated" – Unsuccessful test stop. The alarm can be re-configured in the MD ALARM_REACTION_CHAN_NOREADY (channel not ready).
Response	Mode group not ready Channel not ready NC start inhibit in this channel Interface signals are set Alarm display NC stop for alarm "Pulse cancellation" initiated.
Remedy	Remove the causes of – Alarm "safely-reduced speed exceeded", – Alarm "safe braking ramp exceeded", – Alarm "Stop B initiated" – Unsuccessful test stop (refer to the description of the alarms).
Program continuation	Power-down the control and power-up again

27030	Axis %1 function not supported on this 611D module
Parameters	%1 = axis number
Explanation	Safety Integrated can only be used with the 611D Performance control modules with 2 measuring circuits per drive and shutdown relay. An attempt has been made to activate a safety function although no such module is plugged in.
Response	Mode group not ready Channel not ready NC start inhibit in this channel Interface signals are set Alarm display NC stop for alarm
Remedy	Replace the module or switch–off safety functions in MD \$MA_SAFE_FUNCTION_ENABLE.
Program continuation	Power–down the control and power–up again
27031	Axis %1 limit value for safely–reduced speed %2 for ratio %3 too high (max. %4)
Parameters	%1 = axis number %2 = limit value index %3 = number of the ratio %4 = maximum speed
Explanation	All of the limit values in MD \$MA_SAFE_VELO_LIMIT must be set so that the limit frequency of the amplitude monitoring in the measuring circuit hardware is not exceeded. The limit value that does not comply with this condition, is specified here as second parameter (1 for SG1, 2 for SG2, etc.). The third parameter indicates the gear stage, e.g. 1 for gear stage 1, 2 for gear stage 2, etc. The fourth parameter indicates the maximum speed that can be entered to just maintain the limit frequency in safe operation. The alarm can be re–configured in the MD ALARM_REACTION_CHAN_NOREADY (channel not ready).
Response	Mode group not ready Channel not ready NC start inhibit in this channel Interface signals are set Alarm display NC stop for alarm "Pulse cancellation" initiated.
Remedy	Reduce the limit value in MD \$MA_SAFE_VELO_LIMIT[x], x = (2nd alarm parameter) – 1, or correct the setting of the gear factors.
Program continuation	Power–down the control and power–up again

27032	Axis %1 checksum error %2 safety-relevant monitoring functions. Acknowledgment and acceptance test required!
Parameters	%1 = axis number
Explanation	The relevant MDs \$MN_SAFE_..., \$MN_PROFISAFE_..., \$MA_SAFE ... are protected by a checksum. The alarm indicates that the current checksum is no longer the same as the reference checksum that has been saved, i.e. this means that an MD value has either been changed illegally or data is corrupted. The 2nd parameter specifies in which field entry of \$MA_SAFE_ACT_CHECKSUM the error was detected.
Response	Mode group not ready Channel not ready NC start inhibit in this channel Interface signals are set Alarm display NC stop for alarm
Remedy	Check MDs. Have the checksum re-calculated. Safety functions should be subject to a new acceptance test.
Program continuation	Power-down the control and power-up again
27033	Axis %1 parameterization of the MD %2[%3] not valid
Parameters	%1 = axis number %2 = machine data identifier %3 = machine data index
Explanation	The parameterization of machine data %2 is incorrect. An additional indication is the field index of the machine data. If the machine data is a single machine data, a zero is specified as array index. This alarm occurs in the following contexts: <ul style="list-style-type: none"> – 1. The conversion of the specified MD into the internal computation format resulted in an overflow. – 2. The values entered in MD \$MA_SAFE_POS_LIMIT_PLUS and \$MA_SAFE_POS_LIMIT_MINUS have been interchanged. The upper limit is less than or equal to the lower limit. – 3. For an axis with safety functions the setpoint/actual value assignment in MD \$MA_SAFE_ENC_SEGMENT_NR, MD \$MA_CTRLOUT_SEGMENT_NR was not made for the drive bus. No module number was specified for a setpoint/actual value channel assignment in MD \$MA_CTRLOUT_MODULE_NR, MD \$MA_SAFE_ENC_MODULE_NR. – 4. The number of drives has changed. When reading back the standstill position and the associated drive number, a difference was identified to the actual drive configuration.

- 5.
A safety function was enabled in MD \$MA_SAFE_FUNCTION_ENABLE without the safety functions SBH/SG having been enabled.
- 6.
Error when parameterizing the input/output assignments for the SGEs/SGAs.
- 7.
A zero was entered in MD \$MA_SAFE_ENC_GRID_POINT_DIST.
- 8.
A zero was entered into MD \$MA_SAFE_ENC_RESOL.
- 9.
Various settings were made in MD \$MA_IS_ROT_AX and MD \$MA_SAFE_IS_ROT_AX.
- 10.
A non-existent measuring circuit was parameterized in MD \$MA_SAFE_ENC_INPUT_NR.
- 11.
The number of a drive was entered into MD \$MA_SAFE_ENC_MODULE_NR that is either non-existent or is detected as being inactive. For an inactive drive, MD \$MA_SAFE_ENC_TYPE was not reset to 0.
- 12.
An encoder type was parameterized in MD \$MA_SAFE_ENC_TYPE that does not correspond to the actual type being used.
- 13.
An incorrect encoder type (\$MA_SAFE_ENC_TYPE = 0, 2, 3 or 5) for an active drive was entered in MD \$MA_SAFE_ENC_TYPE.
- 14.
When parameterizing the motor encoder in MD \$MA_SAFE_ENC_INPUT_NR, the measuring circuit for the 2nd measuring system is also used in order to secure the two-channel functionality.
The 2nd measuring circuit of this drive module was also parameterized in the data of another axis so that there is a double assignment. The 2nd measuring circuit connection – for this parameterization – cannot be used for the actual value sensing.
- 15.
For a linear axis, a value of greater than 10 mm was entered into MD \$MA_SAFE_POS_TOL.
- 16.
For a linear axis, a value of greater than 1 mm was entered into MD \$MA_SAFE_REFP_POS_TOL.
- 17.
The limit values for the "n<n_x" monitoring function, calculated from MD \$MA_SAFE_VELO_X and MD \$MA_SAFE_POS_TOL are the same magnitude.

8.2 Alarms for Sinumerik 840D

– 18.

One of the activated cam positions is outside the actual value modulo range.

– 19.

The parameterized cam modulo range MD \$MA_SAFE_MODULO_RANGE is not an integral multiple of 360 degrees.

– 20.

The parameterized cam modulo range MD \$MA_SAFE_MODULO_RANGE and the modulo range in MD \$MA_MODULO_RANGE cannot be divided by one another to result in an integral number.

– 21.

The function "actual value synchronization 2–encoder system" (slip) is selected for a single–encoder system or a function with absolute reference (SE/SN) is simultaneously selected .

– 22.

The Alarms 27000/300950 should be suppressed when parking (MD \$MA_SAFE_PARK_ALARM_SUPPRESS!=0). In this case, the SGA "axis safely referenced" must be parameterized using the MD \$MA_SAFE_REFP_STATUS_OUTPUT.

– 23.

An axial SGE/SGA was parameterized at the SPL interface (segment number = 4) and the function enable for the external stops is missing (MD \$MA_SAFE_FUNCTION_ENABLE, bit 6).

– 24.

An axial SGE/SGA was parameterized at the SPL interface (segment number = 4) and the SGE "Deselect ext. Stop A" (assignment via MD \$MA_SAFE_EXT_STOP_INPUT[0]) was parameterized inverted (bit 31 = 1) or the SGE "Deselect ext. Stop A" was not parameterized at the SPL interface \$A_OUTSI.

– 25.

For the parameterized incremental encoder, the function "save actual value for incremental encoder" is selected using MD \$MA_ENC_REFP_STATE and a monitoring function with absolute reference (SE/SN) is selected using MD \$MA_SAFE_FUNCTION_ENABLE. This combination of functions is not permitted.

– 26.

For a linear axis, a value greater than 1000 mm/min was entered into MD \$MA_SAFE_STANDSTILL_VELO_TOL.

– 27.

For a linear axis, a value greater than 20000 mm/min was entered into MD \$MA_SAFE_STOP_VELO_TOL.

– 28.

For a linear axis, a value greater than 1000 mm/min was entered into MD \$MA_SAFE_VELO_X.

– 29.

For a linear axis, a value greater than 1000 mm/min was entered into MD \$MA_SAFE_SLIP_VELO_TOL.

– 30.

A value greater than the maximum selectable encoder limit frequency for safe operation of a single–encoder system was set in MD \$MA_SAFE_ENC_FREQ_LIMIT.

– 31.

A value greater than 300 kHz for a Performance 1 or Standard 2 control module was set in MD \$MA_SAFE_ENC_FREQ_LIMIT.

– 32.

MD \$MA_SAFE_EXT_PULSE_ENAB_OUTPUT was not parameterized or was not correctly parameterized. This MD must be parameterized if bit 30 in MD \$MA_SAFE_PULSE_ENABLE_OUTPUT is set to 1 – i.e. internal pulse cancellation is used.

– 33.

MD \$MN_SAFE_SPL_STOP_MODE was parameterized to a value of 4 (Stop E) without having enabled the external Stop E in all axes with SI function enable signals (MD \$MA_SAFE_FUNCTION_ENABLE not equal to 0).

– 34.

The mechanical brake system test was enabled in MD \$MA_FIXED_STOP_MODE (bit 1 = 1), without safe operation having been enabled for this axis in MD \$MA_SAFE_FUNCTION_ENABLE. The mechanical brake system test is only permissible in this axis with safety functions.

– 35.

An illegal value was parameterized in MD \$MA_SAFE_VELO_STOP_MODE or MD \$MA_SAFE_VELO_STOP_REACTION.

– 36.

The cam synchronization is activated in MD \$MA_SAFE_FUNCTION_ENABLE using bit 7 without the cam having been enabled via bit 8 ...bit 15 or via \$MA_SAFE_CAM_ENABLE.

–37.

The cam is enabled both via \$MA_SAFE_FUNCTION_ENABLE as well as also via \$MA_SAFE_CAM_ENABLE

–38.

In MD \$MA_SAFE_DRIVE_PS_ADDRESS an invalid value was parameterized or the same address was assigned for several axes.

–39.

It was not possible to internally pre–assign MD \$MA_SAFE_ENC_PULSE_SHIFT from the drive parameterization as the values must have been entered outside the permissible range. Adapt the encoder parameterization in the drive.

–40.

MD \$MA_SAFE_VELO_OVR_FACTOR was parameterized with decimal places.

8.2 Alarms for Sinumerik 840D

Response	Mode group not ready Channel not ready NC start inhibit in this channel Interface signals are set Alarm display NC stop for alarm
Remedy	Check and modify the MD named in the alarm text. Have the checksum re-calculated. Safety functions should be subject to a new acceptance test.
Program continuation	Power-down the control and power-up again

27034**Parameterization of MD %1 invalid**

Parameters	%1 = machine data identifier
Explanation	The parameterization of machine data %1 is incorrect. This alarm occurs in conjunction with the following: – An invalid value was set for MD \$MN_SAFE_ALARM_SUPPRESS_LEVEL.
Response	Mode group not ready Channel not ready NC start inhibit in this channel Interface signals are set Alarm display NC stop for alarm
Remedy	Check and correct the specified machine data.
Program continuation	Power-down the control and power-up again

27090**Error in crosswise data comparison NCK-PLC %1 [%2], NCK: %3; %4<ALSI>**

Parameters	%1 = name of the system variable in which the error was detected %2 = supplementary info, system variables – field index %3 = supplementary information, comparison value, NCK %4 = supplementary information, crosswise data comparison – field index
Explanation	For the cyclic crosswise data comparison between NCK and PLC, differences have occurred in the data being compared. Parameter %1 specifies the incorrect system variable (\$A_INSI, \$A_OUTSI, \$A_INSE, \$A_OUTSE or \$A_MARKERSI) with field index %2. Special cases: – Display "Error for crosswise data comparison NCK-PLC, \$MN_PREVENT_SYNACT_LOCK[0], ..." means that the SPL commissioning status is set differently in the NCK and PLC. – Display "Error for crosswise data comparison NCK-PLC, \$MN_SPL_STOP_MODE[0], ..." means that the SPL stop response (Stop D or E) is set differently in the NCK and PLC. – Display "Error for crosswise data comparison NCK-PLC, TIMEOUT[0], NCK: 0" means that there is a critical communications

error between the NCK and PLC and no crosswise data comparison can be carried-out.

For crosswise data comparison errors at the system variables \$A_INSE, the system variable involved is specified in alarm parameter %1 and the hardware assignment parameterized in MD

\$MN_SAFE_IN_HW_ASSIGN[0...7] is displayed, so that the hardware connection involved can be directly seen from the data in the alarm line.

Example: Error for the crosswise data comparison, NCK-PLC, DMP 04.03 bit 01=\$A_INSE[2], NCK: 1;

The information in the example (04.03) corresponds to the entries made in the machine data \$MN_SAFE_IN_HW_ASSIGN[0...7] about the specified system variables.

They specify:

DMP 04.xx The drive number of the terminal block involved (value range = 01...21)

DMP xx.03 Module number of the input module (value range = 01...08)

The specified numbers are in the hexadecimal notation the same as in MD \$MN_SAFE_IN_HW_ASSIGN[0...7].

The bit number is specified starting just the same as the numbering of the inputs on the DMP modules with the value 0 (value range = 00...15)

When assigning the SPL inputs to the NC onboard inputs, the expanded alarm text looks like this:

Error for the crosswise data comparison, NCK-PLC, NC-Onboard-In 01=\$A:INSE[1], NCK: 1; 2

Using parameter %4, a specific alarm message can be configured on the HMI for each of the listed system variables:

%4 = 0: Error SPL commissioning status

(\$MN_PREVENT_SYN-ACT_LOCK[0,1] – DB18.DBX36.0) or different stop response

\$MN_SAFE_SPL_STOP_MODE – DB18.DBX36.1)

%4 = 1... 64: Error in system variables \$A_INSE[1...64]

%4 = 65...128: Error in system variables \$A_OUTSE[1...64]

%4 = 129...192: Error in system variables \$A_INSI[1...64]

%4 = 193...256: Error in system variables \$A_OUTSI[1...64]

%4 = 257...320: Error in system variables \$A_MARKERSI[1...64]

In order to parameterize Alarm 27090, file ALSI_xx.com must be incorporated in the data management and communicated to the HMI via MBDDE.INI in Section [IndexTextFiles] ALNX=f:\dh\mb.dir\alsi_. The machinery construction OEM can re-define this file in order to incorporate sensible supplementary texts in the alarm for his particular machine/system. If the file is to be re-defined, the new file to be created must be made known to the system via MBDDE.INI.

The display of Alarm 27090 can be influenced using the MD

\$MN_SAFE_ALARM_SUPPRESS_LEVEL: MD

\$MN_SAFE_ALARM_SUPPRESS_LEVEL = 2 : Alarm 27090 is only displayed for the first data difference found.

8.2 Alarms for Sinumerik 840D

Response	Alarm display A STOP D/E is initiated (this can be set using MD \$MN_SPL_STOP_MODE) on all of the axes with safety functionality if the SPL commissioning phase (MD \$MN_PREVENT_SYNACT_LOCK[0,1] not equal to 0) has been completed.
Remedy	Analyze the displayed value and evaluate DB18: SPL_DELTA on the PLC side. Find the difference between the monitoring channels. Possible causes: <ul style="list-style-type: none"> – Incorrect wiring – Incorrect SPL – The axial SGEs have been incorrectly assigned to the internal interface \$A_OUTSI – The axial SGAs have been incorrectly assigned to the internal interface \$A_INSI – The SPL–SGEs have been incorrectly assigned to the external interface \$A_INSE – The SPL–SGAs have been incorrectly assigned to the external interface \$A_OUTSE – Different SPL commissioning status has been set in the NCK and PLC – Different SPL stop response has been set in the NCK and PLC
Program continuation	Clear the alarm with the RESET key. Restart the part program.
27091	
Parameters	Error in crosswise data comparison, NCK–PLC, STOP of %1 %1 = supplementary information about the monitoring channel that has initiated the stop
Explanation	The monitoring channel specified in %1 (NCK or PLC) has triggered a STOP D or E (depending on the parameterization in MD \$MN_SAFE_SPL_STOP_MODE). Alarm 27090 provides additional information about the reason for the Stop D/E.
Response	Alarm display A STOP D/E is initiated (this can be set using MD \$MN_SPL_STOP_MODE) on all of the axes with safety functionality if the SPL commissioning phase (MD \$MN_PREVENT_SYNACT_LOCK[0,1] not equal to 0) has been completed.
Remedy	Evaluate the alarm parameters of Alarm 27090 and correct the SPL, or check the I/O modules/wiring or the internal SPL interfaces to the safety monitoring channels in the NCK and 611D drive.
Program continuation	Clear the alarm with the RESET key. Restart the part program.

27092	Communications interrupted for crosswise data comparison NCK–PLC, error detected by %1
Parameters	%1 = supplementary information about the detecting monitoring channel
Explanation	The delay timer stage (1 s) for the communication monitoring has been exceeded in the monitoring channel specified in %1 (NCK or PLC). The other monitoring channel did not send new data within this time.
Response	Alarm display A STOP D/E is initiated (this can be set using MD \$MN_SPL_STOP_MODE) on all of the axes with safety functionality if the SPL commissioning phase (MD \$MN_PREVENT_SYNACT_LOCK[0,1] not equal to 0) has been completed. A timer stage of 5 sec is started – after it has expired – the external NCK–SPL outputs are deleted (cleared). – the PLC goes to stop.
Remedy	Do not start the SPL anymore. Check the system components (PLC must have the correct version of FB15 and have DB18).
Program continuation	Power–down the control and power–up again

8.2 Alarms for Sinumerik 840D

27093	Checksum error NCK–SPL, %1, %2, %3
Parameters	%1 = supplementary information about the type of error %2 = supplementary information about the reference size %3 = supplementary information about the current size
Explanation	The checksum error in the NCK SPL. The file /_N_CST_DIR/_N_SAFE_SPF was subsequently modified. The safe programmable logic (SPL) in the NCK may be corrupted. Parameter %1 provides further information about the type of change: %1 = FILE_LENGTH: The file length has changed. %1 = FILE_CONTENT: The file contents have changed. %2 specifies the reference variable (file length, checksum of file contents), %3 specifies the actual variable which is calculated cyclically.
Response	Alarm display
Remedy	Check the file and when the file was last changed. Reload the original file and start the monitoring system again with a power on.
Program continuation	Power–down the control and power–up again
27094	Write access to system variable %1 only allowed from NCK–SPL
Parameters	%1 = name of the safety system variable involved
Explanation	It is only possible to write access one of the safety system variables from the part program /_N_CST_DIR/_N_SAFE_SPF. If this error occurs, an instruction from another part program was detected.
Response	Alarm display
Remedy	Check the part program used to write access safety system variables.
Program continuation	Clear the alarm with the RESET key. Restart the part program.
27095	%1 SPL protection not activated
Parameters	%1 = name of the component for which the protection is not activated (NCK or PLC)
Explanation	The protective mechanisms for the SPL have not been activated. The commissioning phase of the SPL has not yet been completed. For an error in the crosswise data comparison between NCK and PLC, a stop response (Stop D or E) is not initiated.
Response	Alarm display
Remedy	Remedy for NCK: Activate the protective mechanisms by writing to MD \$MN_PREVENT_SYNACT_LOCK [0,1]. The number range of the synchronous action IDs used in the SPL must be entered into these MDs. Remedy for the PLC: Activate the protective mechanisms by setting the appropriate data bit in DB18.
Program continuation	Clear the alarm with the RESET key. Restart the part program.

27096	SPL start not allowed
Explanation	To start the SPL in the protected state (\$MN_PREVENT_SYNACT_LOCK[0,1] not equal to 0), at least one axis must have safety integrated functionality activated (via MD \$MA_SAFE_FUNCTION_ENABLE) beforehand. Without this functionality it is only possible to operate the SPL in the commissioning state.
Response	Mode group not ready Channel not ready NC start inhibit in this channel NC stop for alarm Alarm display Interface signals are set
Remedy	Commission the axial safety integrated functionality or cancel the SPL protection using MD \$MN_PREVENT_SYNACT_LOCK[0,1].
Program continuation	Power-down the control and power-up again
27100	At least one axis is not safely referenced
Explanation	<p>There are two reasons for this alarm:</p> <ul style="list-style-type: none"> – the machine position of at least one of the axes monitored with SI has not been acknowledged by the user or – the machine position of at least one of the axes monitored with SI has still not been verified by subsequent referencing <p>Even if the axis is already referenced there is no acknowledgment that referencing has supplied the correct result. For example, incorrect results can occur if the axis was moved after the control was powered-down – with the result that the standstill position saved prior to powering-down is no longer correct. To ensure that this does not happen, the user must acknowledge the displayed actual position after the first referencing process.</p> <p>When the user agreement has been set for the first time, the axis must be subsequently referenced each time that the control is run-up (when absolute encoders are used, this subsequent referencing is automatically executed). This procedure is carried-out to verify the standstill position saved prior to powering-down the control.</p> <p>The alarm display can be set in MD \$MN_SAFE_ALARM_SUPPRESS_LEVEL (MD<3) in such a way that incorrect referencing is displayed separately for each axis.</p>

8.2 Alarms for Sinumerik 840D

Response	Alarm display The SGA "axis safely referenced" is not set. SE is disabled if the safe actual position has not yet been acknowledged by the user agreement. If the user agreement is set, SE remains active. The safe cams are calculated and output, but their significance is limited because referencing has not been acknowledged.
Remedy	Move all SI axes to known positions and change to "Referencing" mode. Check the positions on the machine displayed in the user agreement screen and set the "User agreement" using the selection/toggle key. If the user agreement has already been set for the axis, then re-reference the axes. It is only possible to change the user agreement in the key-operated switch position 3 or after entering a password.
Program continuation	The alarm is no longer displayed when the alarm cause has been removed. No other operator actions are required.

27101 Axis %1, difference in function safe operating stop, NCK: %2, drive: %3

Parameters	%1 = axis number %2 = monitoring status, safe operating stop %3 = monitoring status, safe operating stop
Explanation	In the crosswise data comparison of result list 1 between the NCK and drive monitoring channels, a difference was detected in the state of the safe operating stop monitoring. Safe operating stop: Bit 0,1 in result list 1 Monitoring state (%2, %3): <ul style="list-style-type: none"> – OFF = monitoring inactive in this monitoring channel – OK = monitoring active in this monitoring channel, limit values not violated – L+ = monitoring active in this monitoring channel, upper limit value violated – L- = monitoring active in this monitoring channel, lower limit value violated
Response	Alarm display If a safety monitoring function was active (SBH, SG, SE, SN), then a STOP B was also automatically initiated. It is necessary to power-down the control and power it up again (power on).
Remedy	Check that the safe inputs in both monitoring channels have switched into the same state within the permissible time tolerance. For further diagnostics, refer to the drive machine data 1391, 1392 and the servo-trace signal "result list 1 NCK" and "result list 1 drive".
Program continuation	Clear the alarm with the RESET key. Restart the part program.

27102	Axis %1, difference in function safely-reduced speed %2, NCK: %3, drive: %4
Parameters	<p>%1 = axis number %2 = SG stage for which the difference was detected %3 = monitoring status, safely-reduced speed %4 = monitoring status, safely-reduced speed</p>
Explanation	<p>In the crosswise data comparison of result list 1 between the NCK and drive monitoring channels, a difference in the monitoring state of the safely-reduced speed monitoring was detected.</p> <ul style="list-style-type: none"> - Safely-reduced speed 1: Bits 6, 7 in result list 1 - Safely-reduced speed 2: Bits 8, 9 in result list 1 - Safely-reduced speed 3: Bits 10, 11 in result list 1 - Safely-reduced speed 4: Bits 12, 13 in result list 1 <p>Monitoring state (%3, %4):</p> <ul style="list-style-type: none"> - OFF = monitoring inactive in this monitoring channel - OK = monitoring active in this monitoring channel, limit values not violated - L+ = monitoring active in this monitoring channel, upper limit value violated - L- = monitoring active in this monitoring channel, lower limit value violated
Response	<p>Alarm display</p> <p>If a safety monitoring function was active (SBH, SG, SE, SN), then a STOP B was also automatically initiated. It is necessary to power-down the control and power it up again (power on).</p>
Remedy	<p>Check that the safe inputs in both monitoring channels have switched into the same state within the permissible time tolerance.</p> <p>For further diagnostics, refer to the drive machine data 1391, 1392 and the servo-trace signal "result list 1 NCK" and "result list 1 drive".</p>
Program continuation	<p>Clear the alarm with the RESET key. Restart the part program.</p>

27103	Axis %1, difference in function safe limit position %2, NCK: %3, drive: %4
Parameters	<p>%1 = axis number %2 = number of the SE limit %3 = monitoring status, safe limit position %4 = monitoring status, safe limit position</p>
Explanation	<p>In the crosswise data comparison of result list 1 between the NCK and drive monitoring channels, a difference was detected in the monitoring state of the safe limit position monitoring.</p> <ul style="list-style-type: none"> – Safe limit position 1: Bits 2, 3 in result list 1 – Safe limit position 2: Bits 4, 5 in result list 1 <p>Monitoring state (%3, %4):</p> <ul style="list-style-type: none"> – OFF = monitoring inactive in this monitoring channel – OK = monitoring active in this monitoring channel, limit values not violated – L+ = monitoring active in this monitoring channel, upper limit value violated – L– = monitoring active in this monitoring channel, lower limit value violated
Response	<p>Alarm display</p> <p>If a safety monitoring function was active (SBH, SG, SE, SN), then a STOP B was also automatically initiated. It is then necessary to power-down/power-up the control (power on).</p>
Remedy	<p>Check that the safe inputs in both monitoring channels have switched into the same state within the permissible time tolerance.</p> <p>For further diagnostics, refer to the drive machine data 1391 and 1392 and the servo-trace signal "result list 1 NCK" and "result list 1 drive".</p>
Program continuation	<p>Clear the alarm with the RESET key. Restart the part program.</p>

27104	Axis %1, difference in function safe cam plus %2, NCK: %3, drive: %4
Parameters	<p>%1 = axis number %2 = number of the cam %3 = monitoring status, safe cam plus %4 = monitoring status, safe cam plus</p>
Explanation	<p>During the crosswise comparison of result list 2 between the NCK and drive monitoring channels, a difference was detected in the monitoring state of the safe cam plus monitoring.</p> <ul style="list-style-type: none"> – Safe cam 1+: Bits 0, 1 in result list 2 – Safe cam 2+: Bits 4, 5 in result list 2 – Safe cam 3+: Bits 8, 9 in result list 2 – Safe cam 4+: Bits 12, 13 in result list 2 <p>Monitoring state (%3, %4):</p> <ul style="list-style-type: none"> – OFF = monitoring inactive in this monitoring channel – OK = monitoring active in this monitoring channel, limit values not violated – L+ = monitoring active in this monitoring channel, upper limit value violated – L– = monitoring active in this monitoring channel, lower limit value violated
Response	Alarm display
Remedy	<p>If a safety monitoring function was active (SBH, SG, SE, SN), then a STOP B was also automatically initiated. It is necessary to power-down the control and power it up again (power on). Check that the safe actual values in both monitoring channels match. For further diagnostics, refer to the drive machine data 1393, 1394 and the servo-trace signal "result list 2 NCK" and "result list 2 drive".</p>
Program continuation	Clear the alarm with the RESET key. Restart the part program.

27105	Axis %1, difference in function safe cam minus %2, NCK: %3, drive: %4
Parameters	<p>%1 = axis number %2 = number of the cam %3 = monitoring status, safe cam minus %4 = monitoring status, safe cams minus</p>
Explanation	<p>In the crosswise comparison of result list 2 between the NCK and drive monitoring channels, a difference was detected in the monitoring state of the safe cam minus monitoring.</p> <ul style="list-style-type: none"> – Safe cam 1–: Bits 2, 3 in result list 2 – Safe cam 2–: Bits 6, 7 in result list 2 – Safe cam 3–: Bits 10, 11 in result list 2 – Safe cam 4–: Bits 14, 15 in result list 2 <p>Monitoring state (%3, %4):</p> <ul style="list-style-type: none"> – OFF = monitoring inactive in this monitoring channel – OK = monitoring active in this monitoring channel, limit values not violated – L+ = monitoring active in this monitoring channel, upper limit value violated – L– = monitoring active in this monitoring channel, lower limit value violated
Response	<p>Alarm display</p> <p>If a safety monitoring function was active (SBH, SG, SE, SN), then a STOP B was also automatically initiated. It is necessary to power-down the control and power it up again (power on).</p>
Remedy	<p>Check that the safe actual values in both monitoring channels match. For further diagnostics, refer to the drive machine data 1393, 1394 and the servo-trace signal "result list 2 NCK" and "result list 2 drive".</p>
Program continuation	<p>Clear the alarm with the RESET key. Restart the part program.</p>

27106	Axis %1, difference in function safely-reduced speed nx, NCK: %2, drive: %3
Parameters	%1 = axis number %2 = monitoring status, safely-reduced speed nx %3 = monitoring status, safely-reduced speed nx
Explanation	In the crosswise data comparison of result list 2 between the NCK and drive monitoring channels, a difference was detected in the monitoring state of the safely-reduced speed nx monitoring. <ul style="list-style-type: none"> – Safely-reduced speed nx+: Bits 16, 17 in result list 2 – Safely-reduced speed nx-: Bits 18, 19 in result list 2 Monitoring state (%2, %3): <ul style="list-style-type: none"> – OFF = monitoring inactive in this monitoring channel – OK = monitoring active in this monitoring channel, limit values not violated – L+ = monitoring active in this monitoring channel, upper limit value violated – L- = monitoring active in this monitoring channel, lower limit value violated
Response	Alarm display If a safety monitoring function was active (SBH, SG, SE, SN), then a STOP B was also automatically initiated. It is necessary to power-down the control and power it up again (power on).
Remedy	Check that the safe actual values in both monitoring channels match. For further diagnostics, refer to the drive machine data 1393, 1394 and the servo-trace signal "result list 2 NCK" and "result list 2 drive".
Program continuation	Clear the alarm with the RESET key. Restart the part program.
27107	Axis %1, difference with cam modulo monitoring function, NCK: %2, drive: %3
Parameters	%1 = axis number %2 = monitoring status, safe cam modulo range %3 = monitoring status, safe cam modulo range
Explanation	In the crosswise comparison of result list 2 between the NCK and drive monitoring channels, a difference was detected in the monitoring state of the cam modulo area monitoring. Safe cam modulo range: Bits 20, 21 in result list 2 Monitoring state (%2, %3): <ul style="list-style-type: none"> – OFF = monitoring inactive in this monitoring channel – OK = monitoring active in this monitoring channel, limit values not violated – L+ = monitoring active in this monitoring channel, upper limit value violated

8.2 Alarms for Sinumerik 840D

	– L– = monitoring active in this monitoring channel, lower limit value violated
Response	Alarm display If a safety monitoring function was active (SBH, SG, SE, SN), then a STOP B was also automatically initiated. It is necessary to power-down the control and power it up again (power on).
Remedy	Check that the safe actual values in both monitoring channels match. For further diagnostics, refer to the drive machine data 1393, 1394 and the servo-trace signal "result list 2 NCK" and "result list 2 drive".
Program continuation	Clear the alarm with the RESET key. Restart the part program.
27124 Stop A initiated for at least 1 axis	
Explanation	This alarm only indicates that Stop A has been triggered in at least one axis and power on is required to acknowledge the alarm. The alarm is output if the alarm priority function was activated in MD \$MN_SAFE_ALARM_SUPPRESS_LEVEL.
Response	Alarm display Interface signals are set "Pulse cancellation" is initiated for the axis involved.
Remedy	Locate the cause of the error by evaluating additional alarm messages
Program continuation	Power-down the control and power-up again
27200 PROFIsafe: Cycle time %1 [ms] is too long	
Parameters	%1 = parameterized cycle time
Explanation	The PROFIsafe communication cycle time resulting from MD \$MN_PROFISAFE_IPO_TIME_RATIO and \$MN_IPO_CYCLE_TIME exceeds the permissible limit value (25 ms).
Response	Mode group not ready Channel not ready NC start inhibit in this channel Interface signals are set Alarm display NC stop for alarm
Remedy	Correct the cycle time using MD \$MN_PROFISAFE_IPO_TIME_RATIO or reduce the IPO clock cycle.
Program continuation	Power-down the control and power-up again

27201	PROFIsafe: MD %1[%2]: Bus segment %3 error
Parameters	%1 = MD name %2 = MD field index %3 = parameterized bus segment
Explanation	An incorrect bus segment was entered in the specified machine data. The value must be 5.
Response	Mode group not ready Channel not ready NC start inhibit in this channel Interface signals are set Alarm display NC stop for alarm
Remedy	Correct the MD.
Program continuation	Power-down the control and power-up again
27202	PROFIsafe: MD %1[%2]: Address %3 error
Parameters	%1 = MD name %2 = MD field index %3 = parameterized PROFIsafe address
Explanation	An incorrect PROFIsafe address was entered in the specified machine data. The value must be greater than 0.
Response	Mode group not ready Channel not ready NC start inhibit in this channel Interface signals are set Alarm display NC stop for alarm
Remedy	Correct the MD.
Program continuation	Power-down the control and power-up again
27203	PROFIsafe: MD %1[%2]: Incorrect SPL assignment
Parameters	%1 = MD name %2 = MD field index
Explanation	The parameterization in the specified MD for the connection between the SPL interface and a PROFIsafe module is incorrect. The reasons for this are as follows: <ul style="list-style-type: none"> – Bit limits interchanged (upper bit value < lower bit value) – Bit values greater than in the definition of the SPL interface (bit value > 64) – Number of bits too high for this PROFIsafe module (upper bit value – lower bit value + 1 > 8) – No SPL assignment was parameterized (both bit values are equal to zero) – Incorrect SPL assignment (bit value equal to zero)

8.2 Alarms for Sinumerik 840D

Response	Mode group not ready Channel not ready NC start inhibit in this channel Interface signals are set Alarm display NC stop for alarm
Remedy	Correct the MD.
Program continuation	Power-down the control and power-up again
27204	PROFIsafe: Double assignment MD %1[%2] – MD %3[%4]
Parameters	%1 = MD name 1 %2 = MD field index for MD name 1 %3 = MD name 2 %4 = MD field index for MD name 2
Explanation	A double assignment has been illegally parameterized in the specified machine data. A_INSE are parameterized on the DMP as well as PROFIsafe modules. MDs involved: – MD \$MN_SAFE_IN_HW_ASSIGN – MD \$MN_PROFISAFE_IN_ASSIGN \$A_INSE are parameterized on several PROFIsafe modules. MDs involved: – MD \$MN_PROFISAFE_IN_ASSIGN
Response	Mode group not ready Channel not ready NC start inhibit in this channel Interface signals are set Alarm display NC stop for alarm
Remedy	Correct the MD.
Program continuation	Power-down the control and power-up again
27205	PROFIsafe: Number of signals in MD %1[%2] – MD %3[%4]
Parameters	%1 MD name 1 %2 MD field index to the MD name 1 %3 MD name 2 %4 MD field index to the MD name 2
Explanation	The parameterized number of signals used must be the same in both machine data.

Response	Mode group not ready Channel not ready NC start inhibit in this channel Interface signals are set Alarm display NC stop for alarm
Remedy	Correct the MD.
Program continuation	Power-down the control and power-up again
27206	PROFIsafe: MD %1[%2] max. bit index %3 exceeded
Parameters	%1 MD name %2 MD field index to the MD name %3 max. bit index
Explanation	Data parameterized in the specified machine data lie outside the F net (useful) data area of the F module.
Response	Mode group not ready Channel not ready NC start inhibit in this channel Interface signals are set Alarm display NC stop for alarm
Remedy	Correct the MD.
Program continuation	Power-down the control and power-up again
27207	PROFIsafe: MD %1[%2] max. sub-slot number: %3 exceeded
Parameters	%1 MD name %2 MD field index to the MD name %3 max. number of sub-slots
Explanation	The sub-slot parameterized in the specified machine data exceeds the max. permissible number of sub slots per PROFIsafe module.
Response	Mode group not ready Channel not ready NC start inhibit in this channel Interface signals are set Alarm display NC stop for alarm
Remedy	Reduce the number of sub-slots by changing the F net (useful) data distribution of the PROFIsafe module.
Program continuation	Power-down the control and power-up again

8.2 Alarms for Sinumerik 840D

27220	PROFIsafe: Number of NCK F modules (%1) <> number of S7-F modules (%2)
Parameters	%1 = number of parameterized NCK-F modules %2 = number of parameterized S7-F modules
Explanation	The number of F modules parameterized using the NCK machine data \$MN_PROFISAFE_IN/OUT_ADDRESS is <ul style="list-style-type: none"> – greater than the number of PROFIBUS slaves in the configured S7 PROFIBUS – less than the number of F modules in the configured S7 PROFIBUS – greater than the number of F modules in the configured S7 PROFIBUS
Response	Mode group not ready Channel not ready NC start inhibit in this channel Interface signals are set Alarm display NC stop for alarm
Remedy	Check the F parameterization in the MD \$MN_PROFISAFE_IN/OUT_ADDRESS. Check the F configuration in the S7 PROFIBUS configuration. Check the parameterized PROFIsafe master address in MD \$MN_PROFISAFE_MASTER_ADDRESS and S7 PROFIBUS configuration.
Program continuation	Power-down the control and power-up again
27221	PROFIsafe: NCK F module MD %1[%2] unknown
Parameters	%1 = MD name %2 = MD field index
Explanation	The F module parameterized in the specified machine data is unknown under this PROFIsafe address in the S7 PROFIBUS configuration.
Response	Mode group not ready Channel not ready NC start inhibit in this channel Interface signals are set Alarm display NC stop for alarm
Remedy	Check the PROFIsafe addresses in the NCK-MD and S7-PROFIBUS configuration
Program continuation	Power-down the control and power-up again

27222	PROFIsafe: S7 F module PROFIsafe address %1 unknown
Parameters	%1 = PROFIsafe address
Explanation	The F module with the specified PROFIsafe address has not been parameterized as an F module in the NCK MD
Response	Mode group not ready Channel not ready NC start inhibit in this channel Interface signals are set Alarm display NC stop for alarm
Remedy	Check the S7 PROFIBUS configuration. Register the module in the NCK MD
Program continuation	Power-down the control and power-up again
27223	PROFIsafe: NCK F module MD %1[%2] is not a %3 module
Parameters	%1 = MD name %2 = MD field index %3 = module type
Explanation	The F module parameterized in the specified NCK MD has not been designated as an appropriate input/output module in the S7 PROFIBUS configuration. – %3 = INPUT: NCK F parameterization expects an INPUT module – %3 = OUTPUT: NCK F parameterization expects an OUTPUT module – %3 = IN/OUT: NCK F parameterization expects an INPUT/OUTPUT module
Response	Mode group not ready Channel not ready NC start inhibit in this channel Interface signals are set Alarm display NC stop for alarm
Remedy	Check the module in the S7 PROFIBUS configuration
Program continuation	Power-down the control and power-up again

27224	PROFIsafe: F module MD %1[%2] – MD %3[%4]: Double assignment of thePROFIsafe address
Parameters	%1 = MD name 1 %2 = MD field index 1 %3 = MD name 2 %4 = MD field index 2
Explanation	In the NCK MD or in the S7 F parameters, the same PROFIsafe address has been parameterized for the F modules parameterized in the specific machine data. This means that a clear communications relationship between the F master and F slave is not possible.
Response	Mode group not ready Channel not ready NC start inhibit in this channel Interface signals are set Alarm display NC stop for alarm
Remedy	Check and correct the S7 F parameterization and NCK–MD.
Program continuation	Power–down the control and power–up again
27225	PROFIsafe: Slave %1, configuration error, %2
Parameters	%1 = PROFIBUS slave address %2 = configuration error
Explanation	An error has occurred during the evaluation of the S7 PROFIBUS configuration for the specific slave. This is specified in more detail in the alarm parameter. %2 = PRM header: The PRM telegram for this slave could not clearly be interpreted.
Response	Mode group not ready Channel not ready NC start inhibit in this channel Interface signals are set Alarm display NC stop for alarm
Remedy	Check the S7 PROFIBUS configuration and correct.
Program continuation	Power–down the control and power–up again

27240	PROFIsafe: DP M has not run-up, DP info: %1
Parameters	%1 = actual information from the DP interface NCK-PLC
Explanation	There is no DP configuration available to the NCK after the time specified using the MD \$MN_PLC_RUNNINGUP_TIMEOUT.
Response	Mode group not ready Channel not ready NC start inhibit in this channel Interface signals are set Alarm display NC stop for alarm
Remedy	Increase MD \$MN_PLC_RUNNINGUP_TIMEOUT Check the PLC operating state Check the PLC operating system software release Delete the F parameterization in the NCK-MD
Program continuation	Power-down the control and power-up again
27241	PROFIsafe: DP M version different, NCK: %1, PLC: %2
Parameters	%1 = version of the DP interface on the NCK side %2 = version of the DP interface on the PLC side
Explanation	The DP interface has been implemented differently for the NCK and PLC components. The F communications cannot be initialized
Response	Mode group not ready Channel not ready NC start inhibit in this channel Interface signals are set Alarm display NC stop for alarm
Remedy	Check the PLC operating system and correct NCK software versions. Upgrade the PLC operating system. Delete NCK F parameterization.
Program continuation	Power-down the control and power-up again

8.2 Alarms for Sinumerik 840D

27242	PROFIsafe: F module %1, %2 faulty
Parameters	%1 = PROFIsafe address %2 = F parameter error
Explanation	An error was detected while evaluating F parameters. %2 = CRC1: CRC error, F parameters. %2 = F_WD_Timeout: The monitoring time parameterized in Step 7 is too short for the PROFIsafe cycle time defined by the MD \$MN_PROFISAFE_IPO_TIME_RATIO. %2 = CRC2_Len: Incorrect length of the telegram CRC. %2 = F_Data_Len: Incorrect telegram length has been defined for the stated module.
Response	Mode group not ready Channel not ready NC start inhibit in this channel Interface signals are set Alarm display NC stop for alarm
Remedy	%2 = CRC1: General PLC reset, reload the S7 F configuration. %2 = F_WD_Timeout: Re-parameterize the PROFIsafe clock cycle time or F monitoring time. %2 = CRC2_Len: General PLC reset, reload the S7 F configuration. %2 = F_Data_Len: General PLC reset, reload the S7 F configuration.
Program continuation	Power-down the control and power-up again
27250	PROFIsafe: Configuration in DP-M changed; error code %1 – %2
Parameters	%1 = NCK project number %2 = current PLC project number
Explanation	The DP master indicates a modified S7 PROFIBUS configuration. Error-free operation can no longer be guaranteed.
Response	Mode group not ready Channel not ready NC start inhibit in this channel Interface signals are set Alarm display NC stop for alarm Communications with the F slaves is terminated. A STOP D/E is initiated (this can be set using MD \$MN_SPL_STOP_MODE) on all of the axes with safety functionality.
Remedy	Restart the PLC/NCK
Program continuation	Power-down the control and power-up again

27251	PROFIsafe: F module %1, %2 reports error %3
Parameters	%1 = PROFIsafe address %2 = signaling components (master/slave) %3 = error detection
Explanation	An error has occurred in the PROFIsafe communications between the F master and the specified F module which was detected by the component (master/slave) displayed in parameter %2. The error code specifies the error type: <ul style="list-style-type: none"> – %3 = TO: The parameterized communications timeout has been exceeded – %3 = CRC: A CRC error was detected – %3 = CN: An error was detected in the sequence (timing) of the F telegrams – %3 = SF: F master error, NCK/PLC are no longer in synchronism – %3 = EA: Communications error, slave sends empty telegrams
Response	Mode group not ready Channel not ready NC start inhibit in this channel Interface signals are set Alarm display NC stop for alarm A STOP D/E is initiated (this can be set using MD \$MN_SPL_STOP_MODE) on all of the axes with safety functionality.
Remedy	Check the DP wiring. Restart the F slave modules. Restart the NCK/PLC.
Program continuation	Clear the alarm with the RESET key. Restart the part program.
27252	PROFIsafe: Slave %1, sign-of-live error
Parameters	%1 = DP slave address
Explanation	The specified DP slave no longer communicates with the master. Stop D/E is triggered.
Response	Mode group not ready Channel not ready NC start inhibit in this channel Interface signals are set Alarm display NC stop for alarm A STOP D/E is initiated (this can be set using MD \$MN_SPL_STOP_MODE) on all of the axes with safety functionality.
Remedy	Check the DP wiring. Restart the F slave modules. Restart the NCK/PLC.
Program continuation	Clear the alarm with the RESET key. Restart the part program.

8.2 Alarms for Sinumerik 840D

27253 PROFIsafe: Communications fault F master component %1, error %2

Parameters	%1 = faulty components (NCK/PLC) %2 = error detection
Explanation	The F master signals a communications error between the NCK and PLC. The cause of the error is indicated in error code %1: <ul style="list-style-type: none"> – %1 = NCK: Link between PROFIsafe and SPL interface is interrupted. – %1 = PLC: The PLC no longer executes the OB40 request. – %1 = PLC–DPM: DP master is no longer in the OPERATE state. Parameter %2 provides additional information about the reason for the error: <ul style="list-style-type: none"> – %2 = 0: NCK–internal sequence error (refer to %1=NCK). – %2 = 1,2,4: PLC processing of the OB40 not finished.
Response	Mode group not ready Channel not ready NC start inhibit in this channel Interface signals are set Alarm display NC stop for alarm A STOP D/E is initiated (this can be set using MD \$MN_SPL_STOP_MODE) on all of the axes with safety functionality.
Remedy	Extend the PROFIsafe cycle time using MD \$MN_PROFISAFE_IPO_TIME_RATIO.
Program continuation	Clear the alarm with the RESET key. Restart the part program.

27254 PROFIsafe: F module %1, error on channel %2; %3<ALSI>

Parameters	%1 = PROFIsafe address %2 = channel number %3 = supplementary info, system variables – field index
Explanation	The F module signals that an error has occurred in the interface of the specified channel. The alarm is only triggered for ET200S F modules. %2=0: Special significance, a general fault/error has occurred in the F module. Using parameter %3, a specific alarm message can be configured on the HMI for each of the listed system variables: <ul style="list-style-type: none"> – %3 = 1...64: Error in system variables \$A_INSE[1...64] – %3 = 65...128: Error in system variables \$A_OUTSE[1...64] – %3 = –1: Error in the input or output channel for which there is no SPL assignment

Response	Mode group not ready Channel not ready NC start inhibit in this channel Interface signals are set Alarm display NC stop for alarm A STOP D/E is initiated (this can be set using MD \$MN_SPL_STOP_MODE) on all of the axes with safety functionality.
Remedy	Check the wiring. Wiring OK: Replace the F module.
Program continuation	Clear the alarm with the RESET key. Restart the part program.
27255	PROFIsafe: F module %1, general error
Parameters	%1 = PROFIsafe address
Explanation	The specified PROFIsafe module signals an error: More detailed information on the cause of the error cannot be made without further resources. This alarm is triggered for all types of PROFIsafe slaves.
Response	Mode group not ready Channel not ready NC start inhibit in this channel Interface signals are set Alarm display NC stop for alarm
Remedy	Check the wiring.
Program continuation	Clear the alarm with the RESET key. Restart the part program.
27256	PROFIsafe: Actual cycle time %1 [ms] > parameterized cycle time
Parameters	%1 = actual PROFIsafe communications cycle time
Explanation	The actual PROFIsafe communication cycle time is greater than the value set using MD \$MN_PROFISAFE_IPO_TIME_RATIO. The parameterized PROFIsafe communication cycle time is continually exceeded on the PLC side.
Response	Mode group not ready NC start inhibit in this channel Interface signals are set Alarm display NC stop for alarm
Remedy	Adapt the cycle time using MD \$MN_PROFISAFE_IPO_TIME_RATIO. At least the value, displayed in parameter %1 must be set. The selected cycle time has an effect on the runtime utilization of the PLC module. This must be taken into account in the setting.
Program continuation	Clear the alarm with the RESET key. Restart the part program.

27299	PROFIsafe: Diagnostics %1 %2 %3 %4
Parameters	%1 error ID 1 %2 error ID 2 %3 error ID 3 %4 error ID 4
Explanation	Internal error in the NCK PROFIsafe implementation.
Response	Alarm display
Remedy	Please contact the Siemens A&D MC, Hotline with the error text – Tel 0180 / 5050 – 222 (Germany) – Fax 0180 / 5050 – 223 – Tel +49–180 / 5050 – 222 (outside Germany) – Fax +49–180 / 5050 – 223 – mailto:techsupport@ad.siemens.de
Program continuation	Power–down the control and power–up again

8.3 Alarms from SIMODRIVE 611digital

Alarms that may occur in connection with SINUMERIK Safety Integrated are listed below:

300500	Axis %1 drive %2 system error, error codes %3, %4
Parameters	%1 = NC axis number %2 = drive number %3 = error code 1 %4 = error code 2
Explanation	The drive has signaled a system error. Safety Integrated: Interrogation: In the corresponding clock cycle. For FD: Regenerative stop (corresponds to STOP B) For MSD: Pulse and controller inhibit (corresponds to STOP A) The error occurs if the computation time of the drive processor is not sufficient for the clock cycle indicated in the supplementary information. Error No.: 03, supplementary information: 40, monitoring clock cycle for SINUMERIK Safety Integrated too low.
Response	NC not ready Channel not ready NC stop for alarm NC start inhibit in this channel NC switches into the tracking mode Alarm display Interface signals are set
Remedy	Increase the relevant clock cycle or the subordinate clock cycle (e.g. current-control, speed-control or position-control clock cycle) or de-select functions that are not required.
Program continuation	Power-down the control and power-up again
300743	Axis %1 drive %2 function not supported on this 611D controller module
Parameters	%1 = NC axis number %2 = drive number
Explanation	The 611D Performance control module is required for SINUMERIK Safety Integrated. If this hardware has not been installed, this alarm is triggered. The alarm is also triggered if 1PH2/4/6 motors are connected but neither a 611D Performance control module nor a 611D Standard 2 control module is available. Interrogation: When the control is running-up.

8.3 Alarms from SIMODRIVE 611digital

Response	Mode group not ready Channel not ready NC start inhibit in this channel NC stop for alarm Alarm display Interface signals are set
Remedy	Replace the 611digital control module.
Program continuation	Power-down the control and power-up again
300744	Axis %1, drive %2 checksum error safe monitoring functions acknowledgment and acceptance test required!
Parameters	%1 = NC axis number %2 = drive number
Explanation	The actual checksum over the safety-related MDs calculated by the drive and saved in MD 1398: \$MD_SAFE_ACT_CHECKSUM (displays the checksum of the machine data for safe functions) has another value than the reference checksum saved during the last machine acceptance in MD 1399: \$MD_SAFE_DES_CHECKSUM (checksum of the machine data for safety-related functions). The safety-related data has been modified or there is an error.
Response	Mode group not ready Channel not ready NC start inhibit in this channel NC stop for alarm Alarm display Interface signals are set
Remedy	Check all safety-related MDs and if necessary correct. Then carry-out a power on. Carry-out an acceptance test on the machine.
Program continuation	Power-down the control and power-up again
300745	Axis %1, drive %2 limit values for safe end positions exchanged
Parameters	%1 = NC axis number %2 = drive number
Explanation	The data for the upper limit for the SE monitoring function contains a lower value than the data for the lower limit. Interrogation: When the control is running-up.
Response	Mode group not ready Channel not ready NC start inhibit in this channel NC stop for alarm Alarm display Interface signals are set

Remedy	Check the following MDs: MD 1334: \$MD_SAFE_POS_LIMIT_PLUS[n] (upper limit value for the safe limit position) and MD 1335: \$MD_SAFE_POS_LIMIT_MINUS[n] (lower limit value for the safe limit position) and change so that the upper limit value is greater than the lower limit value.
Program continuation	Power-down the control and power-up again
300746	Axis %1, drive %2 SBH/SG not enabled
Parameters	%1 = NC axis number %2 = drive number
Explanation	In MD 1301: \$MD_SAFE_FUNCTION_ENABLE (enable safety functions) the function SBH/SG has not been enabled although the function SE/SN has been selected in this MD. Interrogation: When the control is running-up.
Response	Mode group not ready Channel not ready NC start inhibit in this channel NC stop for alarm Alarm display Interface signals are set
Remedy	Enable the function SBH/SG using MD 1301: \$MD_SAFE_FUNCTION_ENABLE (enable safety functions).
Program continuation	Power-down the control and power-up again
300747	Axis %1, drive %2 invalid monitoring clock cycle for MD 1300
Parameters	%1 = NC axis number %2 = drive number
Explanation	The MD 1300: \$MD_SAFETY_CYCLE_TIME (monitoring clock cycle) was not set as a multiple of the NC position controller clock cycle. Interrogation: When the control is running-up.
Response	Mode group not ready Channel not ready NC start inhibit in this channel NC stop for alarm Alarm display Interface signals are set
Remedy	Using MD 1300, set the monitoring clock cycle to n * NC position control clock cycles. Note that n must be >= 1.
Program continuation	Power-down the control and power-up again

8.3 Alarms from SIMODRIVE 611digital

300748	Axis %1, drive %2 monitoring clock cycle not identical for both axes
Parameters	%1 = NC axis number %2 = drive number
Explanation	The monitoring clock cycle in MD 1300: \$MD_SAFETY_CYCLE_TIME (monitoring clock cycle) was not set to the same values for the two axes of a 2-axis module. Interrogation: When the control is running-up.
Response	Mode group not ready Channel not ready NC start inhibit in this channel NC stop for alarm Alarm display Interface signals are set
Remedy	Set MD 1300: \$MD_SAFETY_CYCLE_TIME (monitoring clock cycle) the same on all drives of the module.
Program continuation	Power-down the control and power-up again
300749	Axis %1, drive %2 conversion factor between motor and load too large
Parameters	%1 = NC axis number %2 = drive number
Explanation	The factor to convert from the motor system [increments] to the load system [$\mu\text{m}/\text{mDegrees}$] is greater than 1 or the factor which converts the load system to the motor system is greater than 65535. Conditions: The condition for the factor to convert from the load system to motor system is: $\mu\text{m_to_incr} \leq 65535$ The condition for the factor to convert from the motor system to load system is: $\text{incr_to_}\mu\text{m} \leq 1$ with $\mu\text{m_to_incr} = 1 / \text{incr_to_}\mu\text{m}$ Formula for rotary axis: The following applies for rotary motor encoder and rotary axis: $\text{incr_to_}\mu\text{m}(n) = (\text{MD1321 SAFE_ENC_GEAR_DENOM}(n) / (\text{MD1322 SAFE_ENC_NUMERA}(n)) * \text{incr_to_}\mu\text{m_rot_rund}$ with $n = 0 \dots 7$ (gearbox stage) and $\text{incr_to_}\mu\text{m_rot_rund} = (360000 / 8192) * (1 / \text{MD1318 SAFE_ENC_RESOL})$ <ul style="list-style-type: none"> • MD 1318 SAFE_ENC_RESOL (number of encoder pulses per revolution) • MD 1321 SAFE_ENC_GEAR_DENOM[n] (encoder/load gear ratio denominator) • MD 1322 SAFE_ENC_GEAR_NUMERA[n] (encoder/load gear ratio numerator) Formula for linear axis: The following applies for a rotary motor encoder and linear axis: $\text{incr_to_}\mu\text{m}(n) = (\text{MD1321 SAFE_ENC_GEAR_DENOM}(n) /$

	$(MD1322 \text{ SAFE_ENC_NUMERA}(n)) * \text{incr_to_}\mu\text{m_rot_lin}$ $\text{incr_to_}\mu\text{m_rot_lin} = (1000 / 8192) * (1 / MD1318 \text{ SAFE_ENC_RESOL})$ $* MD1320 \text{ SAFE_ENC_GEAR_PITCH}$
	<p>Explanation:</p> <ul style="list-style-type: none"> • MD 1318 SAFE_ENC_RESOL (number of encoder pulses per revolution) • MD 1320 SAFE_ENC_GEAR_PITCH (spindle pitch) • MD 1321 SAFE_ENC_GEAR_DENOM[n] (encoder/load gear ratio denominator) • MD 1322 SAFE_ENC_GEAR_NUMERA[n] (encoder/load gear ratio denominator) • n = 0 ... 7 (gearbox stage) <p>Interrogation: When the control is running-up.</p>
Response	<p>Mode group not ready Channel not ready NC start inhibit in this channel NC stop for alarm Alarm display Interface signals are set</p>
Remedy	<p>Please inform authorized personnel/service department. Check the following safety-related MDs depending on the motor encoder type and axis type and correct, if necessary.</p> <ul style="list-style-type: none"> • MD 1317 SAFE_ENC_GRID_POINT_DIST grid division, linear scale (for linear encoder) • MD 1318 SAFE_ENC_RESOL encoder pulses per revolution (for a rotary encoder) • MD 1318 SAFE_ENC_RESOL • MD 1320 SAFE_ENC_GEAR_PITCH (for a rotary encoder and linear axis) • MD 1321 SAFE_ENC_GEAR_DENOM • MD 1322 SAFE_ENC_GEAR_NUMERA (when using a gearbox) • The motor encoder type and the axis type are specified using MD 1302 SAFE_IS_ROT_AX
Program continuation	Power-down the control and power-up again
300776	Axis %1, drive %2 measuring circuit monitoring must be active
Parameters	<p>%1 = NC axis number %2 = drive number</p>
Explanation	<p>For FD: The controllers are inhibited, the motor is braked, SIMODRIVE_READY and DRIVE_READY are withdrawn.</p> <p>For MSD: The pulses are cancelled, the motor coasts down, SIMODRIVE_READY and DRIVE_READY are withdrawn.</p> <p>Note: The response (FD, MSD) can be configured using 611D-MD 1613.0.</p>

8.3 Alarms from SIMODRIVE 611digital

	<p>Interrogation: When the control runs-up and cyclically. For active Safety Integrated (MD 1301 <> 0: \$MD_SAFE_FUNC-TION_ENABLE (enable safety functions)), the measuring circuit monitoring of the motor (incremental) must be activated using MD 1600: \$MD_ALARM_MASK_POWER_ON (alarms that can be suppressed (power on)) bit 4.</p>
Response	<p>Mode group not ready Channel not ready NC start inhibit in this channel NC stop for alarm Alarm display Interface signals are set</p>
Remedy	<p>Please inform authorized personnel/service department. Activate the measuring circuit monitoring of the motor (incremental).</p>
Program continuation	<p>Power-down the control and power-up again</p>
300900	Axis %1, drive %2 STOP A initiated
Parameters	<p>%1 = NC axis number %2 = drive number</p>
Explanation	<p>The drive is stopped using STOP A. This inhibits the pulses using the relay "Antrieb_IMP" ["Drive_IMP"]. Interrogation: In the monitoring clock cycle. If STOP A has been triggered, this can have several reasons:</p> <ul style="list-style-type: none"> - The timer in MD 1356: \$MD_SAFE_PULSE_DISABLE_DELAY (delay time, pulse cancellation) of STOP B has expired. - The speed threshold in MD 1360: \$MD_SAFE_STANDSTILL_VELO_TOL (shutdown speed, pulse cancellation) of STOP B has not been reached. - The user has requested that the shutdown path is tested using SGE "Test stop selection", but the pulses were not cancelled after the timer stage in MD 1357: \$MD_SAFE_PULSE_DIS_CHECK_TIME (time to test the pulse cancellation) has expired. - Safe braking ramp (SBR) has responded. - "SG-specific stop response" is set to STOP A and has responded. <p>The alarm can be re-configured in the MD ALARM_REACTION_CHAN_NOREADY (channel not ready).</p>
Response	<p>Mode group not ready Channel not ready NC start inhibit in this channel NC stop for alarm Alarm display Interface signals are set</p>
Remedy	<p>Please inform authorized personnel/service department. The user must identify the cause and take the appropriate measures.</p>
Program continuation	<p>Power-down the control and power-up again</p>

300901	Axis %1, drive %2 STOP B initiated
Parameters	%1 = NC axis number %2 = drive number
Explanation	The drive is stopped using STOP B. This inhibits the pulses using the relay "Antrieb_IMP" ["Drive_IMP"]. Interrogation: In the monitoring clock cycle. If STOP B has been triggered, this can have several reasons: <ul style="list-style-type: none"> – Safe standstill monitoring has responded. – Call for STOP F, i.e. a crosswise data comparison error has occurred. – The "SG-specific stop response" is set to STOP B and has responded. The alarm can be re-configured in the MD ALARM_REACTION_CHAN_NOREADY (channel not ready).
Response	Mode group not ready Channel not ready NC start inhibit in this channel NC stop for alarm Alarm display Interface signals are set
Remedy	Please inform authorized personnel/service department. The user must identify the cause and take the appropriate measures.
Program continuation	Power-down the control and power-up again
300906	Axis %1, drive %2 safe braking ramp exceeded
Parameters	%1 = NC axis number %2 = drive number
Explanation	The drive is stopped using STOP A. Interrogation: In the monitoring clock cycle. The actual speed of the axis has not decreased when braking with "n _{set} = 0" (STOP B or STOP C), but has increased again above the speed limit corrected by braking and the tolerance specified in MD 1348: \$MD_SAFE_VELO_TOL (actual speed tolerance for SBR). The alarm can be re-configured in the MD ALARM_REACTION_CHAN_NOREADY (channel not ready).
Response	Mode group not ready Channel not ready NC start inhibit in this channel NC stop for alarm Alarm display Interface signals are set
Remedy	Please inform authorized personnel/service department. Check the braking characteristics and, if necessary, modify the speed tolerance in MD 1348: \$MD_SAFE_VELO_TOL (actual speed tolerance for SBR). Restart is only possible with power on.
Program continuation	Power-down the control and power-up again

8.3 Alarms from SIMODRIVE 611digital

300907	Axis %1, drive %2 tolerance for safe operating stop exceeded
Parameters	%1 = NC axis number %2 = drive number
Explanation	The drive is stopped using STOP A or STOP B. This inhibits the pulses using the relay "Antrieb_IMP" ["Drive_IMP"]. Interrogation: In the monitoring clock cycle. The actual position has moved too far away from the setpoint/standstill position (outside the standstill window). The standstill window is parameterized using MD 1330: \$MD_SAFE_STANDSTILL_TOL (standstill tolerance SBH).
Response	Mode group not ready Channel not ready NC start inhibit in this channel NC stop for alarm Alarm display Interface signals are set
Remedy	Please inform authorized personnel/service department. Check the tolerance for the safe operating stop: does the value match the precision and control dynamic performance of the axis? If not, increase the tolerance.
Program continuation	Power-down the control and power-up again
300908	Axis %1, drive %2 STOP C initiated
Parameters	%1 = NC axis number %2 = drive number
Explanation	The drive is stopped using STOP C. At the end of the stop response, the drive remains in closed-loop control, the axis is monitored for SBH. Interrogation: In the monitoring clock cycle. If a STOP C was initiated, then this can have several reasons (depending on what has been configured): <ul style="list-style-type: none"> - The safely-reduced speed monitoring has responded (MD 1361: \$MD_SAFE_VELO_STOP_MODE (stop response, safely-reduced speed) or MD 1363: \$MD_SAFE_VELO_STOP_REACTION (SG-specific stop response)). - The safe limit-position monitoring has responded (MD 1362: \$MD_SAFE_POS_STOP_MODE (safe limit position, stop response)). The alarm indicates that "braking at the current limit" has been initiated and the internal activation of "safe operating stop".

Response	NC start inhibit in this channel NC stop for alarm Alarm display Interface signals are set
Remedy	Please inform authorized personnel/service department. The user must identify the cause and take the appropriate measures.
Program continuation	Clear the alarm with the RESET key. Restart the part program.

300909**Axis %1, drive %2 STOP D initiated**

Parameters	%1 = NC axis number %2 = drive number
Explanation	<p>The drive is stopped by the NC with a STOP D. At the end of the stop response, the drive remains in closed-loop control, the axis is monitored for SBH.</p> <p>Interrogation: In the monitoring clock cycle.</p> <p>If a STOP D was initiated, this can have several reasons (depending on what has been configured):</p> <ul style="list-style-type: none"> – The safely-reduced speed monitoring has responded (MD 1361: \$MD_SAFE_VELO_STOP_MODE (stop response, safely-reduced speed) or MD 1363: \$MD_SAFE_VELO_STOP_REACTION (SG-specific stop response). – The safe limit-position monitoring has responded (MD 1362: \$MD_SAFE_POS_STOP_MODE (safe limit position, stop response)). <p>The alarm indicates that a "braking along the path" has been initiated on the NC side and the internal activation of "safe operating stop" in the NC and drive.</p>

Response	NC start inhibit in this channel NC stop for alarm Alarm display Interface signals are set
Remedy	Please inform authorized personnel/service department. The user must identify the cause and take appropriate measures.
Program continuation	Clear the alarm with the RESET key. Restart the part program.

300910**Axis %1, drive %2 STOP E initiated**

Parameters	%1 = NC axis number %2 = drive number
Explanation	<p>The drive is stopped by the NC with a STOP E. At the end of the stop response, the drive remains in closed-loop control, the axis is monitored for SBH.</p> <p>Interrogation: In the monitoring clock cycle.</p> <p>If a STOP E was initiated, this can have several reasons (depending on what has been configured):</p>

8.3 Alarms from SIMODRIVE 611digital

	<ul style="list-style-type: none"> – The safely–reduced speed monitoring has responded (MD 1361: \$MD_SAFE_VELO_STOP_MODE (stop response, safely–reduced speed). – The safe limit–position monitoring has responded (MD 1362: \$MD_SAFE_POS_STOP_MODE (safe limit position, stop response). <p>The alarm indicates that an "external stop and retract ESR" has been initiated on the NC side (840C) or "LIFTFAST–ASUB" (840D) and the internal activation of "safe operating stop" in the NC and drive.</p>
Response	<p>NC start inhibit in this channel NC stop for alarm Alarm display Interface signals are set</p>
Remedy	Please inform authorized personnel/service department. The user must identify the cause and take appropriate measures.
Program continuation	Clear the alarm with the RESET key. Restart the part program.
300911	Axis %1, drive %2 error in one monitoring channel
Parameters	<p>%1 = NC axis number %2 = drive number</p>
Explanation	The mutual comparison of the two monitoring channels has found a difference between input data or results of the monitoring functions. One of the monitoring functions no longer functions reliably, i.e. safe operation is no longer possible.
Response	Alarm display
Remedy	<p>Please inform authorized personnel/service department. Identify the difference between the monitoring channels. The error code indicating the cause is displayed as follows: For 840D the error code is output in the alarm text For 611D MD 1395: \$MD_SAFE_STOP_F_DIAGNOSIS (diagnostics for STOP F) This significance of the error code can be identified as follows: For 840D: Description of Alarm 27001 The safety–related machine data might not be identical or the SGEs might not be at the same level (re–measure or check in the SI service screen). If no error of this type is apparent, an error may have occurred in the CPU, e.g. a "flipped" memory cell. This error can be temporary (in this case it can be eliminated by a POWER ON) or permanent (if it re–occurs again after POWER ON replace the hardware).</p>
Program continuation	Clear the alarm with the RESET key. Restart the part program.

300914	Axis %1, drive %2 safely-reduced speed exceeded
Parameters	%1 = NC axis number %2 = drive number
Explanation	The drive is stopped using the response configured in MD 1361: \$MD_SAFE_VELO_STOP_MODE. At the end of the stop response, the drive remains in closed-loop control, the axis is monitored for SBH. Interrogation: In the monitoring clock cycle. The axis has moved faster than that specified in MD 1331: \$MD_SAFE_VELO_LIMIT[n] (limit values for safely-reduced speed). If the function "correction, safely-reduced speed" in MD 1301: \$MD_SAFE_FUNCTION_ENABLE has been enabled (enable safety functions), then, for SG2 and SG4, the entered correction factor must be taken into account for the permissible speed.
Response	NC start inhibit in this channel NC stop for alarm Alarm display Interface signals are set
Remedy	Please inform authorized personnel/service department. Check the machine data values that have been entered. Check the safe input signals: Is the correct one of the four speed limits selected?
Program continuation	Clear the alarm with the RESET key. Restart the part program.
300915	Axis %1, drive %2 safe end positions exceeded
Parameters	%1 = NC axis number %2 = drive number
Explanation	The drive is stopped using the response configured in MD 1362: \$MD_SAFE_POS_STOP_MODE. At the end of the stop response, the drive remains in closed-loop control, the axis is monitored for SBH. Interrogation: In the monitoring clock cycle. The axis has exceeded the limit position (i.e. endstop) that is entered in <ul style="list-style-type: none"> • MD 1334: \$MD_SAFE_POS_LIMIT_PLUS[n] (upper limit for safe limit position) • MD 1335: \$MD_SAFE_POS_LIMIT_MINUS[n] (lower limit for safe limit position).
Response	NC start inhibit in this channel NC stop for alarm Alarm display Interface signals are set
Remedy	Please inform authorized personnel/service department. If no obvious operator error has occurred: Check the value entered in the machine data, check the SGEs: Was the correct one of 2 limit positions selected? If the MDs and SGEs are o.k., check the machine for any damage and repair.
Program continuation	Clear the alarm with the RESET key. Restart the part program.

8.3 Alarms from SIMODRIVE 611digital

300950	Axis %1, drive %2 axis not safely referenced
Parameters	%1 = NC axis number %2 = drive number
Explanation	No stop response is initiated. When the SN/SE functions are enabled, the message remains until the axis state "Axis safely referenced" has been reached. Interrogation: In the monitoring clock cycle. <ul style="list-style-type: none"> – Axis is not safely referenced, or – User agreement for this axis is missing or has been withdrawn. This can occur, for example, if the axis was moved after the machine was powered-down and the standstill position that was saved is therefore no longer correct. The message prompts the user to confirm the actual position. To do this, you must determine the position, e.g. as follows: <ul style="list-style-type: none"> – Measure the position – Move to a known position
Response	Alarm display
Remedy	Please inform authorized personnel/service department. If the axis cannot be automatically and safely referenced, then the user must enter a "user agreement" for the new position using the appropriate softkey. This user agreement identifies this position as safe – that means the axis status "Axis safely referenced" is reached. Warning: If the axis has not been safely referenced and the user has not issued a user agreement, then the following applies: <ul style="list-style-type: none"> – The safe cams are active, but not yet safe – The safe limit positions are not yet active
Program continuation	The alarm is no longer displayed when the alarm cause has been removed. No other operator actions are required.

300951	Axis %1, drive %2 test stop running
Parameters	%1 = NC axis number %2 = drive number
Explanation	<p>The drive pulses are cancelled.</p> <ul style="list-style-type: none"> • If the positive acknowledgment that the pulses were cancelled is not received within the time configured in MD 1357: \$MD_SAFE_PULSE_DIS_CHECK_TIME (time to check the pulse cancellation), a STOP A is triggered. • If pulse cancellation is acknowledged within the configured time in the drive, no stop response is triggered. When selected via the SGE "test stop selection", the message remains until the selection has been withdrawn (de-selected). The user activated the test stop by setting the SGE "test stop selection". If the user withdraws this SGE, then the message is also withdrawn. <p>Interrogation: In the monitoring clock cycle.</p> <p>The test stop has been activated by the user by setting the SGE "test stop selection". The drive pulses are cancelled.</p> <ul style="list-style-type: none"> • If the positive acknowledgment that the pulses were cancelled is not received within the time configured in MD 1357: \$MD_SAFE_PULSE_DIS_CHECK_TIME (time to check the pulse cancellation), a STOP A is triggered. • If pulse cancellation is acknowledged within the configured time in the drive, no stop response is triggered. When selected via the SGE "test stop selection", the message remains until the selection has been withdrawn (de-selected).
Response	Alarm display
Remedy	The message disappears automatically if the user terminates the test by withdrawing the SGE "test stop selection". If a STOP A was initiated, then the system can only be re-started using a power on.
Program continuation	The alarm is no longer displayed when the alarm cause has been removed. No other operator actions are required.
300952	Axis %1 drive %2 acceptance test mode is active
Parameters	%1 = axis number %2 = drive number
Explanation	The acceptance test mode has been activated by the user.
Response	Alarm display
Remedy	This message disappears automatically when the test is completed.
Program continuation	The alarm is no longer displayed when the alarm cause has been removed. No other operator actions are required.

8.3 Alarms from SIMODRIVE 611digital

301701	Axis %1, drive %2 limit value for safely-reduce speed too large
Parameters	%1 = NC axis number %2 = drive number
Explanation	The run-up sequence is interrupted. The pulses remain cancelled. Interrogation: In the monitoring clock cycle. The limit value set for the safely-reduced speed is higher than the speed that corresponds to a limit frequency of 200 kHz (300 kHz for 840D from SW 4.2). The max. permissible speed that can be monitored is determined as follows: $n_{max}[\text{rev/min}] = (200000[\text{Hz}] * 60) / \text{number of encoder pulses}$ Monitoring condition: MD 1331: $\$MD_SAFE_VELO_LIMIT[n] \leq (1 / ue) * n_{max}$
Response	Mode group not ready Channel not ready NC start inhibit in this channel NC stop for alarm Alarm display Interface signals are set
Remedy	Please inform authorized personnel/service department. Check the entry in machine data MD 1331: $\$MD_SAFE_VELO_LIMIT[n]$ (limit values for safely-reduced speed) correct, if necessary, and carry-out a POWER ON.
Program continuation	Power-down the control and power-up again
301706	Axis %1, drive %2 parameterization of cam position invalid
Parameters	%1 = NC axis number %2 = drive number
Explanation	At least one of the parameterized cams enabled via MD 1301: $\$MD_SAFE_FUNCTION_ENABLE$ (enable safety-related functions) has failed to comply with the rule that cam positions may not be located within the tolerance range around the modulo position. The valid tolerance range is: <ul style="list-style-type: none"> • for inactive cam synchronization (MD 1301 bit 7 = 0): lower modulo value + POS_TOL ≤ cam position upper modulo value – POS_TOL > cam position • for active cam synchronization (MD 1301 bit 7 = 1): lower modulo value + POS_TOL ≤ cam position upper modulo value – POS_TOL – CAM_TOL > cam position Explanations: POS_TOL: Actual value tolerance (MD 1342: $\$MD_SAFE_POS_TOL$ (tolerance, crosswise actual value comparison)) CAM_TOL: Cam tolerance (MD 1340: $\$MD_SAFE_CAM_TOL$ (tolerance for safe cams))

	Lower/upper modulo value: is defined using MD 1305: \$MD_SAFE_MODULO_RANGE (for rotary axis, the actual value range)
Response	Mode group not ready Channel not ready NC start inhibit in this channel NC stop for alarm Alarm display Interface signals are set
Remedy	Please inform authorized personnel/service department. Check/correct parameter settings of cam positions in MD 1336: \$MD_SAFE_CAM_POS_PLUS (plus cam position for safe cams) or MD 1337: \$MD_SAFE_CAM_POS_MINUS (minus cam position for safe cams) and carry-out POWER ON. MD 1305: \$MD_SAFE_MODULO_RANGE (for rotary axes, the actual value range for SN).
Program continuation	Power-down the control and power-up again
301707	Axis %1, drive %2 invalid modulo value parameters for SN
Parameters	%1 = NC axis number %2 = drive number
Explanation	The cam modulo range parameterized in MD 1305: \$MD_SAFE_MODULO_RANGE (for rotary axes, the actual value range for SN) for a rotary axis has failed to comply with the rule that only a multiple integer of 360 degrees may be set.
Response	Mode group not ready Channel not ready NC start inhibit in this channel NC stop for alarm Alarm display Interface signals are set
Remedy	Please inform authorized personnel/service department. Change the parameterization of the cam modulo range in MD 1305 : \$MD_SAFE_MODULO_RANGE (for rotary axes, the actual value range for SN).
Program continuation	Power-down the control and power-up again

8.3 Alarms from SIMODRIVE 611digital

301708	Axis %1, drive %2 actual value synchronization not allowed
Parameters	%1 = NC axis number %2 = drive number
Explanation	The actual value synchronization for drift/slip in MD 1301: \$MD_SAFE_FUNCTION_ENABLE (enable safety-related functions) is selected. This is only permissible for SBH/SG because the absolute actual position is of no significance for these monitoring types. However, safe limit position and/or cam monitoring is also selected.
Response	Mode group not ready Channel not ready NC start inhibit in this channel NC stop for alarm Alarm display Interface signals are set
Remedy	Please inform authorized personnel/service department. De-select the actual value synchronization for drift/slip or the safe limit position and/or safe cam monitoring in MD 1301: \$MD_SAFE_FUNCTION_ENABLE (enable safety-related functions).
Program continuation	Power-down the control and power-up again

8.4 PLC alarms

400253	PLC–STOP due to an SPL system error
Explanation	After an interruption in the communications between NCK and PLC regarding the SPL crosswise data comparison, the PLC was switched into the STOP state with a delay of 5 s.
Response	Alarm display
Remedy	Do not start the SPL anymore. Check the system components (the PLC must have the correct version of the FB 15 and have DB18).
Program continuation	Remove the fault. Power–down the control and power–up again
411101	FB11, illegal axis number
Explanation	Parameter axis not in the permissible range
Response	Alarm display PLC stop
Remedy	PLC general reset, use the basic program with the correct version.
Program continuation	Remove the fault. Power–down the control and power–up again

8.5 Reducing the number of alarms

In some cases, alarms having the same significance are triggered by the NCK, PLC and 611digital monitoring channels. In order to make the alarm screen more transparent, the alarms that were triggered sometime later – but have the same significance – are suppressed or even an alarm that occurred earlier is cleared again if it apparently involves a subsequent (follow-on) fault/error.

Alarm suppression and alarm priority are not involved when it comes to initiating a stop through two channels. This functionality is implemented independently of the alarm being triggered and is still maintained.

8.5.1 Suppressing alarms

When the alarm suppression function is active, the alarm of the monitoring channel is displayed that first detected the fault/error that initiated the alarm.

This only applies to some of the alarms. Alarms whose information content differs depending on the monitoring channels are still separately displayed.

All of the NCK and 611digital safety alarms are shown in the following table, that can be suppressed with the appropriate parameterization of \$MN_SAFE_ALARM_SUPPRESS_LEVEL.

Table 8-1 Comparison of the NCK and 611digital safety alarms

NCK alarm number	611digital alarm number	Alarm suppression using the following values n \$MN_SAFE_ALARM_SUPPRESS_LEVEL, several values are alternatively possible.
27000	300950	3, 13, replaced by Alarm 27100
27010	300907	1, 2, 3, 12, 13
27011	300914	1, 2, 3, 12, 13
27012	300915	1, 2, 3, 12, 13
27013	300906	1, 2, 3, 12, 13
27020	300910	1, 2, 3, 12, 13
27021	300909	1, 2, 3, 12, 13
27022	300908	1, 2, 3, 12, 13
27023	300901	1, 2, 3, 12, 13
27024	300900	1, 2, 3, 12, 13

All of the NCK alarms are listed in the following table which can be prevented from being initiated twice due to a PLC request.

Table 8-2 NCK alarms initiated twice

NCK alarm number	Alarm suppression using the following values n \$MN_SAFE_ALARM_SUPPRESS_LEVEL, several values are alternatively possible.
27090	2, 3, 12, 13
27091	2, 3, 12, 13
27092	2, 3, 12, 13
27095	2, 3, 12, 13
27250	2, 3, 12, 13
27251	2, 3, 12, 13
27252	2, 3, 12, 13
27253	2, 3, 12, 13
27254	2, 3, 12, 13
27255	2, 3, 12, 13
27256	2, 3, 12, 13

Activating

The function is enabled using MD 10094 \$MN_SAFE_ALARM_SUPPRESS_LEVEL. When standard data is loaded, the function is already active. This means that a reduced number/scope of alarms is displayed. Alarms 27000 and 300950 can be replaced by Alarm 27100 using MD 10094.

Limitations

The MD is not incorporated in the axial safety MD checksum. This means that the function can be enabled/disabled at any time by changing the MD. In the acceptance test, the alarm suppression should be disabled so that the two-channel fault/error detection can be checked. It can then be subsequently activated in order to reduce the number of alarms that end users have to cope with.

8.5.2 Assigning priorities to alarms

Especially for machines with an extremely high number of axes, the previously described alarm suppression function is not adequate in order to obtain a display of the real fault/error codes.

Also without SPL, just one single input signal fault Alarm 27001 (or 27101 to 27107) can occur for many axes if this input signal is configured as SGE on several axes. The cause of the fault/error can be hidden as a result of the large alarm list.

This is the reason that priorities are assigned to Alarms 27090, 27004, 27001 and 27101 to 27107. For these alarms

8.5 Reducing the number of alarms

- a subsequent (follow-on) alarm that occurs afterwards is no longer displayed. This alarm is also not visible in the alarm log.
- a subsequent alarm that already occurred beforehand is cleared again. This alarm is then visible in the alarm log.

Assigning priorities to Alarm 27090 only becomes effective if it occurs due to differences in the \$A_INSE system variables. Only then will this alarm be triggered as a result of different input signals. For Alarms 27004, 27001 and 27101 to 21107, no additional condition is required, as

- Alarms 27001 and 27101 to 21107 cannot occur if a STOP B or a STOP A is already present. When the SI functionality is active, STOP B and STOP A always occur as subsequent error and do not provide the user with any additional information about the cause of the fault or error.
- Alarm 27004 only occurs if differences are determined in the input signals.

Subsequent alarm for Alarm 27090

If Alarm 27090 is output, the following alarms are no longer displayed:

- 27001 defect in a monitoring channel
- 27004 difference, safety inputs
- 27020 STOP E initiated
- 27021 STOP D initiated
- 27022 STOP C initiated
- 27023 STOP B initiated
- 27024 STOP A initiated
- 27091 error for crosswise data comparison, NCK-PLC
- 27101 difference for the function, safe operating stop
- 27102 difference for the function, safely-reduced speed
- 27103 difference for the function, safe end position
- 27104 difference for the function, safe cam plus
- 27105 difference for the function, safe cam minus
- 27106 difference for the function, safely-reduced speed nx
- 27107 difference for the function, cam modulo monitoring

Subsequent alarm for Alarm 27004

- 27001 defect in a monitoring channel
- 27023 STOP B initiated
- 27024 STOP A initiated
- 27101 difference for the function, safe operating stop
- 27102 difference for the function, safely-reduced speed
- 27103 difference for the function, safe end position
- 27104 difference for the function, safe cam plus
- 27105 difference for the function, safe cam minus
- 27106 difference for the function, safely-reduced speed nx
- 27107 difference for the function, cam modulo monitoring

Subsequent alarms for Alarms 27001 and 27101 to 27107

- 27023 STOP B initiated
- 27024 STOP A initiated

Activating

Priorities are assigned to alarms by appropriately parameterizing MD 10094 \$MN_SAFE_ALARM_SUPPRESS_LEVEL. When this MD is set to either 12 or 13, in addition to the alarm suppression, set with values 2 and 3, the function that assigns priorities to alarms is also activated.

Alarm 27124

By suppressing alarms, alarms with the power on clear criterion are also cleared or no longer displayed. In spite of this, the system is in a state in which a power on is required. If only Alarm 27024 "Stop A initiated" has occurred, but is no longer displayed, then at least group Alarm 27124 "Stop A for at least 1 axis" is displayed.

Interaction with Other Functions

9.1 SG-specific limiting of the setpoint velocity

The SG-specific setpoint velocity limiting acts in combination with "safety-reduced speed" (SG) and "safe operating stop" (SBH). This setpoint velocity limiting function prevents, through a single channel in the interpolator, that the active SG/SBH limit values are exceeded.

The function can, for example, be used to test a program with the protective doors open (mode 3).

In order to limit the speed setpoint as a function of the active safety monitoring, MD 36933: \$MA_SAFE_DES_VELO_LIMIT is specified. This machine data is not included in the axial checksum MD 36998: \$MA_SAFE_ACT_CHECKSUM, so that changes can be made to the MD for the acceptance test without having to again change the checksum.

MD = 0%:
Setpoint limiting not active

MD > 0%:
Setpoint limiting = active SG limit multiplied by the MD value
For SBH, setpoint limit = 0

MD = 100%:
Setpoint limit = active SG limit
For SBH, setpoint limit = 0

- The function is effective in one channel in the NCK interpolator. The safety monitoring channel provides a limit value that corresponds to the selected safety monitoring type.
- This function influences both axes and spindles
- The active setpoint limit can be viewed in the safety service screen:
Display value = -1. corresponds to "setpoint limiting not active"
Display value >= 0. corresponds to "setpoint limiting active"

 9.1 SG-specific limiting of the setpoint velocity

- The setpoint limit is changed-over when the SGE is changed-over:

SGE	"SBH/SG de-selection"
SGE	"SBH de-selection"
SGEs	"Active SG stage, bit 0,1"
SGEs	"SG override, bit 0, 1, 2, 3"

Further, internal changeover operations in SBH have an effect as a result of a stop response (STOP D, C, E)
- For the changeover via SGEs, the states from **both** monitoring channels are taken into consideration to take into account differences in the times. This results in the following rules:
 1. Changing-over from non-safe operation in SG/SBH
There is no delay (VELO_SWITCH_DELAY), so that this changeover must always be performed at zero speed or below the enabled SG limit.
 2. Changing-over from SGx to SGy
 - A) $SGx > SGy$ (braking): A lower setpoint is entered as soon as a changeover is detected in one of the two channels.
 - B) $SGx < SGy$ (accelerating): A higher setpoint is only entered if both channels have changed-over.
 3. Changing-over from SG to SBH (braking)
A lower setpoint (= 0) is entered as soon as the changeover has been detected in one of the two channels.
 4. Changing-over from SBH to SG (accelerating)
A higher setpoint is only entered if both channels have changed-over.
 5. Changing-over from SBH/SG into non-safe operation (accelerating)
A higher setpoint is only entered if both channels have changed-over.
- Effect of the function in the NCK interpolator:
 - Setpoint limiting is active in both the AUTO as well as in the JOG modes.
 - When changing-over while moving to higher safely-reduced speeds, the position control loop should be set so that it does not overshoot. This means that a sudden setpoint limit change does not cause the monitoring to respond on the actual value side.
 - When transformation is active, safety setpoint limits, axially effective in the interpolator are reduced by the transformation itself depending on the actual position.

Note

There are no restrictions for motion from synchronous actions.

9.2 Setpoint changeover (from SW 7.2)

The "setpoint changeover" function allows several axes to use a common drive. In order to define the axes that are to be involved in the setpoint changeover, the same drive setpoint channel is assigned a multiple number of times. To do this, MD 30110: CTRLOUT_MODULE_NR must be pre-assigned the logical drive number – and that for every axis.

A precise description of this function is provided in

Reference: /FB3/, Special Functions, S9

Setpoint changeover and Safety Integrated

In conjunction with the setpoint changeover, the SI functionality is only supported with a restricted scope. At each setpoint changeover, the absolute position reference is lost. This means that only SI functions can be sensibly and practically used that do not require absolute position information. These functions include SBH, SH, SG, SBR, Stops and SPL.

Notice

SE and SN are not supported.

The SI monitoring functions are only calculated in the axis configured for this – not taking into account existing drive checking functions. This means that only this SI machine axis detects SI fault/error states. The associated **alarm responses** are automatically effective for **all** of the axes involved in the setpoint changeover.

The MD 36901: SAFE_FUNCTION_ENABLE may only be activated in the **last** machine axis configured for the setpoint changeover. This fixed assignment is kept over all setpoint changeover operations.

In conjunction with Safety Integrated, all of the axes, involved in the setpoint changeover, must be configured in the **same** channel.

If the SI monitoring is also to be effective when traversing/moving non-SI axes, then it is not permissible that the SI axis is parked during this time.

An axis with the existing drive checking function DB3x.DBX96.5=1 must be parked **at the same time** as an SI axis. This means that the axis SI monitoring functions are de-activated synchronously in the drive and in the SI axis. Parking the axis – must always be selected for both axes.

The "parking" operating state can only be exited using the axis with the drive checking function.

9.2 Setpoint changeover (from SW 7.2)

1–encoder system

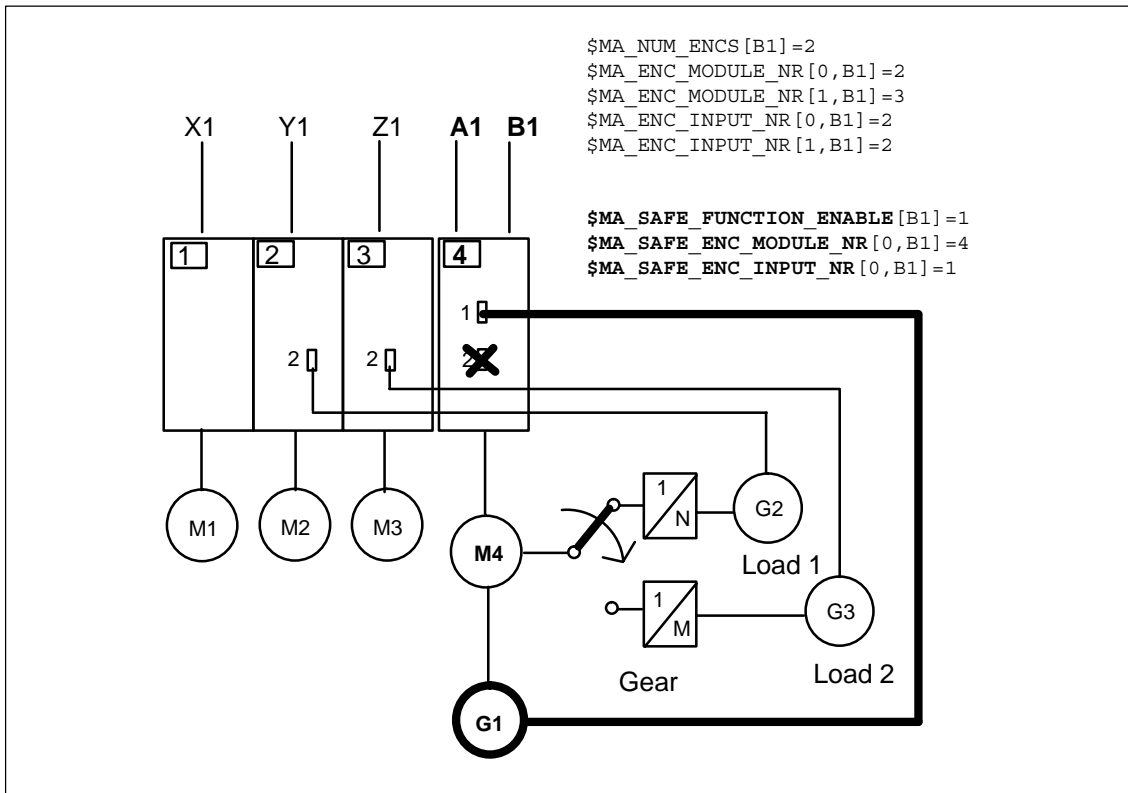

Fig. 9-1 Setpoint changeover in conjunction with a 1–encoder system

As a result of the mechanical changeover, the motor encoder (G1) – monitored using SI – is moved from several axes one after the other. In order to be able to determine the correct speed on the load side, the existing gearbox ratios of the axes involved must be sensibly emulated (mapped) in the 8 elements of MD 36921, 36922 of the SI axis and the drive MD 1321, 1322.

```

$MA_SAFE_ENC_GEAR_DENOM[0,B1]=M ;1st gearbox stage = axis A1
$MA_SAFE_ENC_GEAR_DENOM[0,B1]=1

```

...

```

$MA_SAFE_ENC_GEAR_DENOM[4,B1]=N ;1st gearbox stage = axis B1
$MA_SAFE_ENC_GEAR_DENOM[4,B1]=1

```

In order that the correct gearbox ratio factor becomes effective in the SI monitoring function, the PLC must select the associated SI gearbox ratio and change over the setpoint at the same time.

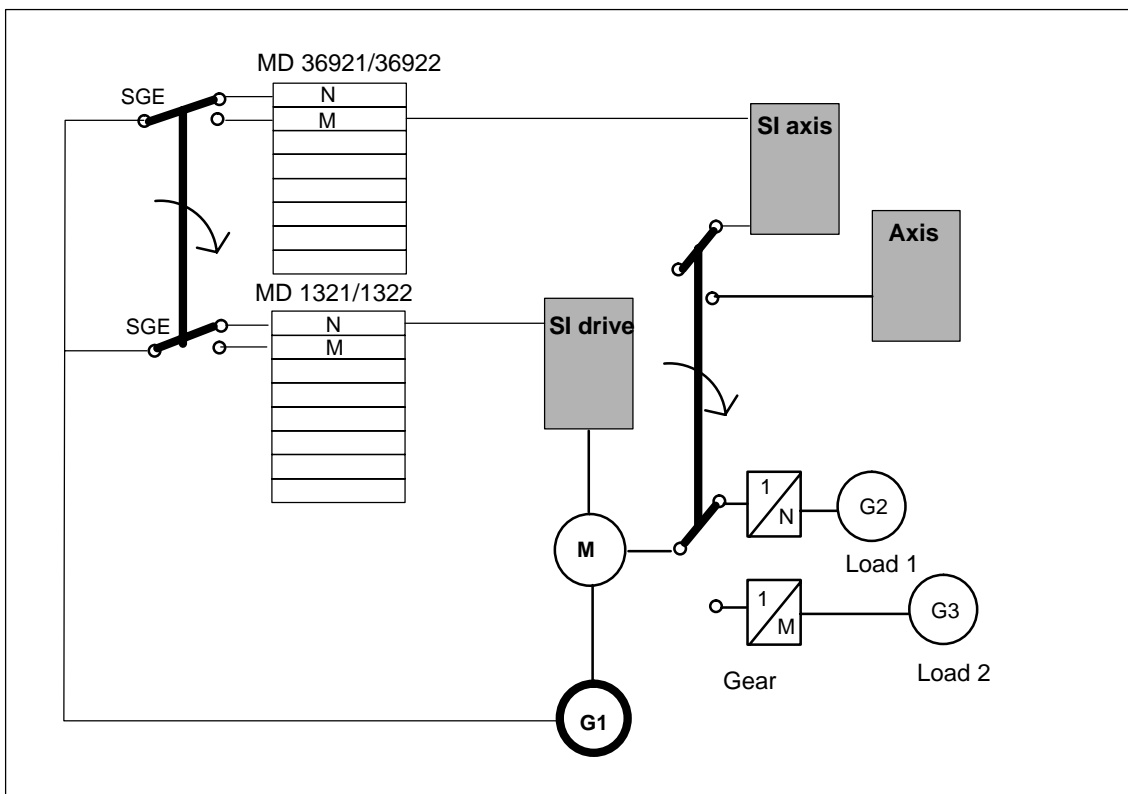

Fig. 9-2 SG/gearbox stage changeover

The SGEs to change over the gearbox stage must be safety-related and therefore be able to be controlled through 2 channels. Channel 1 should evaluate the feedback signals from the gearboxes, channel 2 should evaluate the feedback from the setpoint changeover DB3x.DBX96.5 "Check of drive accepted". It is not permissible to use a 1-channel signal source to control the SGEs.

2-encoder system

If the SI axis has two encoders, when changing over to the non-SI axes, it is not permissible that the second safety encoder is de-coupled. Both SI encoders must be continuously used. The gearbox ratio between the SI axis and the non-SI axes must be taken into account when configuring the SI gearbox ratios.

STOPS

The setting MD 36964: SAFE_IPO_STOP_GROUP \neq 0 is not permissible for the SI axis, as this causes the interpolating relationships to be cancelled.

Brake test

The brake test can only be carried-out in the SI axis. The SI axis must have the drive checking function for the brake test

9.3 Measuring system changeover

Acceptance test

The acceptance test for non-SI axes must be manually carried-out and logged.
The acceptance test does not provide any support.

9.3 Measuring system changeover

Measuring system changeover on 840D

When measuring systems are changed-over (selected) via interface signals
"Position measuring system 1" (DB 31..., DBX1.5)
"Position measuring system 2" (DB 31..., DBX1.6) the following applies:

The encoder used by the position controller is changed-over.

Note

SI continues to work with the configured encoder.

9.4 Gantry axes

Stop responses Stop A, B, C for gantry axes are initiated as fast as possible for all of the axes in the group. However, if unacceptable offsets result because of the differing braking behavior of the axes, then stop response Stop D should be configured.

Note

The user must ensure that terminal 663 is controlled simultaneously for all drive modules in a single gantry group.

9.5 Vertical axis

The machine manufacturer must take various measures (refer to Chapter 3.5, "System prerequisites") to prevent vertical axes from falling when the safe standstill function is activated (e.g. after STOP B/A). This means that the mechanical brake must be controlled as quickly as possible.

From SW 6.3.21, a function check of the mechanical braking system can be carried-out for all axes that must be held using a holding brake to prevent movement in the open-loop controlled mode (refer to Chapter 10.9).

9.6 Parking axis

The pulse enable command must be cancelled before the park state is activated (using the interface signal "Park"). The pulse enable signal may not be applied again until the park state has been de-selected.

This can be done by means of the NCK-SGE "Test stop selection" (the message "Test stop active" is then displayed). If the SPL is used, the pulses should be cancelled by selecting external stop A (corresponds to "Safe standstill").

Parking an axis with absolute reference

When the "parking" function is selected, actual value acquisition and the position measuring system monitoring are de-activated for an axis/spindle. The NCK actual value is frozen and mechanical actual value changes are no longer detected. This also applies to the actual value acquisition of the two safety monitoring channels NCK and 611digital.

The absolute reference of an axis can therefore no longer be reliably detected. The safety monitoring channels respond as follows:

- Alarms 27000/300950 are displayed "Axis no longer safely referenced"
- SGA "Axis safely referenced" cancelled on NCK and drive side

The user can align the actual value acquisition of the safety monitoring channels by referencing/synchronizing to the the machine position. These alarms are only displayed for axes for which safety monitoring functions with absolute reference are activated, i.e. for SE and SN. Alarms are not displayed for axes that do not have these monitoring functions.

Machine data SAFE_PARK_ALARM_SUPPRESS can be used to suppress Alarms 27000/300950.

9.7 OEM applications

Information for HMI–OEM users

If SINUMERIK Safety Integrated) (SI) and OEM applications (for HMI) are used at the same time, the following points must be observed.



Important

1. The PLC interface signals (DB31, ...) with safety–related drive inputs and outputs may not be written into using the variable service (utility) of the NCDDE server.
 2. Write machine data using variable service
An acceptance test must be carried if the SI machine data were changed using the variable service of the NCDDE server.
 3. Changing alarm priorities
The alarm priorities selected for SI must be retained.
 4. Changing alarm tests
The alarm texts of the SI alarms can be modified: This must be clearly documented for the user.
 5. Carry–out "acceptance test" message box
The "carry–out acceptance test" may not be modified!
 6. User agreement
Functions relating to the user agreement (e.g. call, protective mechanism) may not be altered.
-

Information for NCK–OEM users

SINUMERIK Safety Integrated can also be used for NCK–OEM applications.

Note

System memory change
System memory changes caused by the OEM application result in Alarm 27003 "Checksum error occurred".

9.8 Overtemperature

Response to an overtemperature

It must be ensured that overtemperatures in the Sinumerik/Simodrive group do not result in subsequent malfunctions – that in turn can cause safety-critical situations. Especially if the overtemperature condition simultaneously affects both monitoring channels (e.g. when the ambient temperature increases), the temperature alarm signals that are present must be evaluated in order to initiate a safety-related response in plenty of time.

The following temperature monitoring functions are active and can be evaluated for the subsequent response.

Temperature monitoring NCK

When the associated temperature monitoring function responds, this is flagged by the interface signal DB10.DBX109.6 "Air-temperature alarm". When the interface signal is set, this is in conjunction with NCK Alarm 2110 "NCK temperature alarm" or Alarm 2120 "NCK fan alarm".

If the temperature or fan monitoring responds, then it is sufficient if the PLC initiates the appropriate measures; it is not absolutely necessary that the measures are initiated using SPL logic.

Safety related response required:

- All safety-related outputs (SGAs) should be brought into the safe state (logical "0") as a result of the response.
- The drives should be brought to a standstill and the pulses then cancelled.
- The response does not have to be initiated immediately, i.e. before the SGA shutdown is triggered and the pulses can be cancelled, machine-specific measures configured in the application can be initiated. This can include, e.g. an NC stop or similar. The two mentioned measures are required at the end of the sequence of responses.
- It may make sense to derive an Emergency Stop request from the interface signal.

Temperature monitoring, drive, motor temperature

When the associated temperature monitoring responds, this is indicated using the axial interface signals DB<axis>.DBX94.0 "Motor-temperature pre-alarm". When the interface signal is set, this is associated with drive Alarm 300614 "Axis %1 Drive %2 time monitoring, motor temperature". It is not absolutely necessary to evaluate this signal as an appropriate response can be already activated using the associated machine data.

If required, an evaluation can also be made as part of the SI functionality.

9.8 Overtemperature

Temperature monitoring, drive, heatsink temperature

When the associated temperature monitoring responds, this is indicated using the axial interface signals DB<axis>.DBX94.1 "Heatsink temperature". When the interface signal is set, this is in conjunction with drive Alarm 300515 "Axis %1 Drive %2 heatsink temperature power module exceeded". It is not absolutely necessary to evaluate this signal as an appropriate response can be already activated using the associated machine data.

If required, an evaluation can also be made as part of the SI functionality.

9.9 Behavior of Safety Integrated when the drive bus fails

When the drive bus fails, then communications between the drive and NCK required for SI also fail. The pulses are immediately cancelled from both channels. This pulse cancellation must be delayed for a short time so that in this particular fault situation, a drive-based response (i.e. integrated in the drive) (ESR) can be carried-out at the machine.

Reference: Programming Manual Workshop Planning (PGA)

This is the reason that after a bus failure has been detected, there must be a delay before canceling the pulses both in the NCK monitoring channel and in the drive monitoring channel. The selected axial SI functionality (SG, SE, SBH) at the instant that the drive bus fails, is still available through one channel in the drive monitoring channel. The NCK monitoring channel can no longer be monitored as there is no actual value.

The PLC SPL remains functional in the scope in which the drive monitoring channel is not required. From the PLC-SPL it is not possible to select another monitoring function or immediately cancel the pulses via an external Stop A.

The NCK-SPL also remains functional if it does not receive its input quantities (\$A_INSE) from the DMP modules connected to the drive bus – but instead via PROFIsafe I/O or the local inputs on the NCU. If another axial monitoring function (e.g. SE stage changeover) is selected, this remains ineffective as the axial NCK monitoring functions are de-activated. However, when an external STOP A is selected, this results in the pulses being immediately cancelled via terminal 663 – just the same as for an SBH selection. An SG changeover can also result in immediate pulse cancellation.

If the NCK-SGA "enable pulses" is not output via the local outputs on the NCU, but via the DMP modules on the drive bus, then it is not possible to delay the pulse cancellation via terminal 663. The DMP modules delete their outputs when a drive bus failure is detected.

If the internal pulse cancellation (also refer to Section 3.1.2 "Shutdown paths") is used, then the SGA "externally enable pulses" must be connected to terminal 663. It is no longer possible to internally cancel the pulses via the drive bus. In this case, the SGA "externally enable pulses" must be output via the local outputs on the NCU.

Activating

The delay time up to pulse cancellation via terminal 663 must be parameterized for a value greater than 0 in the NCK machine data 10089 \$MN_SAFE_PULSE_DIS_TIME_BUSFAIL and in the appropriate drive machine data 1380 MD_SAFE_PULSE_DISABLE_TIME_FAIL. For a standard value of 0, the function is de-activated; when the drive bus fails, the pulse enable signal for terminal 663 is immediately withdrawn.

9.9 Behavior of Safety Integrated when the drive bus fails

9.9.1 Behavior of the axial NCK monitoring channel

If a delayed pulse cancellation is parameterized using MD \$MN_SAFE_PULSE_DIS_TIME_BUSFAIL, after a bus failure, the SGA leave all of the axial SI monitoring channels in their old condition. After this delay time has expired, all SGA are, as before, deleted. The axial monitoring functions are no longer processed immediately after the bus fails as the basis for the monitoring function – the safe actual value – is no longer available.

In the following cases, when the drive bus fails, the pulses are immediately cancelled via terminal 663 – even if a delay time is parameterized using \$MN_SAFE_PULSE_DIS_TIME_BUSFAIL.

- An external STOP A is selected.
- A test stop or an external pulse cancellation test is selected.
- The SBH function is or will be selected.
- An SG stage is selected or will be selected, for which it was previously defined, that in this SG stage, no ESR will be executed when the drive bus fails (e.g. SG stage for personnel protection). This definition is made in MD 36963 \$MA_SAFE_VELO_STOP_REACTION (for the individual SG stages) or MD 36961 \$MA_SAFE_VELO_STOP_MODE (for all SG stages together)

9.9.2 Behavior without NCK–SPL

Without NCK–SPL, the axial NCK–SGA are directly transferred to the output modules. The SGA that are output indicate the monitoring status at the instant in time that the drive bus failed. After this delay time has expired, all NCK–SGA are set to 0. However, this only applies to SGA that are output via the local outputs on the NCU. The DMP modules on the drive bus immediately set their outputs to 0 when the bus fails.

The axial SGE are still read–in if they are not supplied from the DMP modules on the drive bus. This means, for example, that an immediate pulse cancellation can be triggered (e.g. by selecting SBH). The images of the SGE from the DMP modules on the drive bus are left at their old values.

9.9.3 Behavior with NCK–SPL

The NCK–SPL remains active as the actual value is not required for the SPL. This means, for example, that an Emergency Stop still results in an external STOP A and therefore pulse cancellation, even if the delay time after the drive bus failed has still not expired.

In order to correctly process NCK–SPL, the input and output quantities of the SPL must be considered in more detail (\$A_INSE, \$A_OUTSE, \$A_OUTSI).

\$A_INSE

The system variables \$A_INSE contain the input circuit of the NCK–SPL. If these input quantities are received from local inputs on the NCU – or PROFIsafe – then no other measures have to be made.

However, if these input quantities come from the DMP modules on the drive bus, then the last valid image of the input circuit is used. Otherwise, with the fail–safe value of 0, an external STOP A would be immediately initiated which, in turn, results in immediate pulse cancellation.

Example:

For an Emergency Stop, a STOP A is immediately initiated. This means that the time up until the pulses are cancelled is extremely short. If the input required is read–in from the DMP modules on the drive bus, then the response time for an Emergency Stop – that almost always occurs simultaneously with a bus failure – increases by the time specified in \$MN_SAFE_PULSE_DIS_TIME_BUSFAIL. The pulses are only cancelled after this time and the initiated Emergency Stop is not recognized. This is the reason that \$MN_SAFE_PULSE_DIS_TIME_BUSFAIL must be selected to be relatively short. In situations such as these, we recommend that the local inputs on the NCU or PROFIsafe are used.

When DMP modules are used on the drive bus with local inputs on the NCU or F–DI modules with PROFIsafe (mixed mode), the engineer programming the SPL must take into account this different behavior if he wishes to configure a delayed pulse cancellation when the drive bus fails.

\$A_OUTSE

The \$A_OUTSE system variables include the outputs of the NCK–SPL, that should be output to the peripherals. The output(s) to terminal 663 of the terminal module must be output via the local outputs on the NCU. Under no circumstances may these outputs be output via the DMP modules connected to the drive bus as this would result in immediate pulse cancellation if the drive bus was to fail.

\$A_INSI

\$A_INSI is the input interface to the axial NCK monitoring functions. This means that it includes the NCK–SGA. The NCK–SGA are left in their old state so that when the drive bus fails, no further action is required here.

\$A_OUTSI

\$A_OUTSI is the output interface to the axial NCK monitoring functions. This means that it includes the NCK–SGE. In this interface, only the SGE "de-selection of the external STOP A", "SBH selection" and the selection of an SG stage for personnel protection are relevant (also refer to "behavior of the axial NCK monitoring channel"). The reason for this is that the actual axial monitoring functions are no longer active:

- An external stop with low priority cannot be executed as setpoints cannot be transferred to the drive.
- The additional axial NCK monitoring functions require the actual value that is no longer available.

9.9.4 Behavior of the drive monitoring channel

The drive monitoring channel, just like the NCK monitoring channel, delays its pulse cancellation by the parameterized time. However, in addition, it keeps the monitoring functions active that were active at the instant of the failure. The drive can still monitor as it still has access to the correct actual value.

In the following cases, when the drive bus fails, the pulses are immediately cancelled – even if a delay time has been parameterized:

- The SBH function is selected.
- An SG stage has been selected where it has been previously defined, that in this SG stage, no ESR will be executed when the drive bus fails (e.g. SG stage for personnel protection).

9.9.5 SGE/SGA processing in the PLC

The SGE/SGA processing in the PLC must always be available in order to logically combine the 611digital SGA and to output this to the periphery or read-in the peripheral signals and distribute these to the 611digital SGE.

Without NCK–SPL, they correspond to the assignment of the SGA/SGE to the digital input/output modules that is made in the NCK using the appropriate machine data.

With NCK–SPL, the PLC–SPL is the 2nd channel of the SPL; the results are compared between the NCK and PLC.

The SGE that are read-in are not effective as they cannot be transferred to the 611digital monitoring channel via the faulted drive bus.

When processing the SGA in the PLC, the 611digital SGA are left in the same state as before the drive bus failed.

9.9 Behavior of Safety Integrated when the drive bus fails

Due to the missing sign-of-life character in the SGE/SGA data transfer, the PLC will detect a fault at the latest after 2 s. However, at this instant in time, the pulses would already have been cancelled after the expiration of \$MN_SAFE_PULSE_DIS_TIME_BUSFAIL or the appropriate drive machine data.

9.9.6 Limitations/constraints

An ESR executed autonomously in the drive when the drive bus fails is only possible if the pulse enable is output at terminal 663 using the local outputs on the NCU. The DMP modules themselves are connected to the same drive bus and when the drive bus fails they automatically clear (delete) their outputs.

When using the NCK-SPL, the input quantities of the SPL should also come from the local inputs on the NCU and/or from the PROFIsafe I/O. The reason for this is that the input quantities of the DMP modules remain at the same state at the instant that the bus failed. If an Emergency Stop is implemented using SPL, when considering the maximum response time up to pulse cancellation, the delay time in \$MN_SAFE_PULSE_DIS_TIME_BUSFAIL must be taken into account.

As soon as ESR has been enabled, each time that the drive bus fails, it must be assumed that the axis to be retracted moves. The emergency retraction is initiated in the position control clock cycle – the Safety Integrated monitoring functions are realized in the monitoring clock cycle. The pulse cancellation initiated by Safety Integrated can only prevent an emergency retraction if the monitoring clock cycle has been parameterized exactly the same as the position controller clock cycle.

9.9.7 Examples

Example 1

The following parameterization ensures that when the drive bus fails there is 200 ms time for an ESR – executed autonomously in the drive – before the pulses are cancelled. The SG stages for personnel protection are defined differently in the individual axes.

```
$MN_SAFE_PULSE_DIS_TIME_BUSFAIL = 0.2
```

```
; Parameterization for the X axis (AX1)
```

```
; pulses are immediately cancelled in all SG stages, STOP D is initiated when  
; an SG is exceeded
```

```
$MA_SAFE_VELO_STOP_MODE[AX1] = 3
```

```
; Parameterization for the Y axis (AX2)
```

9.9 Behavior of Safety Integrated when the drive bus fails

; pulses are not immediately cancelled in all SG stages, STOP D is initiated
 ; when an SG is exceeded

; Parameterization for the Z axis (AX3)

; in all SG stages, the pulses are immediately cancelled, STOP D is initiated
 ; when an SG is exceeded in SG stages 1 and 2, STOP C in SG stages 3 and 4

\$MA_SAFE_VELO_STOP_MODE[AX3] = 5; =>
 \$MA_SAFE_VELO_STOP_REACTION becomes effective
 \$MA_SAFE_VELO_STOP_REACTION[0, AX3] = 3 ; SG stage 1
 \$MA_SAFE_VELO_STOP_REACTION[1, AX3] = 3 ; SG stage 2
 \$MA_SAFE_VELO_STOP_REACTION[2, AX3] = 2 ; SG stage 3
 \$MA_SAFE_VELO_STOP_REACTION[3, AX3] = 2 ; SG stage 4

; Parameterization for the A axis (AX4)

; in all SG stages, the pulses are not immediately cancelled, STOP D is
 ; initiated when an SG is exceeded in SG stages 1 and 2, STOP C in SG
 ; stages 3 and 4

\$MA_SAFE_VELO_STOP_MODE[AX4] = 5; =>
 \$MA_SAFE_VELO_STOP_REACTION becomes effective
 \$MA_SAFE_VELO_STOP_REACTION[0, AX4] = 13 ; SG stage 1
 \$MA_SAFE_VELO_STOP_REACTION[1, AX4] = 13 ; SG stage 2
 \$MA_SAFE_VELO_STOP_REACTION[2, AX4] = 12 ; SG stage 3
 \$MA_SAFE_VELO_STOP_REACTION[3, AX4] = 12 ; SG stage 4

; Parameterization for the B axis (AX5)

; the pulses are only immediately cancelled in SG stages 1 and 3, STOP D is
 ; initiated when an SG is exceeded in all stages

\$MA_SAFE_VELO_STOP_MODE[AX5] = 5; =>
 \$MA_SAFE_VELO_STOP_REACTION becomes effective
 \$MA_SAFE_VELO_STOP_REACTION[0, AX5] = 3 ; SG stage 1
 \$MA_SAFE_VELO_STOP_REACTION[1, AX5] = 13 ; SG stage 2
 \$MA_SAFE_VELO_STOP_REACTION[2, AX5] = 3 ; SG stage 3
 \$MA_SAFE_VELO_STOP_REACTION[3, AX5] = 13 ; SG stage 4

; Parameterization for the C axis (AX6)

; immediate pulse cancellation only in SG stages 1 and 3, STOP D is initiated
 ; when an SG is exceeded in SG stages 1 and 2, STOP C in SG stage 3 and
 ; STOP E in SG stage 4

\$MA_SAFE_VELO_STOP_MODE[AX6] = 5; =>
 \$MA_SAFE_VELO_STOP_REACTION becomes effective
 \$MA_SAFE_VELO_STOP_REACTION[0, AX6] = 3 ; SG stage 1
 \$MA_SAFE_VELO_STOP_REACTION[1, AX6] = 13 ; SG stage 2
 \$MA_SAFE_VELO_STOP_REACTION[2, AX6] = 2 ; SG stage 3
 \$MA_SAFE_VELO_STOP_REACTION[3, AX6] = 14 ; SG stage 4

Example 2

The following example clearly indicates the problems when grouping axes whose terminal 663 is controlled using a digital output:

The 3 axes – X, Y and Z – have the same parameterized behavior in their SG stages when the drive bus fails: For SG1, the pulses should be immediately canceled with the drive bus fails, however, for SG2 to SG4, with a delay. Terminal 663 is controlled from all 3 drives via the same output (local output on the NCU). When the bus fails, a 500 ms delay should first expire before the pulses are cancelled. This is parameterized as follows:

```
$MN_SAFE_PULSE_DIS_TIME_BUSFAIL = 0.5
```

```
; Parameterization for the X axis (AX1):
```

```
; STOP D is initiated when an SG is exceeded in SG stages 1 and 2, STOP C
; in SG stages 3 and 4
```

```
$MA_SAFE_VELO_STOP_MODE[AX1] = 5; =>
$MA_SAFE_VELO_STOP_REACTION becomes effective
$MA_SAFE_VELO_STOP_REACTION[0, AX1] = 3 ; SG stage 1
$MA_SAFE_VELO_STOP_REACTION[1, AX1] = 13 ; SG stage 2
$MA_SAFE_VELO_STOP_REACTION[2, AX1] = 12 ; SG stage 3
$MA_SAFE_VELO_STOP_REACTION[3, AX1] = 12 ; SG stage 4
```

```
; Parameterization for the Y axis (AX2):
```

```
; STOP C is initiated when an SG is exceeded in SG stage 1, STOP E in SG
; stages 2, 3 and 4
```

```
$MA_SAFE_VELO_STOP_MODE[AX2] = 5; =>
$MA_SAFE_VELO_STOP_REACTION becomes effective
$MA_SAFE_VELO_STOP_REACTION[0, AX2] = 2 ; SG stage 1
$MA_SAFE_VELO_STOP_REACTION[1, AX2] = 14 ; SG stage 2
$MA_SAFE_VELO_STOP_REACTION[2, AX2] = 14 ; SG stage 3
$MA_SAFE_VELO_STOP_REACTION[3, AX2] = 14 ; SG stage 4
```

```
; Parameterization for the Z axis (AX3):
```

```
; STOP D is initiated when an SG is exceeded in SG stage 1, STOP E in SG
; stages 2, 3 and 4
```

```
$MA_SAFE_VELO_STOP_MODE[AX3] = 5; =>
$MA_SAFE_VELO_STOP_REACTION becomes effective
$MA_SAFE_VELO_STOP_REACTION[0, AX3] = 3 ; SG stage 1
$MA_SAFE_VELO_STOP_REACTION[1, AX3] = 14 ; SG stage 2
$MA_SAFE_VELO_STOP_REACTION[2, AX3] = 14 ; SG stage 3
$MA_SAFE_VELO_STOP_REACTION[3, AX3] = 14 ; SG stage 4
```

This results in the following behavior when the drive bus fails:

1. If SG1 is selected in any one of the three axes at the instant that the bus fails, then the pulses are immediately cancelled for all 3 axes. This is because

9.9 Behavior of Safety Integrated when the drive bus fails

terminal 663 is controlled from all 3 axes via one output and the pulses are immediately cancelled from the axis with SG1 via this output.

2. If one of the SG stages 2 to 4 is selected in all three axes, then pulse cancellation is delayed for 500 ms.

The examples listed below are intended to provide support when engineering and using Safety Integrated. They are recommended solutions for applications that are frequently encountered in the field and for which there is no clear or trivial solution. The examples are intended purely as an aid to configuration and should not be interpreted as configuration instructions, i.e. equally suitable alternative solutions may exist.

10.1 General information on engineering

Please refer to the information in the following references for instructions on how to connect the SINUMERIK 840D control system to the SIMODRIVE 611 digital drive system:

References for SINUMERIK 840D

/HBD/, NCU Manual
/IAD/, Commissioning Manual
/LIS/, Lists

References for SIMODRIVE 611

/PJ1/, SIMODRIVE 611, Configuration Manual for Inverters
/PJ2/, SIMODRIVE, Configuration Manual for AC Motors

Note

Please note that the possibilities of connecting-up the NE unit are not restricted in any way by SI. For example, three-wire or six-wire line supply configurations, star-delta operation and operation when the power fails can still be implemented as before.

Engineering

The system can be configured in the following basic ways:

- Safety Integrated without safe programmable logic
- Safety Integrated with safe programmable logic (SPL) without contactless Emergency Stop
- Safety Integrated with safe programmable logic (SPL) and contactless Emergency Stop

Safety Integrated without SPL

The Emergency Stop circuit and door monitoring (for limitations, refer to Chapter 10.3.7 "Protective door locking") must be implemented conventionally with safety relays. Switches and sensors are interconnected on the PLC side using the S7 program – and on the NCK side by connecting–up contactors, switches and sensors. The NC logic and PLC logic must be identical.

Safety Integrated with SPL and without contactless Emergency Stop

If SPL is used without contactless Emergency Stop, the SPL is exclusively used for logically combining safety–related input and output signals. The Emergency Stop circuit and the connection of the infeed/regenerative feedback module have to be implemented in the same way as for Safety Integrated without SPL.

Safety Integrated with SPL and contactless Emergency Stop

If SPL is used, emulation of S7 logic using contactors and therefore the wiring is no longer necessary. The safe programmable logic is programmed on the PLC side in the form of an S7 program and on the NCK side by using an ASUB. A contactless Emergency Stop function can be implemented with the external stop function and the SPL. This means that safety relays are not required for the Emergency Stop area. The door switch can also be monitored by the SPL – in this case, the safety switching devices (e.g. safety relays) are also not required.

Note

The engineering examples described here do not use the latest status of the safety functions available. When engineering new systems with current software versions, functions can be utilized for simplification. Below is a list of the essential expanded functionality:

1. Setpoint speed limiting (refer to Chapter 9.1)
 2. Starting the NCK–SPL using PROG_EVENT mechanism (refer to Chapter 5.10.2)
 3. Safety software relay (refer to Chapter 5.10.6)
 4. Direct communications between the NCK and PLC–SPL (refer to Chapter 5.10.10)
 5. Simplified wiring of shutdown paths using internal signal feedback and internal pulse cancellation (refer to Chapter 5.1.2/5.1.3)
-

10.2 Circuit examples

A machine tool with 2 axes and one spindle has been selected as an example.

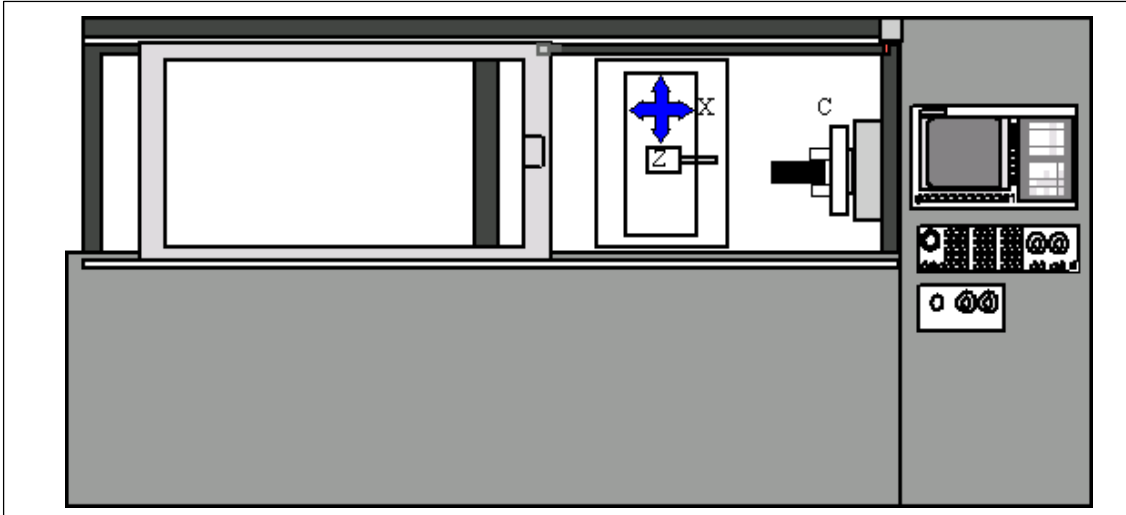

Fig. 10-1 Schematic diagram of a machine

The following must be taken into account before the machine is configured:

- What is the magnitude of the potential hazard?
- Which measures can be implemented to reduce the risk?
- What residual risks remain?
- Which safety functions should be implemented?

General information

The circuit shown below is an example of a drive with an incremental measuring system. It is provided to illustrate the principle of how a safety zone on a machine can be monitored.

The following functions are implemented with Safety Integrated in the example:

- Contactless Emergency Stop
- When the protective door is open, the operator can select either safe operating stop or traverse with a safely-reduced speed at 2 m/min (axes) and 50 RPM (spindle) using the key-operated switch.
- When the protective door is closed, Safety Integrated monitors all of the drives for maximum speed
- The shutdown paths are tested (with SPL: Testing the external STOPs and forced checking procedure of the inputs and outputs).

This means Safety Integrated with SPL with contactless Emergency Stop

10.2 Circuit examples

Note

- The basic circuit must be adapted to the various safety zones (if applicable) and the number of axes according to the machine configuration.
- SI functions are used to safely monitor the drives for standstill or a specific speed and to stop them safely in the event of a fault/error.

10.2.1 Control and drive components

The configuration of the individual components is illustrated below.

The system requirements are described in the Description of Functions.

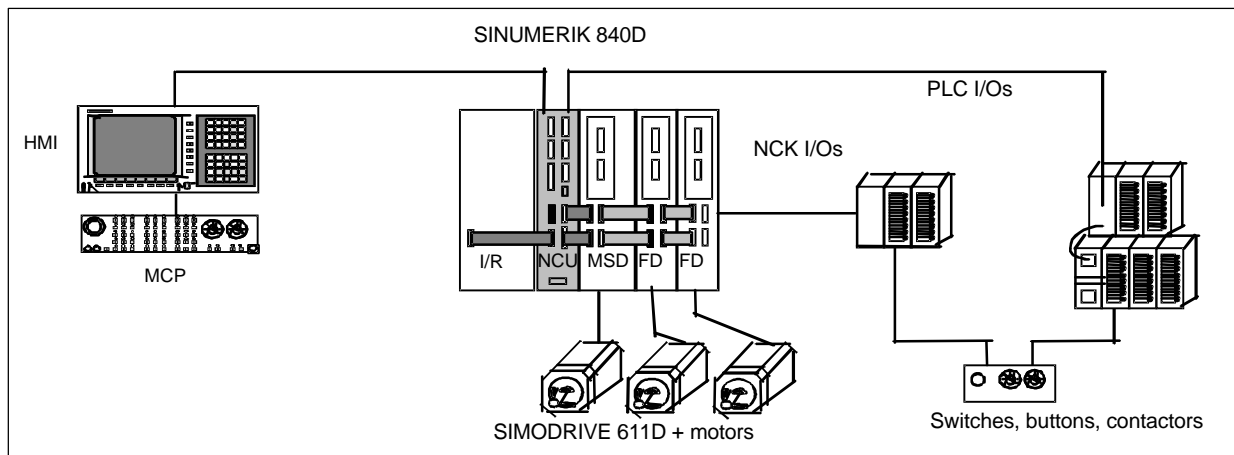

Fig. 10-2 Structure of the control and drive components

Description

The HMI Advanced, NCU572 and SIMODRIVE 611digital components are used in this example. The design must also be expanded to include a terminal block with 16-bit I/O modules for the NCK side and additional S7 modules for the PLC/drive side.

The additional operating elements (switches, buttons etc.) and the contactors required for disconnecting the power are listed and described in more detail in the relevant chapters.

The drive configuration is shown in the following table:

Slot	Drive number	Active	Drive	Module
2	1	yes	FD	2-axis-1
3	2	yes	FD	2-axis-2
1	3	yes	MSD	1-axis
4	4	yes	PER	

Terminal block

The 16-bit DMP modules used are located in the following slots in the terminal block:

16-bit input module	Slot 1
16-bit output module	Slot 2

10.2.2 Engineering

Objective

In order to achieve the functional safety of a machine or plant, it is necessary that the safety-related parts of the protection and control devices function correctly. And not only this, when faults develop, they must behave so that either the plant remains in a safe state or it is brought into a safe state. In this case, it is necessary to use specially qualified technology that fulfills the requirements described in the associated Standards.

"SINUMERIK Safety Integrated" is one aspect of this qualified technology (certified, e.g. to EN 954-1) and must be integrated in the machine in such a way that functional safety is achieved in conjunction with the other protective equipment of the machine/system (e.g. protective doors, Emergency Stop buttons,...).

The aim of this configuration is to describe the machine-specific combination of "SINUMERIK Safety Integrated[®]" and other protective equipment.

Sequence

When engineering the SI system, the machine functions are sub-divided into different operating modes (these operating modes are initially independent of the NC operating mode – the relevant combinations must be configured). The safety functions that are to be activated when the protective doors are opened and closed are then defined for these modes.

The two operating modes – setting-up and production – are used in the machine example. For an Emergency Stop, the drives of the complete drive group are brought to a standstill using the external stop functions (Stop C → Stop A).

10.2 Circuit examples

Defining the operating modes

The required safety functions are defined for the machine operating modes.

The machine operating mode (setting-up/production) is selected using a key-operated switch. Production is the default machine operating mode. Usually, the key-operated switch can only be actuated by authorized personnel. This means that only appropriate trained personnel can move the machine when the protective door is open.

Setting-up with the protective door open

- Safely-reduced speed (SG1) →
(typical values)

Spindle	Axes
2 m/min	50 RPM
- The axes and spindles must stop when the door is opened, or the speed of the axis/spindle must be < SG1 (this must be ensured by the PLC user program).
- The PLC program interlocks (inhibits) the NC modes MDA and AUTO

Setting-up with the protective door closed

- Safely-reduced speed (SG2) →
(typical values)
(the drives are monitored for maximum speed).

Spindle	Axes
10 m/min	2000 RPM
- When the door is closed, Safety Integrated automatically changes-over to the SG2 limit.
- All NC operating modes are permitted when the protective door is closed

Production with the protective door open

- The NC operating modes MDA and AUTO are disabled by the PLC program – the automatic mode is not permitted when the protective door is open. The safety function safe operating stop (SBH) is activated with the key-operated switch position "Production" when the protective door is open. This means that the drive is monitored for zero speed.
- The axes and the spindle must stop when the protective door is opened (this must be ensured by the PLC user program)

10.3 Safety Integrated with SPL

10.3 Safety Integrated with SPL

Description

The principle method of operation is illustrated in the diagram below. Please refer to this diagram when reading the following chapters.

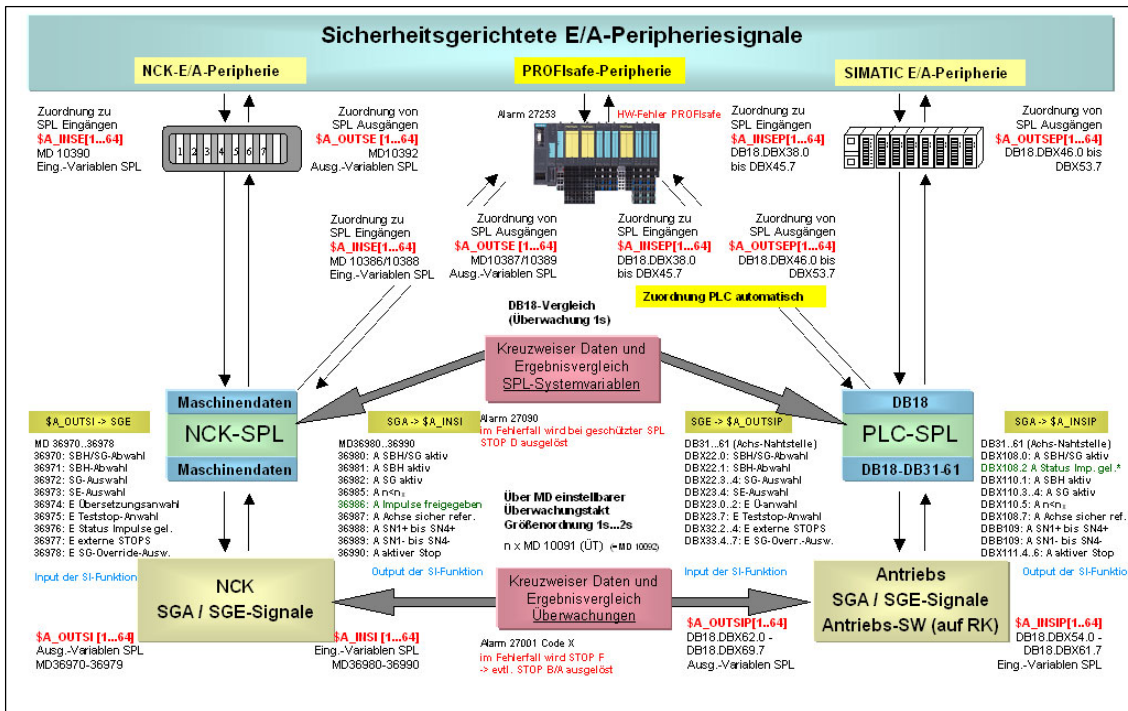

Fig. 10-3 Function chart – a detailed view of this diagram is provided in the Attachment (10.3.12)

Note

Examples of the PLC blocks can be requested from the Centre of Competence Service (CoCS) – Sinumerik Safety Integrated.

Typical blocks for SI applications

The PLC blocks, listed in Chapter 7 are available as example in the toolbox for the basic PLC program. Further, an S7 library can be requested via Customer Support (refer to A.1) as part of the Hotline service. This S7 library has typical blocks for the SI application that can be generally used. They can be incorporated in a specific project and adapted to the particular requirements by appropriately parameterizing them.

Description

In this example, PLC blocks FC95 (start ASUB), FC96 (PLC–SPL), FC97 (safety test routine) are used for Safety Integrated.

The basic program blocks FB4 and FC9 are called (FB1/P3) in FC 95 to start the NCK–ASUB. The parameter assignment for FC9 and FB4 is stored in DB120.

Program

Program excerpt DB120 :

```

DATA_BLOCK DB 120
TITLE =
VERSION : 0.1

STRUCT
  pname : STRING [32 ]      := '_N_SAFE_SPF'    ;//Program name
  ppath : STRING [32 ]     := '/_N_CST_DIR/'    ;//Directory
  FB4_Error : BOOL         ;//Error bit
  FB4_Done : BOOL          ;//Request completed
  FB_State : WORD          ;//Cause of error
  FC9_Activ : BOOL         ;//ASUB active
  FC9_Done : BOOL         ;//ASUB completed
  FC9_Error : BOOL        ;//Error when proces-
                          ;//sing the request
  FC9_SError : BOOL       ;//Interrupt number
                          ;//not assigned
  FC9_Ref : WORD          ;//For internal use
END_STRUCT ;

BEGIN
  pname := '_N_SAFE_SPF';
  ppath := '/_N_CST_DIR/';
  FB4_Error := FALSE;
  FB4_Done := FALSE;
  FB4_State := W#16#0;
  FC9_Activ := FALSE;
  FC9_Done := FALSE;
  FC9_Error := FALSE;
  FC9_SError := FALSE;
  FC9_Ref := W#16#0;
END_DATA_BLOCK

```

After the NCK–SPL has been successfully started by the PLC (FC95) processing of the PLC–SPL (FC96) is enabled in OB1.

Two more pre–defined blocks are integrated in FC97 – FC60 (typical blocks can be requested from the Hotline, Telephone No. 0180–525 8000) and FC21 (basic program block – FB1/P3). Modifications must also be made to OB100 to ensure perfect operation of the safe programmable logic.

10.3 Safety Integrated with SPL

The markers, outputs and inputs used in this example have been freely selected according to the test set-up being used.

Chapter 10.3.3 provides an overview of the I/O (peripherals) and variables used.

The ASUB for the NCK-SPL must be saved in the standard cycle directory (CST.DIR) under the name SAFE.SPF.

The Safety Integrated functions SBH/SG and the SI function "External STOPs" are activated for the individual drives. External stops are a prerequisite for using the SPL logic.

X axis	36901 SAFE_FUNCTION_ENABLE	41H
Z axis	36901 SAFE_FUNCTION_ENABLE	41H
Spindle	36901 SAFE_FUNCTION_ENABLE	41H

The following machine data must either be set or checked to ensure error-free start-up of the NCK-SPL.

11602 ASUP_START_MASK	7H
11604 ASUP_START_PRIO_LEVEL	1H

10.3.1 Starting configuration in the OB100

Description

A marker (M210.0) is set in FC 95 in OB100 to start the NCK-ASUB. This marker also inhibits initialization of the PLC-SPL (FC96) in OB1 until the NCK-SPL has started.

The PLC outputs that are used for the forced-checking procedure of the inputs and outputs must be set to "1".

It is no longer necessary to pre-assign the INSIP variables in the DB18. Parameterization of machine data 10095 SAFE_MODE_MASK = "0" (default setting) ensures that all SGAs of the NCK channel are automatically set to "0", and also the INSI variables (if SPL is used).

Any NC alarm can prevent ASUB SAFE.SPF from starting up. They must be cancelled when the system is running-up. For example, in the program excerpt, the Emergency Stop alarm is cancelled during run-up.

Program

OB100 program excerpt:

```
// Set ASUB_start_marker and forced checking procedure
// output/reset alarms (e.g. EMERGENCY STOP)
//
SET

S   M           210.0    // NCK-ASUB Start
S   A           88.1     // Supply EMERGENCY STOP
R   DB10.DBX56.1      // De-activate EMERGENCY STOP (PLC)
R   DB21.DBX21.7     // De-activate single block
//

// Pre-assignment (default) of SGE
//
L   0                // Logical "0"
T   DB31.DBW22       // SGE axis X
T   DB32.DBW22       // SGE axis Z
T   DB33.DBW22       // SGE spindle C
T   DB31.DBW32       // SGE axis X
T   DB32.DBW32       // SGE axis Z
T   DB33.DBW32       // SGE spindle C
```

Description

The bits in the axis/spindle data blocks are not cleared when the system runs-up (only valid up to SW 5 – from SW 5 onwards, the bits in the axis/spindle data block are cleared when the system runs-up). The supply of values to the NCK-SGE is however slightly delayed by the NCK-SPL running-up so that the crosswise data comparison of the SGE signals can respond. This is the reason that the SGEs on the PLC side must be pre-assigned a value of "0".

Correspondingly, if NCK-SGE is permanently de-selected by the axis-specific machine data (80000000H), the PLC-SGE must also be pre-assigned or directly supplied from the PLC when the system runs-up.

Example: SBH is permanently de-selected → safely-reduced speed is active

1. Drive:

36971: SAFE_SS_DISABLE_INPUT 80000000H

→ set DB31.DBX22.1 to "1" when the system runs-up (OB100) – not with the PLC-SPL.

10.3.2 Starting the NCK-SPL and PLC-SPL

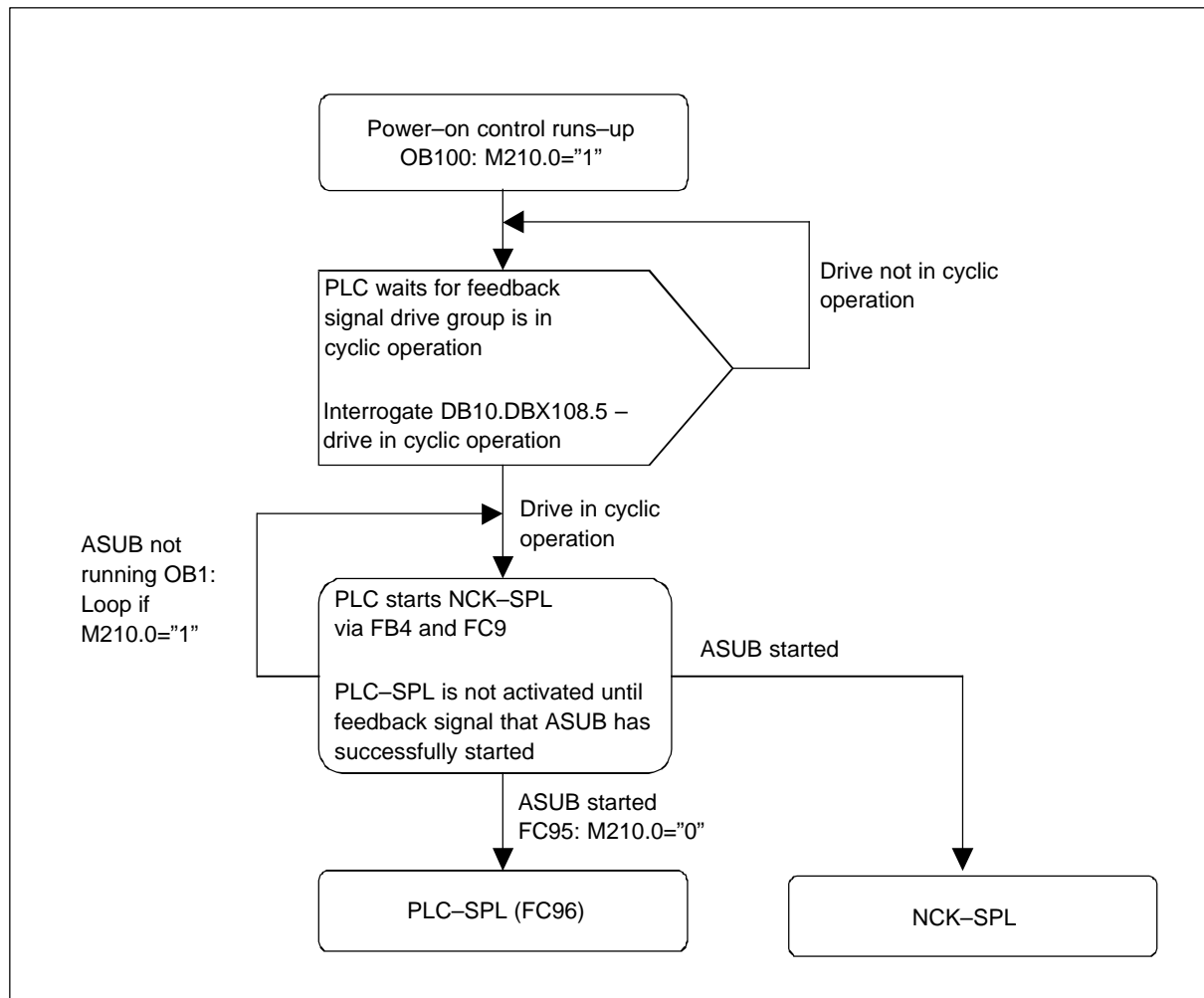

Fig. 10-4 Flowchart

Description

In order to ensure that the crosswise data comparison function does not respond, the NCK-SPL and the PLC-SPL must be started at almost the same time. The PLC program is exclusively responsible in activating the individual SPL programs. The following program excerpt shows how the PLC-SPL and the NCK-SPL can be started almost simultaneously.

An overview of the PLC program structure used is given in the Appendix (Chapter 10.3.12).

Note

From software release 6.4.15 onwards, the NCK-SPL can also be started using the PROG_EVENT mechanism (refer to Chapter 5.10.2)

Program**OB1 program excerpt:**

```
//
// CALL  "GP_HP"           // Basic program
//
// CALL  FC  95           // "Start NCK-SPL"
// U     M  210.0        // NCK-SPL inactive
// BEB                                // PLC-SPL is started
//                                // if NCK-SPL is started
//
// It is not advisable to run any of the user program blocks until
// the ASUB "SAFE.SPF" has run
// Exception: To check the correct functioning of function block FC
// 19, it might be necessary to run it immediately. In this case,
// critical function keys such as RESET/single block must be de-
// activated until the SPL has started:
//
// Example:
// U     M 210.0          // NCK-SPL inactive
// R     E3.7            // Reset RESET key
// R     E3.5            // Reset single block key
// CALL  FC  50          // User program
// CALL  FC  51          // User program
//
// CALL  FC  96          // PLC-SPL
// CALL  FC  97          // Safety test stop
//
```

Description

The NCK-SPL is started with the programs (PLC basic program) FB4 and FC9. Once it has been successfully started, marker 210.0 is reset in order to enable processing of the PLC blocks FC96 (PLC-SPL) and FC97 (safety test) in OB1.

10.3 Safety Integrated with SPL

FC95 program excerpt:

```

TITLE =
VERSION : 0.1

BEGIN
NETWORK
TITLE =

    U M          210.0;           // ASUB start marker from OB100 drive
    U DB10.DBX   108.5;           // group and terminal block have run-up

    FP M        210.1;           // Start edge marker, PI service
    = M          210.2;           // Start cycle marker, PI service
    //
    U M          210.2;           // Start cycle marker, PI service
    S M          210.3;           // Start PI service
    //
    CALL FB4,DB 121 (// PI service interrupt numbers and priority
    Req := M 210.3,               // Start PI service
    PIService:= P#DB16.DBX18.0 BYTE26, // PI service ASUB
    Unit := 1,
    Addr1 := P#DB120.DBX 34.0 BYTE34, // Program path
    Addr2 := P#DB120.DBX 0.0 BYTE34, // Program name
    WVar1 := W#16#1,              // Interrupt number = 1
    WVar2 := W#16#1,              // Priority = 1
    WVar3 := W#16#0,              // LIFTFAST = 0
    WVar4 := W#16#0,              // BLKSYNC
    Error := DB120.DBX68.0        // Fault/error has occurred
    Done := DB120.DBX68.1,        // Request, error-free
    State := DB120.DBW70);        // Error code
    //
    U DB120.DBX 68.1;             // Request successfully completed
    S M          210.4;           // Start ASUB
    R M          210.3;           // Reset PI service start ASUB
    //
    //
    CALL FC      9 (
    Start := M 210.4,             // Start ASUB
    ChanNo := 1,                  // Channel number 1
    IntNo := 1,                   // Interrupt number = 1
    Activ := DB120.DBX72.0,       // ASUB active
    Done := DB120.DBX72.1,        // Request completed
    Error := DB120.DBX72.3,       // Fault/error has occurred
    StartErr := DB120.DBX72.4,    // Interrupt number missing
    Ref := DB120.DBW74);         // Memory range internal
    //

```

```

U DB120.DBX 72.1;           // Request completed ==> ASUB running
S M          210.7;         //
R M          210.0         // Reset ASUB start marker from OB100
R M          210.4;         // Start ASUB reset
//
END_FUNCTION

```

Description

Interrupt number 1 and priority 1 are assigned to the ASUB using FB4. The variables LIFTFAST (fast retraction from the contour) and BLSYNC (the program block is still being processed and the interrupt routine is only started after this) must be assigned the value 0.

Further, it must be noted that the ASUB (SAFE.SPF in the directory CST.DIR) must be started in channel 1 for the NCK-SPL in order that the SPL completely runs-up.

Once FB4 has been successfully executed, the ASUB is started with function FC9. Here it is important that the FC9 bit "Done" is interrogated in order that the program can continue. This is because the PLC-SPL can only be started once the ASUB start task has been completed.

In addition to the FC9 bit "Done", the interface bit "Channel 1-M02/M17/M30 active - DB21.DBX33.5" is also logically combined in order to flag that the ASUB has been completely executed. It might be possible for a user-written M function to be output at the end of ASUB that can be used instead of M02/M17/M30.

10.3.3 Declaring variables

Description

The individual SPL variables must be declared in the NCK–SPL and the PLC–SPL.

On the PLC side, the I/O input and output bits and the Safety Integrated SGEs and SGAs are transferred to DB18 or supplied from DB18. The PLC–SPL only has to be programmed with the variables of DB18 (exception, test stop and the forced–checking procedure of the inputs and outputs).

To ensure clear configuration and programming, it is necessary to list the variables used and to document their meaning. A suggestion for how to do this is documented below. To achieve clarity and uniform formatting, a separate declaration table is created both for the NCK and for the PLC sides. For diagnostics and support during the commissioning phase, both of these tables should be considered as a single–entity in order to clearly represent cross–references.

The two variable tables include all of the variables that are relevant for programming SPL (PLC and NCK sides)

When programming the PLC–SPL, please note that the "worst–case" response time of the PLC also applies. This means, that under worst case conditions, a time difference of 2 PLC cycle times can expire between the input signal changing and the appropriate change of the associated output signal.

A bitwise (bit–serial) overview of the individual signals of the DB18 is provided in the Appendix (Chapter 10.3.12).

A list of the complete NCK–SPL program and the PLC modules that are required for the PLC–SPL is given in Chapter 10.3.10 or Chapter 10.3.11.

Variable declaration NCK

NCK–I/O	NCK variable	Symbolic	Machine data
E1	\$A_INSE[1]	NOT_HALTE	10390 SAFE_IN_HW_ASSIGN[0] = 01040101
E2	\$A_INSE[2]	TUERZUVER	"
E3	\$A_INSE[3]	–	"
E4	\$A_INSE[4]	NOT_QUIT	"
E5	\$A_INSE[5]	SCHLUESSEL	"
E6	\$A_INSE[6]	–	"
E7	\$A_INSE[7]	KL_AS12_XZ	"
E8	\$A_INSE[8]	KL_AS12_C	"

NCK-I/O	NCK variable	Symbolic	Machine data
E9	\$A_INSE[9]	TESTSTOP1E	10390 SAFE_IN_HW_ASSIGN[1] = 01040102
E10	\$A_INSE[10]	TESTSTOP2E	"
E11	\$A_INSE[11]	TEST_STOPA	"
E12	\$A_INSE[12]	TEST_STOPC	"
E13	\$A_INSE[13]	TEST_STOPD	"
E14–E16	\$A_INSE[14–16]	–	"
A1	\$A_OUTSE[1]	NOT_HALT2K	10392 SAFE_OUT_HW_ASSIGN [0] = 01040201
A2	\$A_OUTSE[2]	–	
A3	\$A_OUTSE[3]	KL_663_XZ	"
A4	\$A_OUTSE[4]	KL_663_C	"
–A8	\$A_OUTSE[5–8]	–	"
–	\$A_INSI[1]	IMP_FREI_XZ	36986 SAFE_PULSE_ENABLE_OUTPUT = 04010101 (X, Z)
–	\$A_INSI[2]	IMP_FREI_C	36986 SAFE_PULSE_ENABLE_OUTPUT = 04010102 (C)
–	\$A_OUTSI [1]	STOP_A_ABWS	36977 SAFE_EXT_STOP_INPUT[0] = 04010101 (C)
–	\$A_OUTSI [2]	STOP_A_ABWA	36977 SAFE_EXT_STOP_INPUT[0] = 04010102 (X, Z)
–	\$A_OUTSI [3]	STOP_C_ABW	36977 SAFE_EXT_STOP_INPUT[1] = 04010103 (X, Z, C)
–	\$A_OUTSI [4]	STOP_D_ABW	36977 SAFE_EXT_STOP_INPUT[2] = 04010104 (X, Z, C)
–	\$A_OUTSI [5]	SBH_ABW	36971 SAFE_SS_DISABLE_INPUT = 04010105 (X, Z, C)
–	\$A_OUTSI [6]	SG_BIT_0	36972 SAFE_VELO_SELECT_INPUT = 04010106 (X, Z, C)
–	\$A_OUTSI [7]	TEST1STOP	36975 SAFE_STOP_REQUEST_INPUT = 04010107 (X, C)
–	\$A_OUTSI [8]	TEST2STOP	36975 SAFE_STOP_REQUEST_INPUT = 04010108 (Z)
–	\$A_OUTSI [9]	STAT_IMP_XZ	36976 SAFE_PULSE_STATUS_INPUT = 04010109 (X, Z)
–	\$A_OUTSI [10]	STAT_IMP_C	36976 SAFE_PULSE_STATUS_INPUT = 0401010A (C)
–	\$A_MARKERSI [1]	MERK1	–
–	\$A_MARKERSI [2]	NOT_HALT	–
–	\$A_MARKERSI [3]	QUIT_REQUEST	–
–	\$A_MARKERSI [4]	QUIT_MARKER	–
–	\$A_MARKERSI [5]	–	–

10.3 Safety Integrated with SPL

NCK-I/O	NCK variable	Symbolic	Machine data
–	\$A_MARKERSI [6]	–	–
–	\$A_MARKERSI [7]	STOP_A_A	–
–	\$A_MARKERSI [8]	STOP_A_S	–
–	\$A_TIMERSI[1]	TIMER1	–
–	\$A_TIMERSI[2]	TIMER2	–
–	\$A_TIMERSI[3]	QUIT_TIMER3	–
–	\$A_DBB[4]	QUIT_PLC	–

\$A_INSE/\$A_OUTSE NCK

The external NCK inputs and outputs are assigned bitwise (byte–serially) to the NCK–SPL in the following machine data.

External NCK inputs

MD 10390 SAFE_IN_HW_ASSIGN[0] : \$A_INSE[1..8]
MD 10390 SAFE_IN_HW_ASSIGN[1] : \$A_INSE[9..16]

External NCK outputs

MD 10392 SAFE_OUT_HW_ASSIGN[0] : \$A_OUTSE[1..8]
MD 10392 SAFE_OUT_HW_ASSIGN[1] : \$A_OUTSE[9..16]

assigned to the NCK–SPL bitwise. For the SPL program they are available in the form of system variables \$A_INSE and \$A_OUTSE.

Configuration example:

The terminal block has the logical drive number 4 (according to the drive configuration), the input module being used is inserted in slot 1 (sub–module 1), the output module in slot 2 (sub–module 2).

The results in the following parameterization for the machine data above:

MD 10390 SAFE_IN_HW_ASSIGN[0]: **01 04 01 01 H** (LOW byte)
MD 10390 SAFE_IN_HW_ASSIGN[1]: **01 04 01 02 H** (HIGH byte)
MD 10392 SAFE_OUT_HW_ASSIGN[0]: **01 04 02 01 H** (LOW byte)
MD 10392 SAFE_OUT_HW_ASSIGN[1]: **01 04 02 02 H** (HIGH byte)

\$A_INSI/\$A_OUTSI NCK

The internal inputs and outputs of the SPL logic are assigned using the following machine data:

Internal SPL inputs

MD36980...MD36990 : SGA → \$A_INSI

The SGAs are output signals of the SI function and can be mapped to the system variables \$A_INSI[n]. These can, in turn, be read in the NCK–SPL and used as inputs for the logic operations.

Internal SPL outputs

MD36970...MD36978 : \$A_OUTSI → SGE

The SGEs are input signals of the SI function and their values are supplied from the system variables \$A_OUTSI[n]. These can be written into the NCK–SPL.

Configuration example: Parameterized machine data as shown in the table

\$A_MARKERSI NCK

In order to save intermediate states in the SPL logic, markers are defined. These markers are available in the NCK in system variables \$A_MARKERSI[n]. There is no connection to the machine data.

Configuration example: Assignment as shown in the table

\$A_TIMERSI

In order to program timers in the SPL logic, timers are available in the NCK in system variables \$A_TIMERSI[n]. There is no connection to the machine data.

Configuration example: Assignment as shown in the table

Symbols used

At the beginning of the NCK–SPL (standard cycle SAFE.SPF), freely–selectable names are assigned to system variables \$A_INSE/\$A_OUTSE and \$A_INSI/\$A_OUTSI using the "DEFINE" instruction. This makes the program easier to read and facilitates making changes to the terminal assignment.

The "DEFINE" statements must be placed at the beginning of the NCK–SPL. In the tabular list, names used in the program example are listed in the column headed "Symbolic".

10.3 Safety Integrated with SPL

NCK-SPL program excerpt

```

/
;
; ---- External interfaces ----
;
DEFINE NOT_HALTE           AS $A_INSE[1]
DEFINE TUERZUVER           AS $A_INSE[2]
DEFINE NOT_QUIT            AS $A_INSE[4]
DEFINE SCHLUESSEL         AS $A_INSE[5]
DEFINE KL_AS12_XZ         AS $A_INSE[7]
DEFINE KL_AS12_C          AS $A_INSE[8]
DEFINE TESTSTOP1E         AS $A_INSE[9]
DEFINE TESTSTOP2E         AS $A_INSE[10]
DEFINE TEST_STOPA         AS $A_INSE[11]
DEFINE TEST_STOPC         AS $A_INSE[12]
DEFINE TEST_STOPD         AS $A_INSE[13]
;
DEFINE NOT_HALT2K         AS $A_OUTSE[1]
DEFINE KL_663_XZ          AS $A_OUTSE[3]
DEFINE KL_663_C           AS $A_OUTSE[4]
;
; ---- Internal interfaces ----
;
DEFINE      IMP_FREI_XZ    AS      $A_INSI[1]
DEFINE      IMP_FREI_C    AS      $A_INSI[2]
;
DEFINE      STOP_A_ABWS   AS      $A_OUTSI[1]
DEFINE      STOP_A_ABWA   AS      $A_OUTSI[2]
DEFINE      STOP_C_ABW    AS      $A_OUTSI[3]
DEFINE      STOP_D_ABW    AS      $A_OUTSI[4]
DEFINE      SBHABW        AS      $A_OUTSI[5]
DEFINE      SG_BIT_O      AS      $A_OUTSI[6]
DEFINE      TEST1STOP     AS      $A_OUTSI[7]
DEFINE      TEST2STOP     AS      $A_OUTSI[8]
DEFINE      STAT_IMP_XZ   AS      $A_OUTSI[9]
DEFINE      STAT_IMP_C    AS      $A_OUTSI[10]
;
; ---- Markers ----
;
DEFINE      MERK1         AS      $A_MAKERSI[1]
DEFINE      NOT_HALT     AS      $A_MAKERSI[2]
DEFINE      QUIT_REQUEST AS      $A_MAKERSI[3]
DEFINE      QUIT_MARKER  AS      $A_MAKERSI[4]
DEFINE      STOP_A_A     AS      $A_MAKERSI[7]
DEFINE      STOP_A_S     AS      $A_MAKERSI[8]
;
;

```



```

; ----- Timers -----
;
DEFINE          TIMER1          AS          $A_TIMERSI [1]
DEFINE          TIMER2          AS          $A_TIMERSI [2]
DEFINE          QUIT_TIMER3     AS          $A_TIMERSI [3]
;
;
; ----- Variable Dual Port RAM PLC <-> NCK -----
;
DEFINE          QUIT_PLC        AS          $A_DBB [4]

```

Variable declaration PLC

PLC I/O	DB18 variable	Symbolic	Absolute	Associated bit in axis DB
E76.0	\$A_INSEP[1]	"SPL".NOT_HALTE	DB18.DBX38.0	–
E76.1	\$A_INSEP[2]	"SPL".TUERZUVER	DB18.DBX38.1	–
–	\$A_INSEP[3]	–	DB18.DBX38.2	–
E76.3	\$A_INSEP[4]	"SPL".NOT_QUIT	DB18.DBX38.3	–
E76.5	\$A_INSEP[5]	"SPL".SCHLUESSEL	DB18.DBX38.4	–
–	\$A_INSEP[6]	–	DB18.DBX38.5	–
–	\$A_INSEP[7]	"SPL".KL_AS12_XZ	DB18.DBX38.6	–
–	\$A_INSEP[8]	"SPL".KL_AS12_C	DB18.DBX38.7	–
–	\$A_INSEP[9]	–	DB18.DBX39.0	–
–	\$A_INSEP[10]	–	DB18.DBX39.1	–
–	\$A_INSEP[11]	–	DB18.DBX39.2	–
–	\$A_INSEP[12]	–	DB18.DBX39.3	–
–	\$A_INSEP[13]	–	DB18.DBX39.4	–
–	\$A_INSEP[14–16]	–	DB18.DBX39.5–7	–
A48.2	\$A_OUTSEP[1]	"SPL". NOT_HALT1K	DB18.DBX46.0	–
–	\$A_OUTSEP[2]	–	DB18.DBX46.1	–
–	\$A_OUTSEP[3]	"SPL". KL_663_XZ	DB18.DBX46.2	–
–	\$A_OUTSEP[4]	"SPL". KL_663_C	DB18.DBX46.3	–
–	\$A_OUTSEP[5–8]	–	DB18.DBX46.4–7	–
–	\$A_INSIP[1]	"SPL".IMP_FREI_XZ	DB18.DBX54.0	–
–	\$A_INSIP[2]	"SPL".IMP_FREI_C	DB18.DBX54.1	–

10.3 Safety Integrated with SPL

PLC I/O	DB18 variable	Symbolic	Absolute	Associated bit in axis DB
–	\$A_OUTSIP[1]	"SPL". STOP_A_ABWS	DB18.DBX38.0	DB33.DBX 32.2
–	\$A_OUTSIP[2]	"SPL". STOP_A_ABWA	DB18.DBX38.1	DB31/32.DBX 32.2
–	\$A_OUTSIP[3]	"SPL". STOP_C_ABW	DB18.DBX38.2	DB31/32/33.DBX 32.3
–	\$A_OUTSIP[4]	"SPL". STOP_D_ABW	DB18.DBX38.3	DB31/32/33.DBX 32.4
–	\$A_OUTSIP[5]	"SPL". SBH_ABW	DB18.DBX38.4	DB31/32/33.DBX 22.1
–	\$A_OUTSIP[6]	"SPL". SG_BIT_0	DB18.DBX38.5	DB31/32/33.DBX 22.3
–	\$A_OUTSIP[7]	–	DB18.DBX38.6	–
–	\$A_OUTSIP[8]	–	DB18.DBX38.7	–
–	\$A_OUTSIP[9]	"SPL". STAT_IMP_XZ	DB18.DBX39.0	–
–	\$A_OUTSIP[10]	"SPL". STAT_IMP_C	DB18.DBX39.1	–
–	\$A_MARKERSIP[1]	–	DB18.DBX70.0	–
–	\$A_MARKERSIP[2]	"SPL".NOT_HALT	DB18.DBX70.1	–
–	\$A_MARKERSIP[3]	–	DB18.DBX70.2	–
–	\$A_MARKERSIP[4]	–	DB18.DBX70.3	–
–	\$A_MARKERSIP[5]	"SPL".QUIT_MARKER	DB18.DBX70.4	–
–	\$A_MARKERSIP[6]	–	DB18.DBX70.5	–
–	\$A_MARKERSIP[7]	"SPL".STOP_A_A	DB18.DBX70.6	–
–	\$A_MARKERSIP[8]	"SPL".STOP_A_S	DB18.DBX70.7	–
PLC I/O	PLC variable	Symbolic	Comment	
	T20	TIMER1	STOP c→ STOP A (axes)	
	T21	TIMER2	STOP c→ STOP A (spindle)	
	T22	T_K_ABFALL	Drop-out time of the contactors K1, K2	
	T23	T_VERZUG_1	EMERGENCY STOP input delay	

PLC I/O	DB18 variable	Symbolic	Absolute	Associated bit in axis DB
	T24	T_VERZUG_	Acknowledgment delay time	
–	T30	Teststop_Zeit1	Monitoring duration 2h 40min	
–	T31	Teststop_Zeit2	Monitoring duration 5h 20min	
–	T32	Teststop_Zeit3	Monitoring duration 8h	

\$A_INSEP/\$A_OUTSEP PLC

On the PLC side, the I/O input and output bits must be assigned in SPL interface DB18.

External PLC inputs

```
DB18.DBX38.0 ... DB18.DBX41.7 :      $A_INSEP[1..32]
DB18.DBX42.0 ... DB18.DBX45.7 :      $A_INSEP[33..64]
```

External PLC outputs

```
DB18.DBX46.0 ...DB18.DBX49.7 :      $A_OUTSEP[1..32]
DB18.DBX50.0 ...DB18.DBX53.7 :      $A_OUTSEP[33..64]
```

They are assigned bitwise (bit–serially) in the user program.

Configuration example: Program excerpt FC96 – assignment as shown in the table

```
//
//          Supplies I/Os ==> SPL_DATA_INSEP
//
//
//      U      E      76.0          // Emergency Stop switch
//      =      "SPL".NOT_HALTE
//
//      U      E      76.1          // Door switch
//      =      "SPL".TUERZUVER
//
//      U      E      76.3          // EMERGENCY STOP acknowledgement
//      =      "SPL".NOT_QUIT
//
//      U      E      76.5          // Key-operated switch (SBH
//                                // de-selection)
//      =      "SPL".SCHLUESSEL
//
//
//          The logic operations are located here (SPL)
//
//          Supply SPL_DATA_OUTSEP ==> I/Os
//
//      U      "SPL".NOT_HALT1K    // EMERGENCY STOP 1K
```

10.3 Safety Integrated with SPL

```

      =      A      48.2           // EMERGENCY STOP contactor K1
//

```

\$A_INSIP/\$A_OUTSIP PLC

The same procedure is applied to the internal SPL inputs or outputs:

Internal SPL inputs

```

DB18.DBX54.0 ... DB18.DBX57.7 :      $A_INSIP[1..32]
DB18.DBX58.0 ... DB18.DBX61.7 :      $A_INSIP[33..64]

```

The SGAs are output signals of the SI function and can be mapped to the DB18 variables \$A_INSIP[n]. These can be read into the PLC–SPL and used as inputs for the logic operations.

Internal SPL outputs

```

DB18.DBX62.0 ...DB18.DBX65.7 :      $A_OUTSIP[1..32]
DB18.DBX66.0 ...DB18.DBX69.7 :      $A_OUTSIP[33..64]

```

The SGEs are input signals of the SI function and their values are supplied from the DB18 variables \$A_OUTSIP[n]. These can be written in the PLC–SPL.

Configuration example: Program excerpt FC96 – assignment as shown in the table

```

//                               The logic operations are located here (SPL)
//
//                               Supply SPL_DATA_OUTSIP ==> DB31, DB32, DB33
//
U      "SPL".STOP_A_ABWS      // STOP A for spindle C
=      DB33.DBX 32.2          // Drive interface, drive C
//
U      "SPL".STOP_A_ABWA      // STOP A for axes X, Z
=      DB31.DBX 32.2          // Drive interface, drive X
=      DB32.DBX 32.2          // Drive interface, drive Z
//
// Supply SPL_DATA_OUTSIP ==> DB31, DB32, DB33
//
U      "SPL".STOP_C_ABW       // STOP C for drives X,Z,C
=      DB31.DBX 32.3          // Drive interface, drive X
=      DB32.DBX 32.3          // Drive interface, drive Z
=      DB33.DBX 32.3          // Drive interface, drive C
//
U      "SPL".STOP_D_ABW       // STOP D for drives X,Z,C
=      DB31.DBX 32.4          // Drive interface, drive X
=      DB32.DBX 32.4          // Drive interface, drive Z
=      DB33.DBX 32.4          // Drive interface, drive C

```

```

//
U   "SPL".SBHABW           // SBH de-selection
=   DB31.DBX 22.1         // SBH de-selection, axis X
=   DB32.DBX 22.1         // SBH de-selection, axis X
=   DB33.DBX 22.1         // SBH de-selection, spindle C
//
U   "SPL".SG_BIT_0        // SG bit 0 selection
=   DB31.DBX 22.3         // SG bit 0 axis X
=   DB32.DBX 22.3         // SG bit 0 axis Z
=   DB33.DBX 22.3         // SG bit 0 spindle C

```

This means that the output signals of the SPL are transferred to the axis interface (and therefore influence the outputs). Just like the system used in the NCK (one \$A_OUTSI can be assigned to more than one SGE), one DB18 variable \$A_OUTSIP can be assigned to more than one drive to equally supply SI functions in several axes.

\$A_MARKERSIP PLC

In order to save intermediate states in the SPL logic, markers are defined. These markers must be supplied on the DB18 in accordance with their use in the NCK–SPL.

SPL markers

```

DB18.DBX70.0 ...DB18.DBX73.7 :   $A_MARKERSIP[1..32]
DB18.DBX74.0 ...DB18.DBX77.7 :   $A_MARKERSIP[33..64]

```

Configuration example: Assignment as shown in the table

TIMER PLC

The individual timers can be freely selected in the PLC – there are no associated DB18 signals in the NCK system variables \$A_TIMERSI[n].

Note

The individual timers (NCK: \$A_TIMERSI; PLC: freely selectable) are not listed here (refer to Chapter 10.3.10) because they are not included in the crosswise data and result comparison.

10.3 Safety Integrated with SPL

Symbols used

For the PLC–SPL, the name "SPL" or also a variable type (UDT18) can be assigned to DB18 in the symbol table. A typical module for the UTD18, that defines the DB18 signals bit–serially can be obtained on request from the Hotline (refer to Chapter A.1). The symbolic variable names can then be adapted in this UDT18 and can be adapted to match the user program.

Excerpt from the symbol editor

PLC symbol table			
Symbol	Address	Data type	Comment
SPL	DB18	UDT18	Interface SPL data–area

10.3.4 Connecting–up the drives

Description

1st alternative

On the NCK side, terminals 663 and AS1/AS2 are supplied via inputs and outputs that are allocated to the SPL using machine data (MD10390 /MD10392). These inputs and outputs are monitored by the crosswise data comparison. To avoid undesirable crosswise data comparison errors, the behavior of the NCK must be emulated at the DB18 on the PLC side.

Power can be supplied to terminal AS1 either from terminal 9 or an external +24 V power supply, depending on the cabinet configuration.

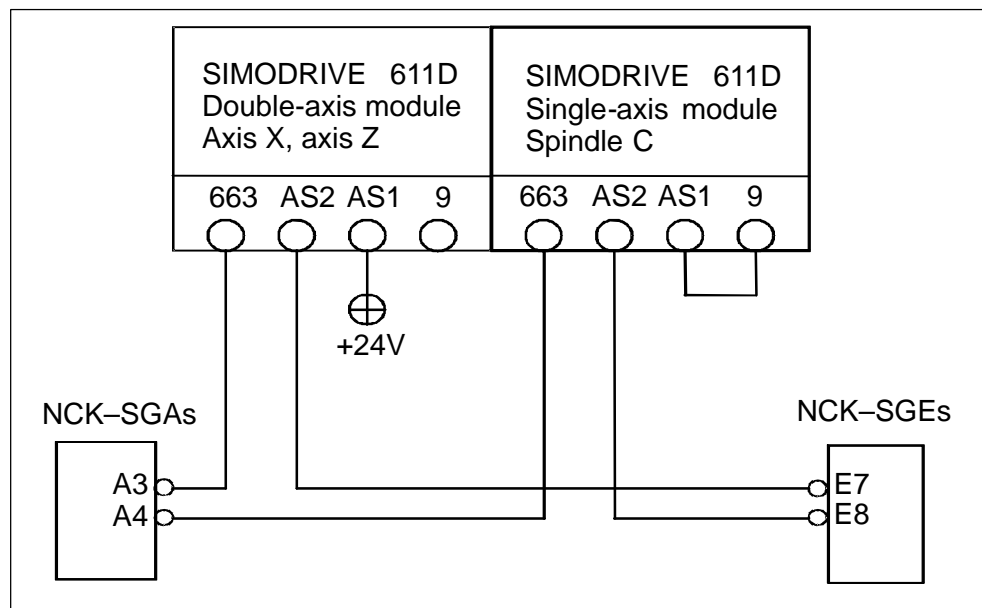

Fig. 10-5 Circuit diagram of the drives

Description

The NCK-SPL contains a copy function from the safe output signal pulse enable (SGA → INSI) to an output (OUTSE → terminal 663) and from an input (terminal AS1/AS2 → INSE) to the safe input signal (OUTSI → SGE) "pulses safely cancelled". INSI/OUTSI system variables are assigned to the SGE/SGA using axis-specific machine data and are listed in Chapter 10.3.3 "Variable declaration".

Program

NCK-SPL program excerpt:

```

;
; -----
; ----- Supply, terminals AS1/AS2 and 663 -----
; -----
;
;
N420 IDS=58 DO STAT_IMP_XZ = KL_AS12_XZ   STAT_IMP_C = KL_AS12_C
N430 IDS=60 DO KL_663_XZ = IMP_FREI_XZ   KL_663_C = IMP_FREI_C
;

```

10.3 Safety Integrated with SPL

Description

The PLC–SPL cannot directly interrogate the status of terminals AS1/AS2 and terminal 663. However, it can interrogate the bit "pulses safely cancelled" at the axis-specific drive interface. The signal status of the system variables used in the NCK–SPL can be emulated using this signal (or group signal for dual-axis modules).

This emulation must be separately programmed for each drive.

Program**FC96 program excerpt:**

```
//
//          Supply DB18 (terminals AS1/AS2 and 663)
//
Simulation of the NCK input (INSE variable)
  U   DB31.DBX 108.2      // Pulses cancelled, axis X
  U   DB32.DBX 108.2      // Pulses cancelled, axis Z
  =   "SPL".KL_AS12_XZ    // Terminal AS1/AS2

  U   DB33.DBX 108.2      // Pulses cancelled, axis C
  =   "SPL".KL_AS12_C     // Terminal AS1/AS2
//
// Assignment INSE (AS1/AS2)  -> OUTSI (SGE: Pulses cancelled)
// Assignment                  -> INSI (SGA: Pulses enabled)
// Assignment INSI (SGA pulses enabled) -> OUTSE (terminal 663)
  U   "SPL".KL_AS12_XZ    // Terminal AS1/AS2
  =   "SPL".STAT_IMP_XZ   // Status, pulses cancelled
  NOT
  =   "SPL".KL_663_XZ     // Terminal 663
  =   "SPL".IMP_FREI_XZ   // Pulse enable X,Z
//
  U   "SPL".KL_AS12_C     // Terminal AS1/AS2
  =   "SPL".STAT_IMP_C    // Status, pulses cancelled
  NOT
  =   "SPL".KL_663_C      // Terminal 663
  =   "SPL".IMP_FREI_C    // Pulse enable C
//
```

Description**2nd alternative**

If separate input and output bytes are provided at the NCK I/Os to supply terminals 663 and AS1/AS2 when engineering the electrical cabinet, then the programming shown above does not apply.

Example:

The two terminals 663 of the drive modules are connected to the second output byte of the DMP output module. This byte is not assigned to the NCK–SPL via machine data:

MD: 10392 SAFE_OUT_HW_ASSIGN[0] = 01040201 H

MD: 10392 SAFE_OUT_HW_ASSIGN[1] = 0 H

The pulse enable by Safety Integrated is directly parameterized using the axis-specific safety machine data at the two outputs 9 and 10:
(mixed operation of safety level 1 and safety level 2 (SPL logic)).

Mixed mode NCK I/Os

When considering the mixed mode for NCK I/Os used in conjunction with Safety Integrated, two cases must be taken into account.

Case 1: Mixed mode, standard I/Os and SI I/Os

Generally, multiple assignments may be made for NCK inputs, i.e. the input can be used both as a standard input with an assignment to \$A_IN[n] (assignment in machine data MD 10366), as an input for Safety Integrated level I (axial assignment in the machine data MD 36970 ... 36978) as well as the input for Safety Integrated stage II (assignment in machine data MD 10390).

However, a multiple assignment only makes sense in exceptional cases. There is no restriction when assigning hardware to the NCK inputs.

The situation is different for the NCK output devices:

If an NCK output of a sub-module (output word) is assigned to the Safety Integrated function (Level I : MD 36980 to MD 36990 or Level II : MD 10392), then the outputs of this sub-module can no longer be used as standard output (MD 10368). This means that only wordwise (word-serial) mixed mode (per sub-module) is possible between the standard output devices and SI output devices.

Case 2: Mixed mode, SI I/Os (without SPL) and SI I/Os (with SPL)

As described above, NCK inputs can be assigned a multiple number of times, i.e. the input or its image can be used both for an assignment in the axial machine data (MD 36970 ... MD 36978) as well as also SPL I/O (MD 10390).

For the NCK outputs, bitwise (byte-serial) mixed operation is possible. This means that if a byte of the sub-module is defined as SPL output (MD 10392), then the output signals on the second sub-module can be used for an assignment in the axial machine data (MD 36980 ... MD 36990). This is particularly recommended in conjunction with the signal "pulses enabled" (MD 36986) so that for this signal it is not necessary to make an entry for the logic.

10.3.5 Emergency Stop

Description

A contactless Emergency Stop function is implemented with the SPL with the same level of safety as for an Emergency Stop function implemented using contacts (discussed in the Foreword to DIN EN 60204–1). Terminal 48 then no longer has to be connected.

Terminals 64 and 63 are permanently connected to 24 V (terminal 9). Terminal 48 must be isolated from the 24 V supply using a leading contact of the main switch.

The line contactor can be switched (if required) in the SPL after the drive pulses have been cancelled. Two channels do not have to be used (e.g. only by the PLC).

Circuit diagram

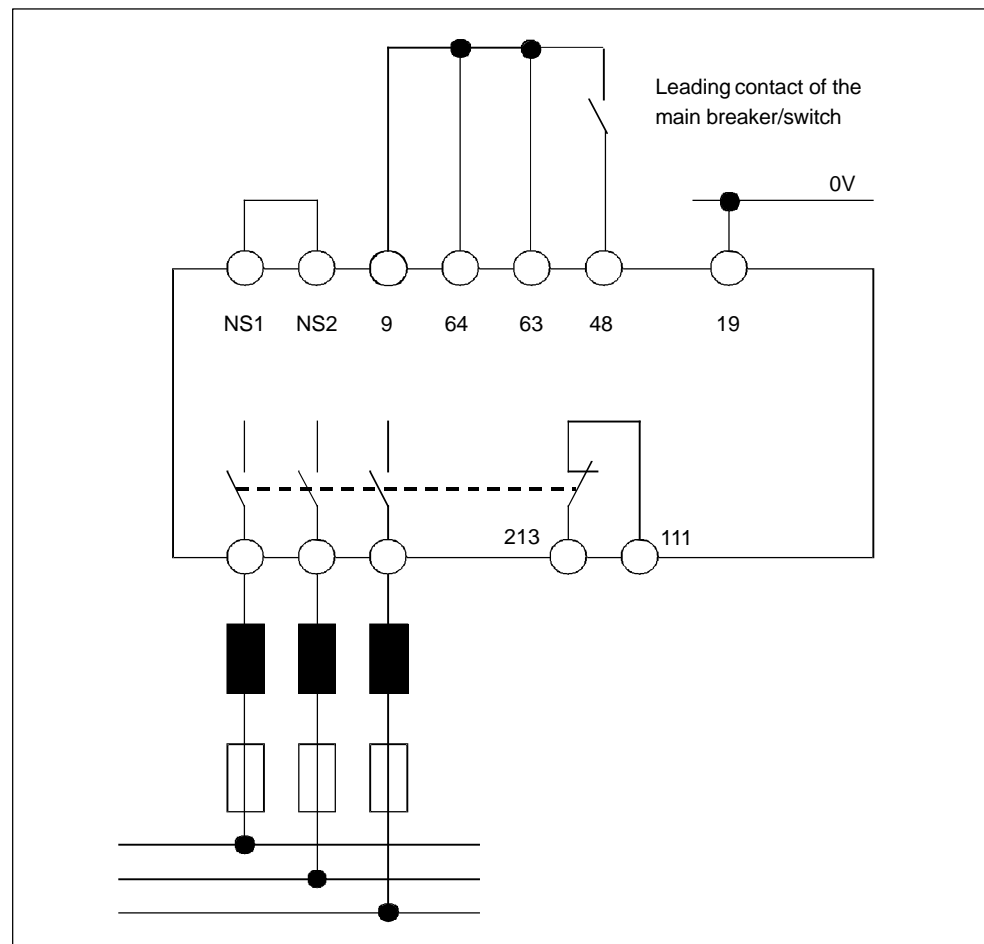

Fig. 10-6 I/R module

Description

The two contacts of the Emergency Stop button are supplied with 24 V (three-terminal concept) via the PLC output. This PLC output is used for the forced checking procedure of the inputs and outputs (refer to Chapter 7.3.6 "Test stop"). The individual circuits of the Emergency Stop button are separately connected to the PLC and NCK inputs.

Circuit diagram

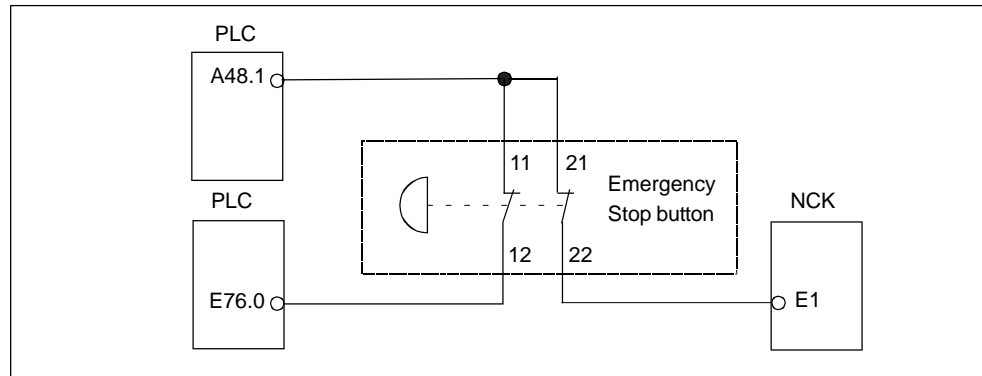

Fig. 10-7 Emergency Stop button

Description

The power to the external actuators is disconnected in the cabinet using two contactors that are controlled redundantly by the PLC and NC. The power contacts are connected in series and therefore disconnect the power through two channels when an Emergency Stop is initiated.

One signaling contact of each of the two contactors is connected in series to the input of the PLC. This PLC input is also used for the forced checking procedure of the inputs and outputs (refer to Chapter 10.3.6).

Circuit diagram

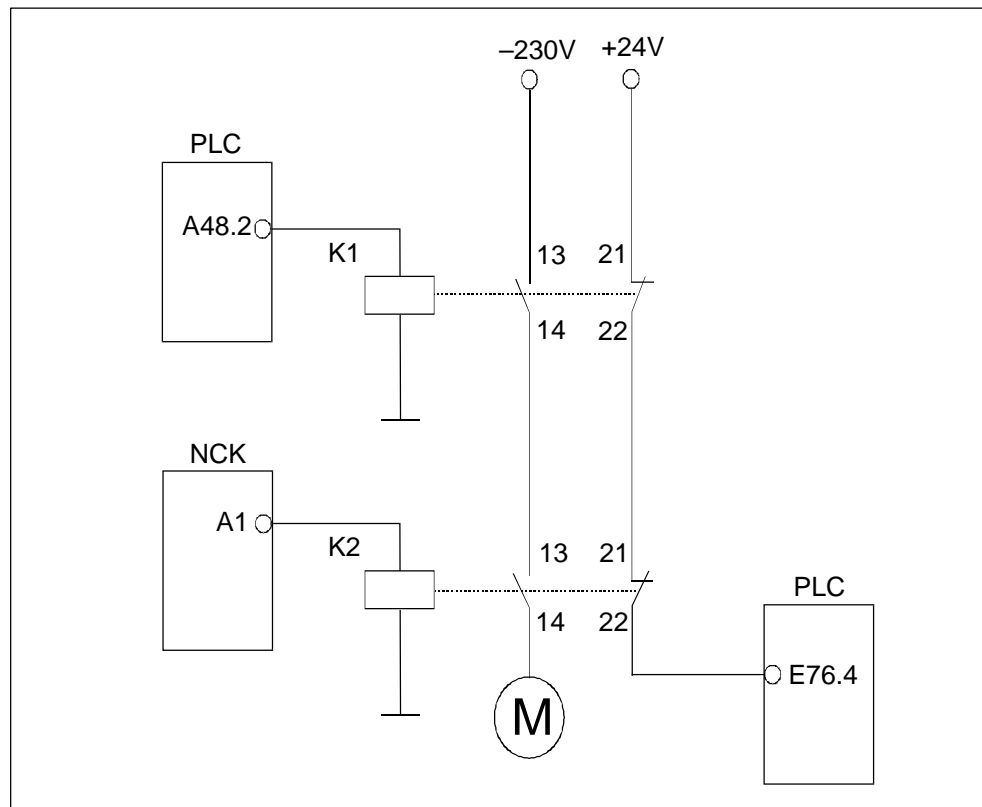

Fig. 10-8 Circuit diagram

Description

An Emergency Stop is acknowledged through two channels using an acknowledge button. This is connected to the +24 V power supply. The safety guidelines published by the German Institute for Occupational Safety state that this switch must be configured using two channels.

If additional feedback signals (e.g. AS1/AS2) have to be incorporated in the acknowledge function, then these contacts should be included in the 24 V power supply of the two-channel acknowledge button.

Circuit diagram

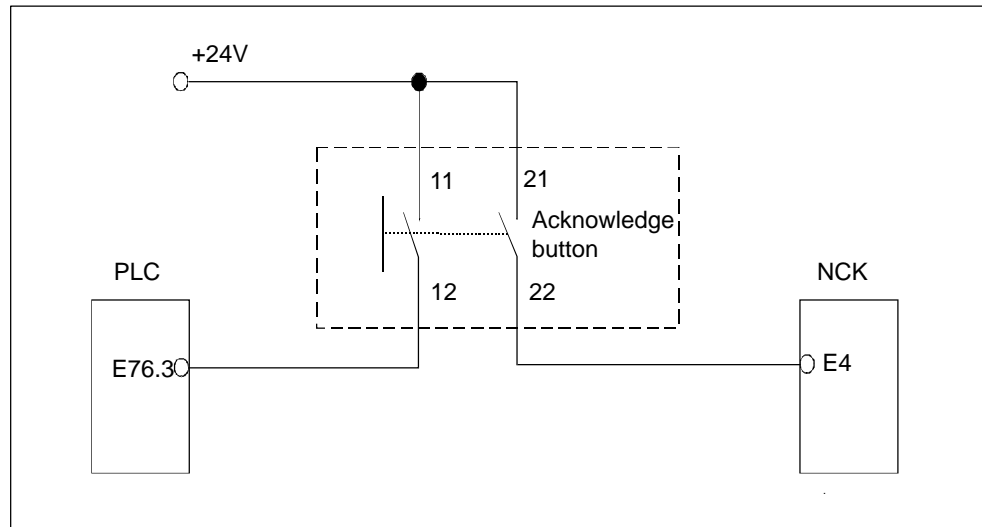

Fig. 10-9 Emergency Stop acknowledge

Description

The "AND" and "OR" blocks shown in the function diagram form a latching element, which is initialized by the acknowledge button (NOT_QUIT/"SPL".NOT_QUIT) when the Emergency Stop button (NOT_AUSE/"SPL".NOT_AUSE) is not actuated and which sets the internal Emergency Stop signal (NOT_AUS/"SPL".NOT_AUS = "1") to "1".

When the Emergency Stop button is pressed (NOT_AUSE/"SPL".NOT_AUSE = "0") this initiates the contactless Emergency Stop (NOT_AUS/"SPL".NOT_AUS = "0"). The "AND" function ensures that acknowledgment is not possible when an Emergency Stop is present.

The contactless Emergency Stop brakes all drives with STOP C ($n_{set} = 0$; STOP_C_ABW/"SPL". STOP_C_ABW = "0") and cancels the pulses for the axes after 1 second (STOP_A_A/"SPL". STOP_A_A = "0") and for the spindles after 5 seconds (STOP_A_S/"SPL". STOP_A_S = "0"). These times must be carefully adapted for each of the machine drives.

If the machine configuration does not allow any of the drives to be braked with STOP C (e.g. a grinding wheel), it is possible to make a distinction between the different types of drive and to brake the drives in question with STOP D (brake along a path) or STOP A (pulse cancellation).

However, a STOP C is the fastest braking method (analog terminal 64 – I/R module). A hazard analysis must be conducted to determine whether any other STOP function is permissible.

The Emergency Stop contactors K1 and K2 (NOT_AUS2K/"SPL". NOT_AUS1K) are switched with the internal Emergency Stop signal (NOT_AUS/"SPL".NOT_AUS = "1").

10.3 Safety Integrated with SPL

Function diagram

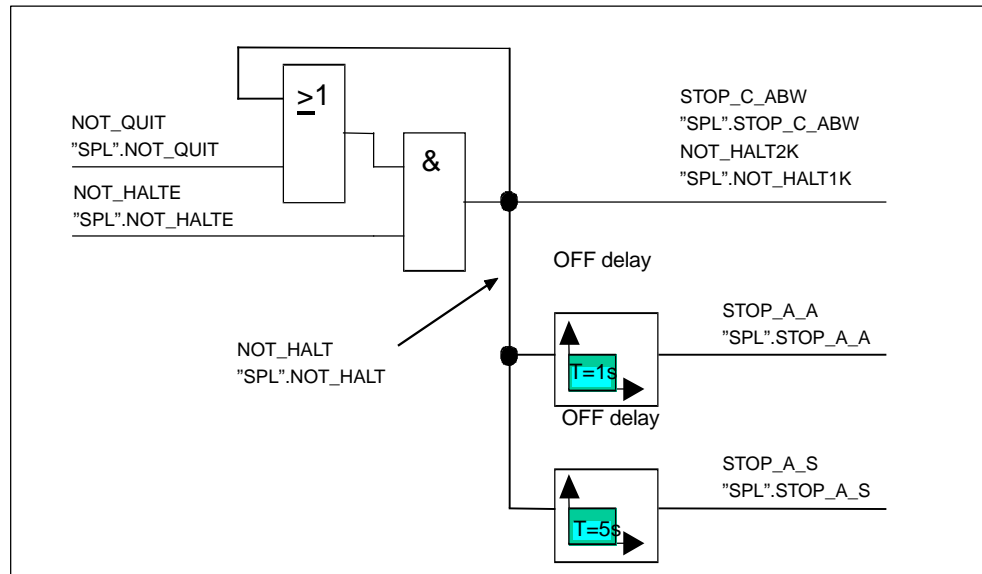

Fig. 10-10 Emergency Stop logic

Program

NCK SPL program excerpt:

```

; N100 IDS=08 EVERY QUIT_PLC == 1 DO QUIT_REQUEST = 1
N101 IDS=09 EVERY QUIT_PLC == 0 DO QUIT_REQUEST = 0
N102 IDS=10 DO QUIT_MARKER = 0
N103 IDS=11 EVERY NOT_HALTE == 0 DO QUIT_TIMER = 0
N104 IDS=12 EVERY NOT_HALTE == 1 DO QUIT_TIMER = -1
N105 IDS=13 EVERY QUIT_REQUEST == 1 DO QUIT_MARKER =
(QUIT_TIMER<0.4)
; -----
N110 IDS=14 DO NOT_HALT = NOT_HALTE AND (NOT_HALT OR NOT_QUIT OR
QUIT_MARKER)
;
N120 IDS=15 EVERY NOT_HALT == 0 DO TIMER1 = 0
N130 IDS=16 EVERY NOT_HALT == 1 DO STOP_A_A = 1 TIMER1=-1
N140 IDS=17 EVERY (TIMER1 > 1.0) AND NOT NOT_HALT DO TIMER1 = -1
STOP_A_A = 0
;
N150 IDS=18 EVERY NOT_HALT == 0 DO TIMER2 = 0
N160 IDS=20 EVERY NOT_HALT == 1 DO STOP_A_S = 1 TIMER2=-1
N170 IDS=22 EVERY (TIMER2 > 5.0) AND NOT NOT_HALT DO TIMER2 = -1
STOP_A_S = 0
;

```

```

N180 IDS=24 DO STOP_A_ABWA = STOP_A_A AND NOT TEST_STOPA
;
N200 IDS=28 DO STOP_A_ABWS = STOP_A_S AND NOT TEST_STOPA
;
N210 IDS=30 DO STOP_C_ABW = NOT_HALT AND NOT TEST_STOPC
;
N220 IDS=32 DO STOP_D_ABW = NOT TEST_STOPD
;
N230 IDS=34 DO NOT_HALT2K = NOT_HALT
;

```

Lines N100–N105 are described in more detail in Chapter 7.3.6 "Test stop". The programming of the function diagram starts in line N110 – where the acknowledgment button and the Emergency Stop button are logically combined. They form the internal "EMERGENCY_STOP" ["NOT_HALT"] signal.

STOP C is selected with "EMERGENCY_STOP=0" ["NOT_HALT=0"] (N210) and the timers for the axes (N120–N140) and the spindles (N150–N170) are started. When each of the timers has elapsed, STOP A is triggered for the axes (N180) and the spindle (N200). STOP D is not used on the NC side but is incorporated in the test stop (refer to Chapter 10.3.6 "Test stop").

The power contactor K2 for the NC side is controlled using instruction line N230.

Program

FC96 program excerpt:

```

//
// ----- Emergency Stop -----
U   "SPL".NOT_HALTE      // Emergency Stop button INSE 1
U(
O   "SPL".NOT_HALT      // Emergency Stop signal internal
O   "SPL".NOT_QUIT      // Acknowledge: Button
O   "SPL".QUIT_MARKER   // Acknowledge FC 97
)
=   "SPL".NOT_HALT      // Emergency Stop signal internal
//
U   "SPL".NOT_HALT      // After pressing Emergency Stop
L   S5T#1S              // Load for 1 second
SA  T    20             // After pressing
U   T    20             // the Emergency Stop
=   "SPL".STOP_A_A     // STOP A: Axes X, Z
//
U   "SPL".NOT_HALT      // After pressing Emergency Stop
L   S5T#5S              // Load for 5 seconds
SA  T    21             // After pressing

```

10.3 Safety Integrated with SPL

```

U    T    21           // the Emergency Stop
=    "SPL".STOP_A_S   // STOP A: Spindle C
//
U    "SPL".STOP_A_A   // STOP A: Axes X, Z
UN   M    216.3       // Test external STOP A (FC 97)
=    "SPL".STOP_A_ABWA // De-select STOP A (X/Z)
//
U    "SPL".STOP_A_S   // STOP A: Spindle C
UN   M    216.3       // Test external STOP A (FC 97)
=    "SPL".STOP_A_ABWS // De-select STOP A (C)
//
U    "SPL".NOT_HALT   // Emergency Stop signal internal
UN   M    216.2       // Test: external STOP C (FC 97)
=    "SPL".STOP_C_ABW // De-select STOP C (X,Z,C)
//
UN   M    216.1       // Test: External STOP D (FC97)
UN   M    218.7       // STOP D dynamized (FC 97)
=    "SPL".STOP_D_ABW // De-select STOP D (X,Z,C)
//
U    "SPL".NOT_HALT   // Emergency Stop pressed
=    "SPL".NOT_HALT1K // EMERGENCY STOP contactor K1
//

```

Description

The structure of the PLC program is identical to that of the NCK–SPL. The additional acknowledgment of the Emergency Stop ("SPL". QUIT_MARKER/DB18.DBX70.4) and the individual tests of the stop functions are described in detail in Chapter 10.3.6.

On the PLC side the power contactor K1 is controlled using the last two instruction lines.

10.3.6 Test stop**Description**

The test stop is conducted at a suitable time (e.g. after eight hours have elapsed and the protective door has been opened). In order to perform various tests on the NC side, signals must be transferred from the PLC to the NCK.

In this example, this is implemented by connecting the PLC outputs to the NCK inputs.

Circuit diagram

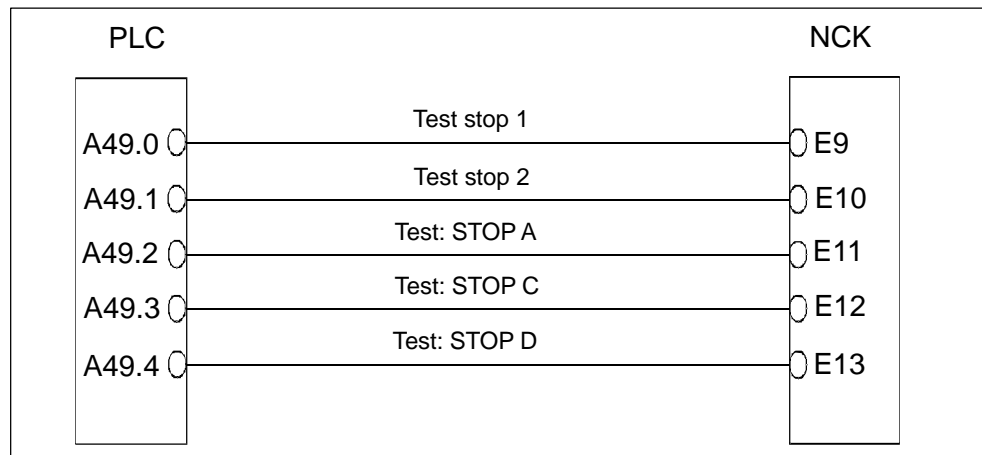

Fig. 10-11 SGE wiring to select a test stop

There are two methods of replacing this wiring by internal data transfer between the PLC and NCK. These two methods are described below.

Supplying SGE to select a test stop (NCK) without wiring

Version 1: Data transfer via the FC 21

An example of how FC21 is used is provided in the FC97 for an automatic Emergency Stop acknowledgment after test stop phase III. The FC 21 is used to transfer a byte (the smallest transferable data structure for the FC 21) from the PLC to the NCK via the dual-port RAM (DPR).

An equivalent method to this is to define for each test stop step (test stop 1, test stop 2, test STOP A, test STOP C, test STOP D) a byte value that corresponds to the particular step.

Example:

Excerpt from an SPL program that shows this principle (this is not part of the actual configuration example).

;DEFINITIONS (relevant sections only)

```

;
; ---- Internal interfaces: OUTSI -> SI-SGE;
;
N6500 DEFINE TESTSTOP_1      AS $A_OUTSI[9]    ; refer to MD 36975
N6500 DEFINE TESTSTOP_1      AS $A_OUTSI[10]   ; refer to MD 36975
;
; ---- Internal interfaces: Markers
;
N8700 DEFINE TEST_STOPA      AS $A_MARKERSI[11]
N8700 DEFINE TEST_STOPA      AS $A_MARKERSI[12]
N8900 DEFINE TEST_STOPD      AS $A_MARKERSI[13]
;

```

10.3 Safety Integrated with SPL

```

; ----- TEST STOP TRIGGER via PLC
;
N9700 DEFINE TESTST_PLC      AS $A_DBB[5]
;
; ----- GENERAL DEFINITIONS
;
N9900  DEFINE BIT_0          AS 1
N10000 DEFINE BIT_1          AS 2
N10100 DEFINE BIT_2          AS 4
N10200 DEFINE BIT_3          AS 8
N10300 DEFINE BIT_4          AS 16
N10400 DEFINE BIT_5          AS 32
N10500 DEFINE BIT_6          AS 64
N10600 DEFINE BIT_7          AS 128

```

PROGRAM EXCERPT (relevant sections only)

```

; Test stop (forced checking procedure/Phase 1/2)

N14000 IDS=41 EVERY TESTST_PLC == BIT_0 DO TESTSTOP_1 = 1
N14100 IDS=42 EVERY TESTST_PLC == BIT_1 DO TESTSTOP_2 = 1

; Test stop (external stops/STOP A/C/D)

N14200 IDS=43 EVERY TESTST_PLC == BIT_2 DO TEST_STOPA = 1
N14300 IDS=44 EVERY TESTST_PLC == BIT_3 DO TEST_STOPC = 1
N14400 IDS=45 EVERY TESTST_PLC == BIT_4 DO TEST_STOPD = 1

```

The markers TEST_STOPA, TEST_STOPC, TEST_STOP_D are also logically combined into the STOP A, STOP C, STOP D de-selection in a similar way to the SPL program of the configuration examples.

The byte in the dual port RAM (\$A_DBB[5] "TESTST_PLC") is assigned the value for the actual test step from the PLC program via the FC 21, i.e. FC 21 transfer is active for the test stops.

Version 2: Data transfer via the simulated NCK-I/Os

It is also possible to replace the wiring using a bitwise (bit-serial) data transfer via the DB 10.

Limitations/secondary conditions

MD 10350 \$MN_FASTIO_DIG_NUM_INPUTS
Number of digital input bytes: 1...5 (standard value 1 – onboard inputs)

MD 10360 \$MN_FASTIO_DIG_NUM_OUTPUTS
Number of digital output bytes: 1...5 (standard value 0)

To use the function for data transfer, MD 10350 and 10360 must be set depending on how many bytes are to be used for data exchange.

If real inputs and outputs are present, they can be used regardless of SI. In this case, MD 10366 \$MN_HW_ASSIGN_DIG_FASTIN and MD 10368 \$MN_HW_ASSIGN_DIG_FASTOUT must be set in accordance with the hardware configuration.

Data exchange can only be used for bytes for which there are no real inputs and outputs.

Data exchange between NCK → PLC

\$A_IN[1..8] → DB10.DBB60
\$A_IN[9..40] → DB10.DBB186..189

\$A_OUT[1..8] → DB10.DBB64
\$A_OUT[9..40] → DB10.DBB190..193

\$A_OUT variables can be written in the NC program
e.g. \$A_OUT[n] = 1

Data exchange between PLC → NC

\$A_IN[1..8] → DB10.DBB1
\$A_IN[9..40] → DB10.DBB123..129

\$A_OUT[1..8] → DB10.DBB6
\$A_OUT[9..40] → DB10.DBB130..141

\$A_IN variables can be read in the NC program

To implement data transfer for the test stop, a bit is allocated to each test stop step. The actual implementation can be seen from the above SPL program excerpt.

10.3 Safety Integrated with SPL

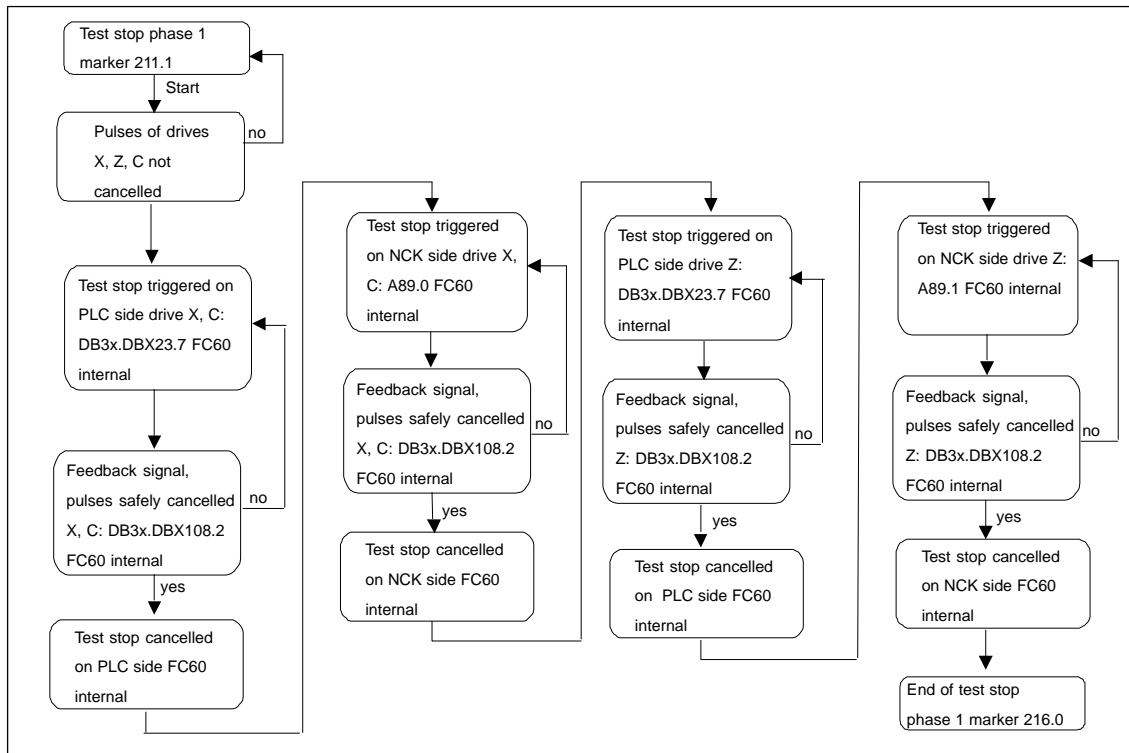

Fig. 10-12 Function diagram

Test stop phase 1

FC97 program excerpt:

```

//
// ----- Forced checking procedure of the pulse cancellation
// -----
UN   M    211.0           // Monitoring time of 8 hours
L    S5T#2H40M          // Load 2 hours and 40 minutes
SE   T    30             // Start timer 30
//
U    T    30             // After 160 minutes
L    S5T#2H40M          // Load 2 hours and 40 minutes
SE   T    31             // Start timer 31
//
U    T    31             // After 160 minutes
L    S5T#2H40M          // Load 2 hours and 40 minutes
SE   T    32             // Start timer 32
//
U    T    32             // After 540 minutes
UN   E    76.1           // Door not closed and interlocked
UN   DB31.DBX108.2      // Pulses not cancelled (X)
UN   DB32.DBX108.2      // Pulses not cancelled (Z)

```

```

UN   DB33.DBX108.2    // Pulses not cancelled (C)
U    DB31.DBX110.5    // Axis X stopped
U    DB32.DBX110.5    // Axis Z stopped
U    DB33.DBX110.5    // Spindle C stopped
S    M    211.1        // Start test phase 1
S    M    211.0        // Reset monitoring time
//
CALL FC 60
start   := M 211.1    // Start test stop 1
reset   := E 3.7      // RESET/MCP
num_axis := 2         // Number of drives
test_axis_1 // Drive number, axis X
:= 1
test_axis_2 // Drive number, spindle C
:= 3

```

Description

After test stop phase 1 has been completed, the external STOPs are tested.

The test sequence is implemented by a simple sequence control in which the external STOPs D, C, A are triggered one after the other in the PLC and then in the same sequence in the NCK. The STOPs are checked by reading back the safe output signals "STOP D, C, A active" into the PLC.

The sequence does not wait for the individual stops to be de-selected before the next stop is tested. This is because the external stop with a higher priority de-activates the external stop with a lower priority!

10.3 Safety Integrated with SPL

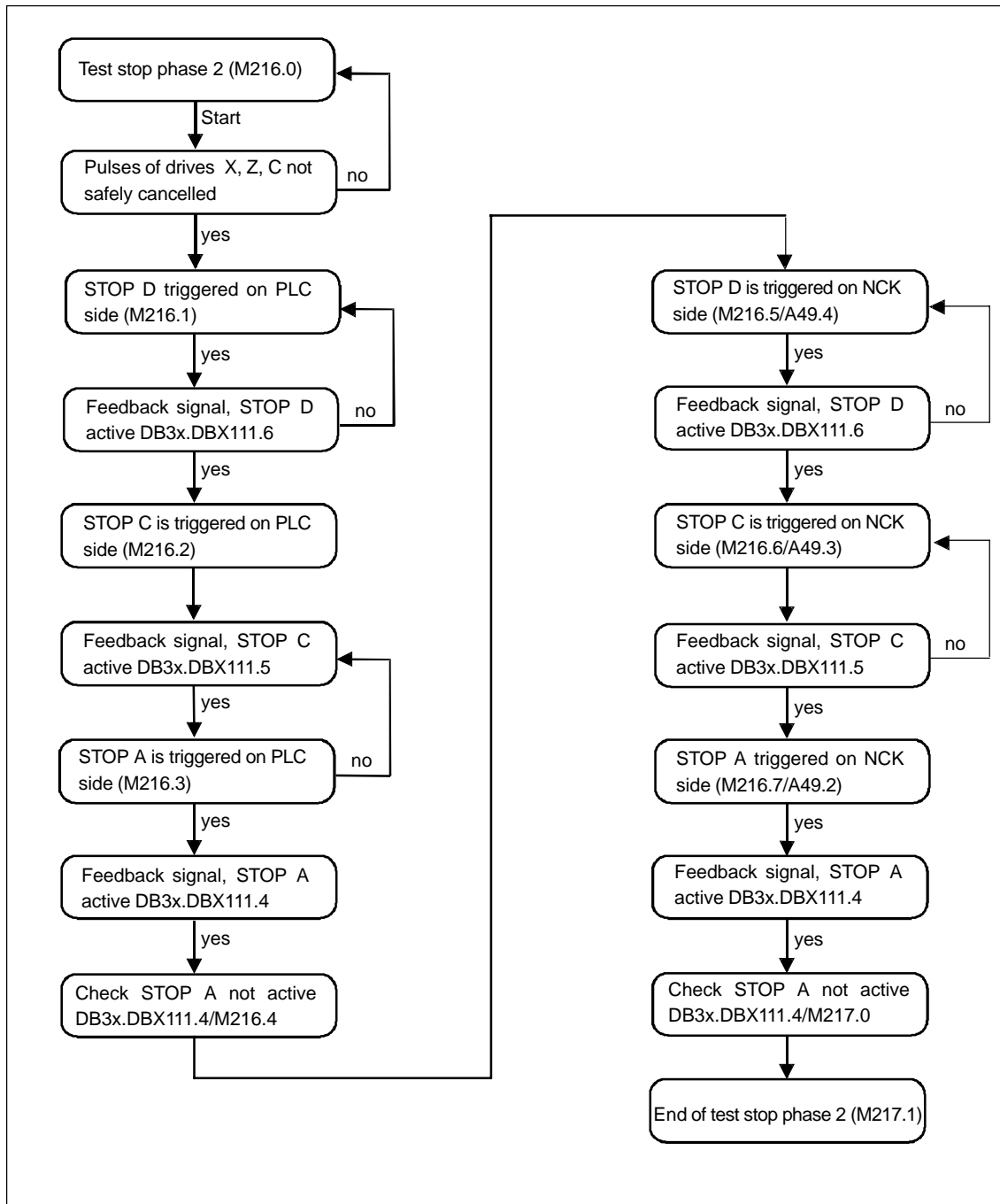

Fig. 10-13 Flowchart

Note

If the sequence control stops at a particular point because a checkback signal has not been received, STOP D is triggered after the crosswise data comparison tolerance time. After the fault has been corrected, the fault can be acknowledged with a reset and the particular test phase completed.

If the Emergency Stop button is actuated during test stop phase 2, the sequence control stops at its current position. As soon as the Emergency Stop is acknowledged, the test phase is completed.

Test stop phase 2**FC97 program excerpt**

```
// Forced checking procedure of the external STOPs A ,C and D
//
U    M    216.0    // Start test stop phase 2
UN   DB31.DBX 108.2 // Axis X, pulses not safely cancelled
UN   DB32.DBX 108.2 // Axis Z, pulses not safely cancelled
UN   DB33.DBX 108.2 // Spindle C, pulses not safely cancelled
S    M    216.1    // Initiate Stop D on PLC side FC96
R    M    216.0    // Reset, start test stop phase 2
//
U    M    216.1    // Check Stop D on the PLC side
U    DB31.DBX 111.6 // STOP D active, axis X
U    DB32.DBX 111.6 // STOP D active, axis Z
U    DB33.DBX 111.6 // STOP D active, spindle C
S    M    216.2    // Initiate Stop C on PLC side FC96
R    M    216.1    // Reset, check Stop D PLC
U    M    216.2    // Check Stop C on the PLC side
U    DB31.DBX 111.5 // STOP C active, axis X
U    DB32.DBX 111.5 // STOP C active, axis Z
U    DB33.DBX 111.5 // STOP C active, spindle C
S    M    216.3    // Initiate Stop A on PLC side FC96
R    M    216.2    // Reset, check Stop C PLC
//
U    M    216.3    // Check Stop A on the PLC side
U    DB31.DBX 111.4 // STOP A/B active, axis X
U    DB32.DBX 111.4 // STOP A/B active, axis Z
U    DB33.DBX 111.4 // STOP A/B active, spindle C
S    M    216.4    // Check: STOP A (PLC) not active
R    M    216.3    // Reset, check Stop A PLC
//
U    M    216.4    // Check: STOP A (PLC) not active
UN   DB31.DBX 111.4 // STOP A/B not active, axis X
```

10.3 Safety Integrated with SPL

```

UN   DB32.DBX 111.4 // STOP A/B not active, axis Z
UN   DB33.DBX 111.4 // STOP A/B not active, spindle C
S    M    216.5     // Initiate Stop D on the NCK side
R    M    216.4     // Reset, check Stop A PLC
//
U    M    216.5     // Initiate Stop D on the NCK side
=    A    49.4     // See circuit diagram and NCK-SPL
//
U    M    216.5     // Check Stop D on the NCK side
U    DB31.DBX 111.6 // STOP D active, axis X
U    DB32.DBX 111.6 // STOP D active, axis Z
U    DB33.DBX 111.6 // STOP D active, spindle C
S    M    216.6     // Initiate Stop C on the NCK side
R    M    216.5     // Reset, check Stop D NCK
//
U    M    216.6     // Initiate Stop C on the NCK side
=    A    49.3     // See circuit diagram and NCK-SPL
//
U    M    216.6     // Check Stop C on the NCK side
U    DB31.DBX 111.5 // STOP C active, axis X
U    DB32.DBX 111.5 // STOP C active, axis Z
U    DB33.DBX 111.5 // STOP C active, spindle C
S    M    216.7     // Initiate Stop A on the NCK side
R    M    216.6     // Reset, check Stop C NCK
//
U    M    216.7;    // Initiate Stop A on the NCK side
=    A    49.2;    // See circuit diagram and NCK-SPL
//
U    M    216.7     // Check Stop A on the NCK side
U    DB31.DBX 111.4 // STOP A/B active, axis X
U    DB32.DBX 111.4 // STOP A/B active, axis Z
U    DB33.DBX 111.4 // STOP A/B active, spindle C
S    M    217.0     // Check: STOP A (NCK) not active
R    M    216.7     // Reset, check Stop A NCK
//
U    M    217.0     // Check: STOP A (NCK) not active
UN   DB31.DBX 111.4 // STOP A/B not active, axis X
UN   DB32.DBX 111.4 // STOP A/B not active, axis Z
UN   DB33.DBX 111.4 // STOP A/B not active, spindle C
S    M    217.1     // Start forced checking procedure at inputs
R    M    217.0     // Reset check: STOP A NCK
//

```

Description

After completion of test stop phase 2, marker 217.1 is set and the forced checking procedure for the inputs is started. The forced checking procedure is performed in the following sequence.

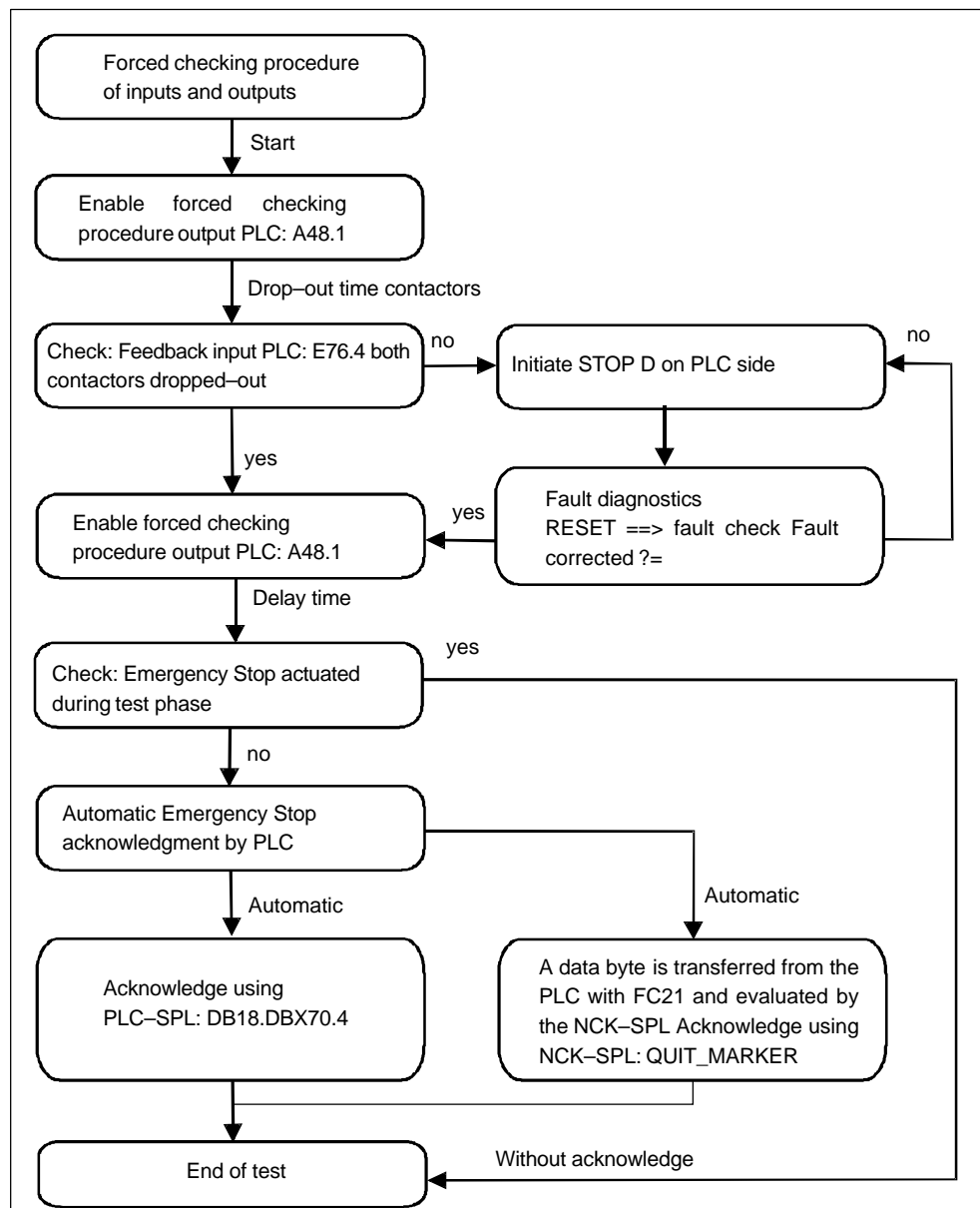

Fig. 10-14 Flowchart

Note

If an Emergency Stop is triggered during the forced checking procedure of the inputs and outputs, the automatic acknowledge is interrupted and the test phase is terminated.

If a fault occurred while checking the feedback input and Emergency Stop is actuated, acknowledge is only possible after the error has been removed (diagnostics) of the feedback input by using the RESET button

10.3 Safety Integrated with SPL

Testing the external inputs and outputs

FC97 program excerpt

```

//
// ----- Forced checking procedure of the inputs/outputs -----
//
U    M    217.1    // Start forced checking proced. for M217.1=1
U    DB18.DBX 70.1 // Emergency Stop not actuated
S    M    218.0    // Check Emergency Stop inputs
R    M    217.1    // Reset: Start forced checking procedure
R    A    48.1    // PLC forced checking procedure output
//
U    M    218.0    // Check Emergency Stop inputs
L    S5T#120MS    // Drop-out time of contactor
SE   T    22      // Set timer 22
//
U    T    22      // After drop-out time of contactor
UN   A    48.1    // PLC forced checking procedure output
UN   E    76.4    // Error, feedback contactor input = 0
S    M    218.7    // Initiate Stop D (refer to FC96)
S    A    48.1    // PLC forced checking procedure output
//
U    T    22      // After drop-out time of contactor
UN   A    48.1    // PLC forced checking procedure output
U    E    76.4    // Good case, feedback contactor input = 1
S    M    218.1    // Start acknowledge
S    A    48.1    // PLC forced checking procedure output
R    M    218.0    // Check Emergency Stop inputs
//
U    T    22      // After drop-out time of contactor
U    E    3.7     // RESET MCP
U    E    76.0    // Emergency Stop (PLC) not actuated
U    E    76.4    // Forced checking procedure input E76.4=1
S    M    218.1    // Start acknowledge
R    M    218.0    // Check Emergency Stop inputs
R    M    218.7    // Withdraw Stop D
//
U    M    218.1    // Start acknowledge
L    S5T#50MS    // Delay time for Emergency Stop inputs
SE   T    23      // Set timer 23
//
U    T    23      // Delay time for Emergency Stop inputs
UN   E    76.0    // Emergency Stop actuated
R    M    218.1    // Reset acknowledge
//
U    T    23      // Delay time for Emergency Stop inputs
U    E    76.0    // Emergency Stop not actuated
U    E    76.4    // Forced checking procedure input E76.4=1

```

```

S    DB18.DBX 70.4 // Acknowledge Emergency Stop PLC
S    M    218.2    // Acknowledge Emergency Stop NCK
R    M    218.1    // Check: Emergency Stop
//
U    DB18.DBX 70.4 // Acknowledge Emergency Stop PLC
L    S5T#200MS    // Delay time: Acknowledge NCK/PLC
SE   T    24      // Set timer 24
//
U    T    24      // Acknowledge Emergency Stop
S    M    218.3    // Withdraw acknowledge NCK
R    M    218.2    // Acknowledge Emergency Stop NCK
//
UN   M    218.2    // Acknowledge Emergency Stop NCK
SPB  QUI1        // Do not acknowledge NCK
//
L    1          // Load 1
T    MB    194   // Transfer marker byte 194
//
QUI1: UN   M 218.3; // Withdraw acknowledge NCK
      SPB  QUI2;   //
//
L    0;        // Load 0
T    MB    194; // Transfer marker byte 194
//
QUI2: NOP    0; //
//
//
CALL FC 21 ( //
      Enable := DB18.DBX70.4,
      Funct  := B#16#4,
      S7Var  := P#M 194.0 BYTE 1,
      IVAR1  := 4,
      IVAR2  := -1,
      Error  := M    218.4,
      ErrCode := MW   188);
//
U    M    218.3; // Withdraw acknowledge NCK
U    DB18.DBX 70.1; // Acknowledge Emergency Stop PLC o.k.
UN   DB18.DBX110.1; // No difference between NCK/PLC
UN   M    218.4; // No error during transfer
R    DB18.DBX 70.4; // Acknowledge Emergency Stop PLC
R    M    218.3; // Reset: Withdraw acknowledge NCK
R    M    211.0; // Start monitoring time of 8 hours

```

Description

After the PLC has started the automatic acknowledgment, the Emergency Stop on the PLC side is acknowledged using the SPL marker "SPL".QUIT_MARKER/DB18.DBX70.4. When acknowledgment is started, an S7 variable (MB194) is

10.3 Safety Integrated with SPL

transferred using FC21 with a value of "1" and is then evaluated by the NCK–SPL in lines N100 to N105.

The PLC (FC 21) can only transfer data to the NC with a minimum length of one byte. This byte can be read into the synchronous actions by system variable \$A_DBB[n]. However, the binary logic operations "AND" and "OR" cannot combine a bit with a byte so that the byte sent (\$A_DBB[4]) must be converted to a bit (\$A_MARKERSI[3]/QUIT_REQUEST) (lines N100/N101).

As a result of lines N102 to N105, automatic acknowledgment is only permitted if the "1" signal level of the NCK Emergency Stop input is not interrupted for longer than 400 ms. In order to check this time, a timer is started (line N103) when the signal level changes from "1" to "0" at the Emergency Stop input. This is checked when automatic acknowledgment is to be made (line N105). An acknowledgment is only issued if the time is < 400 ms. Otherwise an attempt to automatically acknowledge an Emergency Stop is prevented. This additional safeguard is necessary because at this point Emergency Stop is acknowledged by the PLC using a single-channel in both SPL programs.

The acknowledgment request on the NCK side (QUIT_REQUEST/QUIT_MARKER) and the PLC side ("SPL".QUIT_MARKER) are located at different SPL markers MARKERSI[3,4,5] in order to detect the error that each acknowledgment request has the steady-state status "1".

Program

```

DEFINE QUIT_PLC AS $A_DBB[4]
;
; -----
; ----- Emergency Stop -----
; -----
;
N100 IDS=08 EVERY QUIT_PLC == 1 DO QUIT_REQUEST = 1
N101 IDS=09 EVERY QUIT_PLC == 0 DO QUIT_REQUEST = 0
N102 IDS=10 DO QUIT_MARKER = 0
N103 IDS=11 EVERY NOT_HALTE == 0 DO QUIT_TIMER3 = 0
N104 IDS=12 EVERY NOT_HALTE == 1 DO QUIT_TIMER3 = -1
N105 IDS=13 EVERY QUIT_REQUEST == 1 DO QUIT_MARKER =
(QUIT_TIMER3<0.4)
; -----
N110 IDS=14 DO NOT_HALT = NOT_HALTE AND (NOT_HALT OR NOT_QUIT OR
QUIT_MARKER)

```

After 200 ms (T24) has elapsed, acknowledgment is cancelled by transferring the S7 variable with value "0" (MB194). Forced checking procedure of the inputs and outputs is completed as soon as the variables have been sent in FC21.

Note

The time for timer 22 must be matched to the drop-out time of the contactors used. The times for timers 23 and 24 are dependent on the PLC cycle time and have to be appropriately adapted.

10.3.7 Protective door interlocking

Description

In this example, the two-channel door switch feedback signal "Door closed and interlocked" is used and connected to one input of the NCK I/Os and one input of the PLC I/Os. The door switch is monitored through two channels by the crosswise data comparison of the NCK and PLC inputs. The signal is available as INSE[2]/TUERZUVER and INSEP[2]/"SPL".TUERZUVER for programming the NCK-SPL and PLC-SPL.

The door solenoids are enabled by the PLC so that the request to "open door" is made with a single-channel button (e.g. MCP). The signal "door closed" from the door switch is also made available to the PLC to automatically interlock the door switch with the door solenoids when the protective door is closed.

10.3 Safety Integrated with SPL

Circuit diagram

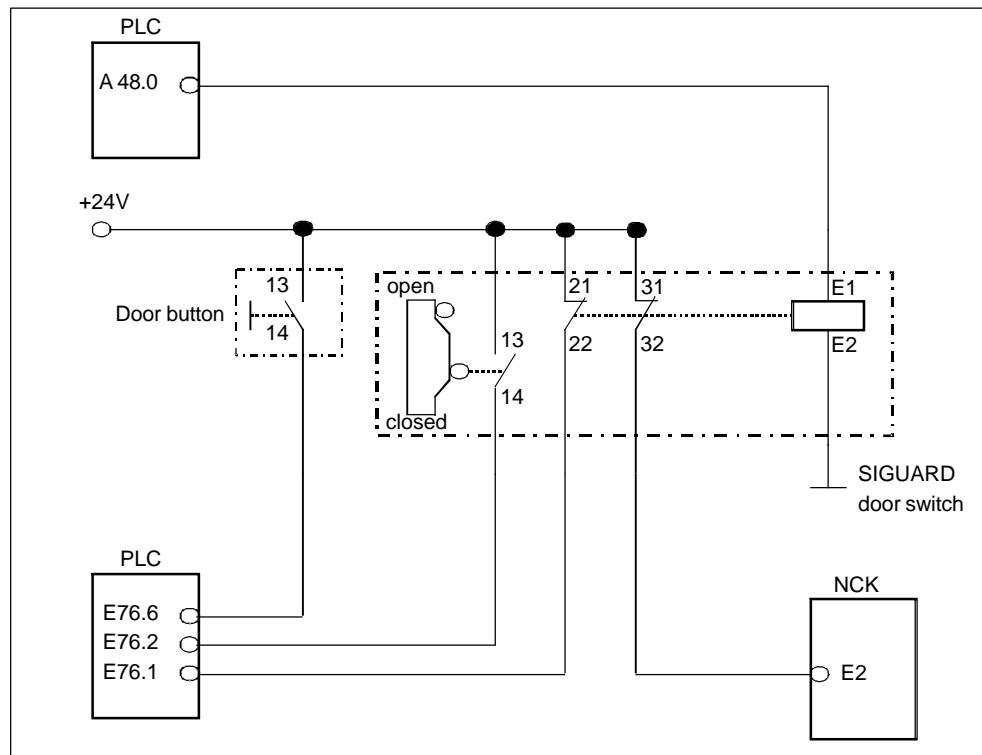

Fig. 10-15 Connecting-up the door switch

Note

If external devices and equipment (hydraulics, cooling water, etc.) are to be powered-down/disconnected when the door is opened, then in this case, the same contactor circuit configuration should be used as for the Emergency Stop (K1/K2). This means that an output must be supplied – in the PLC-SPL ($\$A_OUTSEP[n]$) as well as in the NCK-SPL ($\$A_OUTSE[n]$) – that drops-out when the door opens. The feedback input must be checked every time that the protective door is opened, or even better, it should be integrated into the forced checking procedure of the inputs/outputs (error response STOP D from PLC) – if it cannot be guaranteed that the door will be opened once within eight hours.

10.3.8 De-selecting SBH using the key-operated switch

Circuit diagram

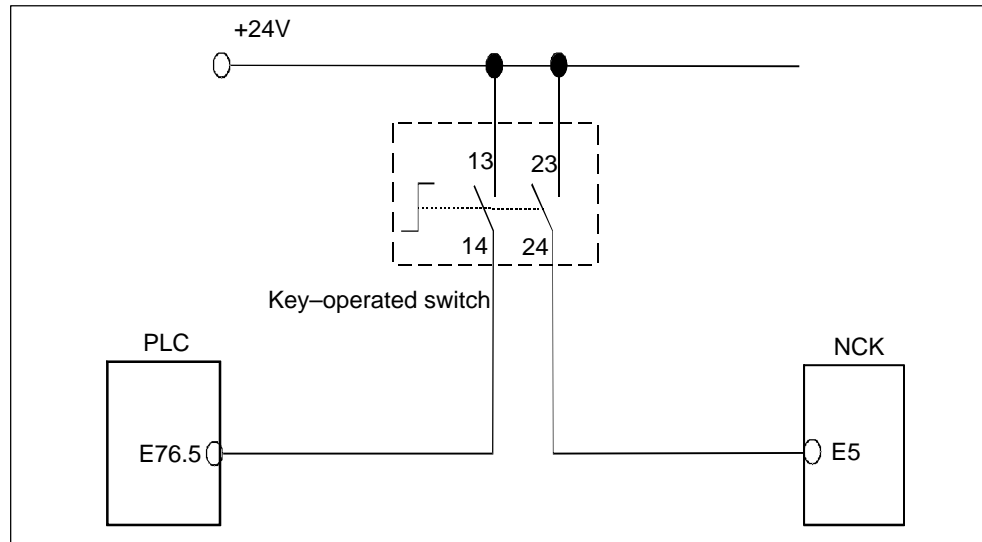

Fig. 10-16 Connecting-up the key-operated switch

Function diagram

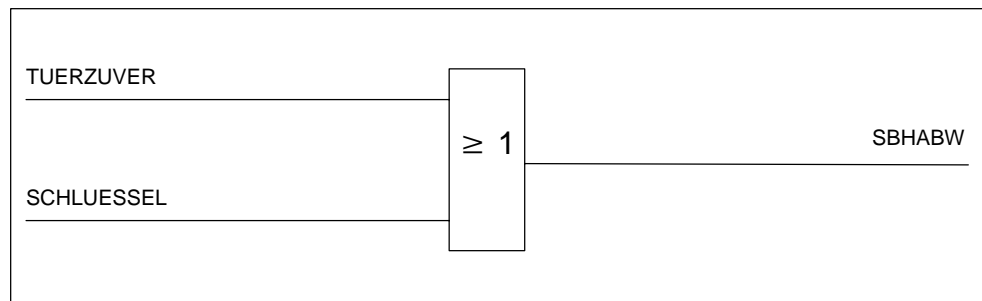

Fig. 10-17 Function diagram, SBH de-selection

10.3 Safety Integrated with SPL

Program**NCK–SPL program excerpt:**

```

;
; -----
; -----SBH DE-SELECTION USING KEY-OPERATED SWITCH -----
; -----
;
;
N380 IDS=50 DO SBHABW = SCHLUESSEL OR TUERZUVER
;

```

Program**FC96 program excerpt:**

```

//
// ----- SBH de-selection using the key-operated switch -----
//
//
U      "SPL".SCHLUESSEL      // Key-operated switch
O      "SPL".TUERZUVER      // Door closed and interlocked
=      "SPL".SBHABW         // SBH de-selection

```

Machine data

The standstill tolerance is saved in the axis-specific machine data and in the drive machine data (FD/MSD).

```
36930 / 1330  SAFE_STANDSTILL_TOL
```

10.3.9 SG changeover**Description**

The SG stage is selected depending on the status of the protective door. When the protective door is opened, SG stage (SG1 = 2 m/min ; SG1 = 50 RPM) is active and when the protective door is closed, SG stage 2 (SG2 = 10 m/min ; SG2 = 2000 RPM) is active. The speed limits are saved in the axis-specific machine data and in the drive machine data (FD/MSD).

Machine data

```
36931/1331  SAFE_VELO_LIMIT[0/1]
```

Function diagram

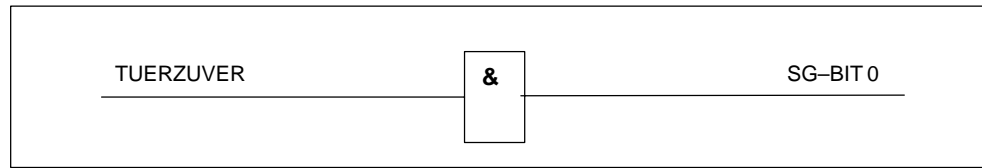

Fig. 10-18 Function diagram, SG selection

Program

NCK-SPL program excerpt

```

;
; -----
; ----- SG selection using the protective door -----
; -----
;
;
;
N390 IDS=52 DO SG_BIT_O = TUERZUVER
;

```

Program

FC96 program excerpt:

```

//
// ----- SG selection using the protective door -----
//
//
U   "SPL".TUERZUVER    // Door closed and interlocked
=   "SPL".SG_BIT_0    // SG bit 0
//

```

10.3 Safety Integrated with SPL

10.3.10 NCK-SPL

```

%_N_SAFE_SPF
;$PATH=/_N_CST_DIR).
; SAFE_CHECKSUM = 000429caH
;
=====

; File:      safe.spf
; Author:
; Creation date:
; -----
; "Drives: one spindle + two feed drives"
; "Contactless Emergency Stop + forced checking procedure"

; "Test stop"
; "SBH/SG selection using the key-operated switch when the protective
; door is open"
; =====
;
; ---- External interfaces ----
;
DEFINE NOT_HALTE      AS $_INSE[1]
DEFINE TUERZUVER      AS $_INSE[2]
DEFINE NOT_QUIT       AS $_INSE[4]
DEFINE SCHLUESSEL     AS $_INSE[5]
DEFINE KL_AS12_XZ     AS $_INSE[7]
DEFINE KL_AS12_C      AS $_INSE[8]
DEFINE TESTSTOP1E     AS $_INSE[9]
DEFINE TESTSTOP2E     AS $_INSE[10]
DEFINE TEST_STOPA     AS $_INSE[11]
DEFINE TEST_STOPC     AS $_INSE[12]
DEFINE TEST_STOPD     AS $_INSE[13]
;
DEFINE NOT_HALT2K     AS $_OUTSE[1]
DEFINE KL_663_XZ     AS $_OUTSE[3]
DEFINE KL_663_C      AS $_OUTSE[4]
;
;
; ---- Internal interfaces ----
DEFINE IMP_FREI_XZ    AS $_INSI[1]
DEFINE IMP_FREI_C     AS $_INSI[2]
;
DEFINE STOP_A_ABWS    AS $_OUTSI[1]
DEFINE STOP_A_ABWA    AS $_OUTSI[2]
DEFINE STOP_C_ABW     AS $_OUTSI[3]
DEFINE STOP_D_ABW     AS $_OUTSI[4]
DEFINE SBHABW AS $_OUTSI[5]
DEFINE SG_BIT_O       AS $_OUTSI[6]
DEFINE TEST1STOP      AS $_OUTSI[7]
DEFINE TEST2STOP      AS $_OUTSI[8]
DEFINE STAT_IMP_XZ    AS $_OUTSI[9]
DEFINE STAT_IMP_C     AS $_OUTSI[10]
;

```

```

;
;
; ---- Markers ----
DEFINE MERK1          AS $A_MARKERSI[1]
DEFINE NOT_HALT       AS $A_MARKERSI[2]
DEFINE QUIT_REQUEST   AS $A_MARKERSI[3]
DEFINE QUIT_MARKER    AS $A_MARKERSI[4]
DEFINE STOP_A_A       AS $A_MARKERSI[7]
DEFINE STOP_A_S       AS $A_MARKERSI[8]
;
;
; ---- Timers ----
DEFINE TIMER1         AS $A_TIMERSI[1]
DEFINE TIMER2         AS $A_TIMERSI[2]
DEFINE QUIT_TIMER3    AS $A_TIMERSI[3]
;
;
; ---- Emergency Stop acknowledgment via PLC ----
DEFINE QUIT_PLC AS $A_DBB[4]
;
;
; -----
N0040 MSG("SPL Start")
; -----
; -----
; ----- Emergency Stop -----
; -----
;
;
N100 IDS=08 EVERY QUIT_PLC == 1 DO QUIT_REQUEST = 1
N101 IDS=09 EVERY QUIT_PLC == 0 DO QUIT_REQUEST = 0
N102 IDS=10 DO QUIT_MARKER = 0
N103 IDS=11 EVERY NOT_HALTE == 0 DO QUIT_TIMER3 = 0
N104 IDS=12 EVERY NOT_HALTE == 1 DO QUIT_TIMER3 = -1
N105 IDS=13 EVERY QUIT_REQUEST == 1 DO QUIT_MARKER = (QUIT_T
MER3<0.4)
; -----
N110 IDS=14 DO NOT_HALT = NOT_HALTE AND (NOT_HALT OR NOT_QUIT OR
QUIT_MARKER)
;
N120 IDS=15 EVERY NOT_HALT == 0 DO TIMER1 = 0
N130 IDS=16 EVERY NOT_HALT == 1 DO STOP_A_A = 1 TIMER1=-1
N140 IDS=17 EVERY (TIMER1 > 1.0) AND NOT NOT_HALT DO TIMER1 = -1
STOP_A_A = 0
;
N150 IDS=18 EVERY NOT_HALT == 0 DO TIMER2 = 0
N160 IDS=20 EVERY NOT_HALT == 1 DO STOP_A_S = 1 TIMER2=-1
N170 IDS=22 EVERY (TIMER2 > 5.0) AND NOT NOT_HALT DO TIMER2 = -1
STOP_A_S = 0
;
N180 IDS=24 DO STOP_A_ABWA = STOP_A_A AND NOT TEST_STOPA
;

```

10.3 Safety Integrated with SPL

```

N200 IDS=28 DO STOP_A_ABWS = STOP_A_S AND NOT TEST_STOPA
;
N210 IDS=30 DO STOP_C_ABW = NOT_HALT AND NOT TEST_STOPC
;
N220 IDS=32 DO STOP_D_ABW = NOT TEST_STOPD
;
N230 IDS=34 DO NOT_HALT2K = NOT_HALT
;
;
; -----
; -----SBH DE-SELECTION USING KEY-OPERATED SWITCH -----
; -----
;
;
N380 IDS=50 DO SBHABW = SCHLUESSEL OR TUERZUVER
;
;
; -----
; ----- SG selection using the protective door -----
; -----
;
;
N390 IDS=52 DO SG_BIT_O = TUERZUVER
;
;
; -----
; ----- TEST STOP -----
; -----
;
;
N400 IDS=54 DO TEST1STOP = TESTSTOP1E
N410 IDS=56 DO TEST2STOP = TESTSTOP2E
;
;
; -----
; ----- Supply, terminals AS1/AS2 and 663 -----
; -----
;
;
N420 IDS=58 DO STAT_IMP_XZ = KL_AS12_XZ STAT_IMP_C = KL_AS12_C
N430 IDS=60 DO KL_663_XZ = IMP_FREI_XZ KL_663_C = IMP_FREI_C
;
; -----
N1040 MSG("SPL active")
; -----
N1070 M17

```

10.3.11 PLC blocks**FUNCTION FC 95 : VOID**

```

        TITLE =
        VERSION : 0.1

        BEGIN
        NETWORK
        TITLE =

        U      M      210.0;           // ASUB start marker from OB100
        U      DB10.DBX 108.5;        // Drive group and terminal block
                                        // run-up

        FP     M      210.1;           // Start edge marker, PI service
        =      M      210.2;           // Start cycle marker, PI service
//
        U      M      210.2;           // Start cycle marker, PI service
        S      M      210.3;           // Start PI service
//
        CALL FB      4 , DB 121        // PI service interrupt no. and
                                        // priority
        Req        := M 210.3,         // Start PI service
        PIService:= P#DB16.DBX 18.0 BYTE 26, // PI service ASUB
        Unit       := 1,               //
        Addr1 := P#DB120.DBX 34.0 BYTE 34, // Program path
        Addr2 := P#DB120.DBX 0.0 BYTE 34, // Program name
        WVar1     := W#16#1,           // Interrupt number = 1
        WVar2     := W#16#1,           // Priority = 1
        WVar3     := W#16#0,           // LIFTFAST = 0
        WVar4     := W#16#0,           // BLKSYNC
        Error     := DB120.DBX 68.0,   // Fault/error has occurred
        Done      := DB120.DBX 68.1,   // Request, error-free
        State     := DB120.DBW 70);    // Error code
//
        U      DB120.DBX 68.1;         // Request successfully completed
        S      M      210.4;           // Start ASUB
        R      M      210.3;           // Reset PI service start ASUB
//
//
        CALL FC 9 (
        Start     := M210.4,           // Start ASUB
        ChanNo    := 1,                // Channel number 1
        IntNo     := 1,                // Interrupt number = 1
        Activ     := DB120.DBX 72.0,   // ASUB active

```

10.3 Safety Integrated with SPL

```

Done      := DB120.DBX 72.1,      // Request completed
Error     := DB120.DBX 72.3,      // Error occurred
StartErr  := DB120.DBX 72.4,      // Interrupt number missing
Ref       := DB120.DBW 74);        // Memory range internal
//
U        DB120.DBX 72.1;           // Request completed ==> ASUB run-
                                   ning
S        M    210.7;               // Reset ASUB start marker from
                                   // OB100
R        M    210.0;               // Start ASUB reset
//
END_FUNCTION

```

FUNCTION FC 96 : VOID

```

TITLE =
VERSION : 0.1

BEGIN
NETWORK
TITLE =supplying I/Os with signals from/to PLC-SPL
// Supply I/Os ==> SPL_DATA_INSEP

//
U        E    76.0;                // Emergency Stop switch
=        "SPL".NOT_HALTE;
//
U        E    76.1;                // Door switch (closed and interlocked)
=        "SPL".TUERZUVER;
//
U        E    76.3;                // Emergency Stop acknowledge
=        "SPL".NOT_QUIT;
//
U        E    76.5;                // Key-operated switch (SBH de-selection)
=        "SPL".SCHLUESSEL;        //
//
NETWORK
TITLE =
//----- Emergency Stop -----
//
U        "SPL".NOT_HALTE          // Emergency Stop button INSE 1
U(      ;                          //
O        "SPL".NOT_HALT;          // Emergency Stop signal internal
O        "SPL".NOT_QUIT;         // Emergency Stop acknowledge
O        "SPL".QUIT_MARKER;      // Emergency Stop acknowledge forced
//
)      ;                          //
=        "SPL".NOT_HALT;          // Emergency Stop signal internal

```

```

//
U   "SPL".NOT_HALT;    // After pressing
L   S5T#1S;           // Load for 1 second
SA  T   20;           // After pressing Emergency Stop
U   T   20;           //
=   "SPL".STOP_A_A;   // Intermediate marker STOP A for
                        // axes X,Z
//
U   "SPL".NOT_HALT;    // Emergency Stop
L   S5T#5S;           // Load for 5 seconds
SA  T   21;           // After pressing Emergency Stop
U   T   21;           //
=   "SPL".STOP_A_S;   // Intermediate marker STOP A for
                        // spindle C
//
U   "SPL".STOP_A_A;    // Intermediate marker STOP A for
                        // axes X,Z
UN  M   216.3;        // Test ext. STOP A (refer to FC 97)
=   "SPL".STOP_A_ABWA; // STOP A for axes X, Z
//
U   "SPL".STOP_A_S;    // Intermediate marker STOP A for
                        // spindle C
UN  M   216.3;        // Test ext. STOP A (refer to FC 97)
=   "SPL".STOP_A_ABWS; // STOP A for spindle C
//
U   "SPL".NOT_HALT;    // Emergency Stop signal internal
UN  M   216.2;        // Test ext. STOP C (refer to FC97)
=   "SPL".STOP_C_ABW; // De-select STOP C
//
UN  M   216.1;        // Test ext. STOP D (refer to FC97)
UN  M   216.7;        // STOP D for forced checking procedure
=   "SPL".STOP_D_ABW; // De-select STOP D
//
U   "SPL".NOT_HALT;    // Emergency Stop
=   "SPL".NOT_HALT1K; // Emergency Stop contactor
//
//
// ----- SBH de-selection using the key-operated switch -----
//
//
U   "SPL".SCHLUESSEL; // Key-operated switch
O   "SPL".TUERZUVER;  // DOOR CLOSED AND INTERLOCKED
=   "SPL".SBHABW;     // SBH de-selection
//
// ----- SG selection using the protective door -----
//
//
U   "SPL".TUERZUVER;  // DOOR CLOSED AND INTERLOCKED
=   "SPL".SG_BIT_0;   // SG bit 0
NETWORK
TITLE =supply of the SGE/SGA signals to/from the PLC-SPL
// Supply of conversion variables to axis data block

```

10.3 Safety Integrated with SPL

```

//
// Supply of SPL_DATA_OUTSEP ==> I/Os
//
U    "SPL".NOT_HALT1K; //
=    A    48.2;        // Emergency Stop contactor K4
//
// Supply SPL_DATA_OUTSIP ==> DB31, DB32, DB33
//
U    "SPL".STOP_A_ABWS; // Select STOP A for spindle C
=    DB33.DBX32.2;     // Drive interface for drive C
U    "SPL".STOP_A_ABWA; // Select STOP A for axis X
=    DB31.DBX32.2;     // Drive interface for drive X
=    DB32.DBX32.2;     // Drive interface for drive Z
//
U    "SPL".STOP_C_ABW; // Select STOP C for axes X, Z
=    DB31.DBX32.3;     // Drive interface for drive X
=    B32.DBX32.3;     // Drive interface for drive Z
=    DB33.DBX32.3;     // Drive interface for drive C
//
U    "SPL".STOP_D_ABW; // Select STOP D for axes X, Z
=    DB31.DBX32.4;     // Drive interface for drive X
=    DB32.DBX32.4;     // Drive interface for drive Z
=    DB33.DBX32.4;     // Drive interface for drive C
//
U    "SPL".SBHABW;     // SBH de-selection
=    DB31.DBX22.1;     // SBH de-selection, axis X
=    DB32.DBX22.1;     // SBH de-selection, axis X
=    DB33.DBX22.1;     // SBH de-selection, spindle C
//
U    "SPL".SG_BIT_0;  // SG bit 0 selection
=    DB31.DBX22.3;     // SG bit 0 axis X
=    DB32.DBX22.3;     // SG bit 0 axis Z
=    DB33.DBX22.3;     // SG bit 0 spindle C

NETWORK
TITLE = Terminal 663 ; AS1/AS2
U    DB31.DBX108.2;    // Pulses safely cancelled, axis X
U    DB32.DBX108.2;    // Pulses safely cancelled, axis Z
=    "SPL".KL_AS12_XZ; // Terminal AS1/AS2
=    "SPL".STAT_IMP_XZ; // Status, pulses cancelled
NOT ; //
=    "SPL".KL_663_XZ; // Terminal 663
=    "SPL".IMP_FREI_XZ; // Pulse enable X, Z
//
U    DB33.DBX108.2;    //
=    "SPL".KL_AS12_C; // Terminal AS1/AS2
=    "SPL".STAT_IMP_C; // Status, pulses cancelled
NOT ; //
=    "SPL".KL_663_C; // Terminal 663
=    "SPL".IMP_FREI_C; // Pulse enable C

```



```
//
END_FUNCTION
```

FUNCTION FC 97 : VOID

```

TITLE =Test stop
//Test stop activated after 8 hours have elapsed and the protective
door has been opened
VERSION : 0.1

BEGIN
NETWORK
TITLE =Test stop phase 1
//Forced checking procedure of the pulse cancellation

UN   M   211.0;           // Start monitoring time of 8 hours
L    S5T#2H40M;         // Load 2 hours and 40 minutes
SE   T    30;           // Start timer 30
//
U    T    30;           // After 2 hours and 40 minutes have
                        // elapsed
L    S5T#2H40M;         // Load 2 hours and 40 minutes
SE   T    31;           // Start timer 31
//
U    T    31;           // After 5 hours and 20 min. have elapsed
L    S5T#2H40M;         // Load 2 hours and 40 minutes
SE   T    32;           //
//
U    T    32;           // After 8 hours have elapsed and door not
UN   E    76.1;         // closed and interlocked
UN   DB31.DBX 108.2;    // Pulses not cancelled (X)
UN   DB32.DBX 108.2;    // Pulses not cancelled (Z)
UN   DB33.DBX 108.2;    // Pulses not cancelled (C)
U    DB31.DBX 110.5;    // Axis X stopped
U    DB32.DBX 110.5;    // Axis Z stopped
U    DB33.DBX 110.5;    // Axis C stopped
S    M    211.0;         // Reset monitoring time of 8 hours
S    M    211.1;         // Start test stop 1
//
CALL FC      60           // Test stop module
  start      := M 211.1,   // Start test stop 1
  reset      := E 3.7,     // Reset by RESET/MCP
  num_axis   := 2,        // Number of drives
  test_axis_1 := 1,       // Drive number, axis X
  test_axis_2 := 3,       // Drive number, spindle C
  test_axis_3 := 0,
  test_axis_4 := 0,
  test_axis_5 := 0,

```

10.3 Safety Integrated with SPL

```

test_axis_6 := 0,
test_axis_7 := 0,
test_axis_8 := 0,
servo_test_out := A 49.0, // Test stop 1 NCK by A49.0
aux_dword := 212, // Marker double word internal
ready := M 211.2, // Test stop 1 executed
error := M 211.7); // Error on test stop
//
U M 211.2; // Test stop 1 successfully executed
S M 211.3; // Start test stop 2
R M 211.2; // Test stop 1
//
CALL FC 60 (
start := M 211.3, // Start test stop 2
reset := E 3.7, // Reset by RESET/MCP
num_axis := 1, // 2 number of drives
test_axis_1 := 2, // Drive number axis Z
test_axis_2 := 0,
test_axis_3 := 0,
test_axis_4 := 0,
test_axis_5 := 0,
test_axis_6 := 0,
test_axis_7 := 0,
test_axis_8 := 0,
servo_test_out := A 49.1, // Test stop 2 NCK by A 49.1
aux_dword := MD 220, // Marker double word internal
ready := M 211.4, // Test stop 2 executed
error := M 211.6); // Error on test stop
//
U M 211.4; // Test stop 2 successfully executed
R M 211.1; // Start test stop 1
R M 211.3; // Start test stop 2
R M 211.4; // Test stop 2 successfully executed
S M 216.0; // Start test stop phase 2

NETWORK
TITLE =Test stop phase 2
// Forced checking procedure of external STOPs A and C
U M 216.0; // Start test stop phase 2
UN DB31.DBX 108.2; // Axis X: Pulses not safely cancelled
UN DB32.DBX 108.2; // Axis Z: Pulses not safely cancelled
UN DB33.DBX 108.2; // Spindle C: Pulses not safely cancelled
S M 216.1; // Initiate Stop D on the PLC side (FC96)
R M 216.0; // Reset, start test stop phase 2
//
U M 216.1; // Check Stop D on the PLC side
U DB31.DBX 111.6; // STOP D active, axis X

```

```

U   DB32.DBX 111.6;           // STOP D active, axis Z
U   DB33.DBX 111.6;           // STOP D active, spindle C
S   M   216.2;                 // Initiate Stop C on the PLC side (FC96)
R   M   216.1;                 // Reset check, Stop D (PLC)
//
U   M   216.2;                 // Check Stop C on the PLC side
U   DB31.DBX 111.5;           // STOP C active, axis X
U   DB32.DBX 111.5;           // STOP C active, axis Z
U   DB33.DBX 111.5;           // STOP C active, spindle C
S   M   216.3;                 // Initiate Stop A on the PLC side (FC96)
R   M   216.2;                 // Reset check, Stop D (PLC)
//
U   M   216.3;                 // Check Stop A on the PLC side
U   DB31.DBX 111.4;           // STOP A/B active, axis X
U   DB32.DBX 111.4;           // STOP A/B active, axis Z
U   DB33.DBX 111.4;           // STOP A/B active, spindle C
S   M   216.4;                 // Check: STOP A (PLC) not active
R   M   216.3;                 // Reset check, Stop A (PLC)
U   M   216.4;                 // Check: STOP A (PLC) not active
UN  DB31.DBX 111.4;           // STOP A/B not active, axis X
UN  DB32.DBX 111.4;           // STOP A/B not active, axis Z
UN  DB33.DBX 111.4;           // STOP A/B not active, spindle C
S   M   216.5;                 // Initiate Stop D on the NCK side
R   M   216.4;                 // Reset check: STOP A (PLC)
//
U   M   216.5;                 // Initiate Stop D on the NCK side
=   A   49.4;                 // See circuit diagram and NCK-SPL
//
U   M   216.5;                 // Check Stop D on the NCK side
U   DB31.DBX 111.6;           // STOP D active, axis X
U   DB32.DBX 111.6;           // STOP D active, axis Z
U   DB33.DBX 111.6;           // STOP D active, spindle C
S   M   216.6;                 // Initiate Stop C on the NCK side
R   M   216.5;                 // Reset check: Stop D (NCK)
//
U   M   216.6;                 // Initiate Stop C on the NCK side
=   A   49.3;                 // See circuit diagram and NCK-SPL
U   M   216.6;                 // Check Stop C on the NCK side
U   DB31.DBX 111.5;           // STOP C active, axis X
U   DB32.DBX 111.5;           // STOP C active, axis Z
U   DB33.DBX 111.5;           // STOP C active, spindle C
S   M   216.7;                 // Initiate Stop A on the NCK side
R   M   216.6;                 // Reset check: Stop C (NCK)
//
U   M   216.7;                 // Initiate Stop A on the NCK side
=   A   49.2;                 // See circuit diagram and NCK-SPL
//

```

10.3 Safety Integrated with SPL

```

U    M    216.7;           // Check Stop A on the NCK side
U    DB31.DBX 111.4;      // STOP A/B active, axis X
U    DB32.DBX 111.4;      // STOP A/B active, axis Z
U    DB33.DBX 111.4;      // STOP A/B active, spindle C
S    M    217.0;           // Check: STOP A (NCK) not active
R    M    216.7;           // Reset check: Stop A (NCK)
//
U    M    217.0;           // Check: STOP A (NCK) not active
UN   DB31.DBX 111.4;      // STOP A/B not active, axis X
UN   DB32.DBX 111.4;      // STOP A/B not active, axis Z
S    M    217.1;           // Start forced checking proced. at inputs
R    M    217.0;           // Reset check: STOP A (NCK)
//

NETWORK
TITLE =Forced checking procedure of the input and output devices
// The time to perform the forced checking procedure can depend on several
// machine-specific conditions. The solution shown in this example is not
// binding.
//
U    M    217.1;           // Start forced checking proc. for M217.1=1
U    "SPL".NOT_HALT;      // Emergency Stop not actuated
S    M    218.0;           // Check Emergency Stop inputs
R    M    217.1;           // Reset: Start forced checking procedure
R    A    48.1;           // PLC forced checking procedure output
//
U    M    218.0;           // Check Emergency Stop inputs
L    S5T#120MS;           // Drop-out time of contactor
SE   T    22;             // Timer 22
//
U    T    22;             // After drop-out time of contactor
UN   A    48.1;           // PLC forced checking procedure output
UN   E    76.4;           // Error, feedback contactor input = 0
S    M    218.7;           // Initiate Stop D (refer to FC96)
S    A    48.1;           // PLC forced checking procedure output
//
U    T    22;             // After drop-out time of contactor
U    A    48.1;           // PLC forced checking procedure output
U    E    76.4;           // Good case, feedback contactor input = 1
S    M    218.1;           // Start acknowledge
S    A    48.1;           // PLC forced checking procedure output
R    M    218.0;           // Check Emergency Stop inputs
//
U    T    22;             // After drop-out time of contactor
U    E    3.7;            // RESET MCP
U    E    76.0;           // Emergency Stop (PLC) not actuated
U    E    76.4;           // Forced checking procedure input E76.4=1
S    M    218.1;           // Start acknowledge

```

```

R    M    218.0;           // Check Emergency Stop inputs
R    M    218.7;           // Withdraw Stop D
//
U    M    218.1;           // Start acknowledge
L    S5T#50MS;            // Delay time for Emergency Stop inputs
SE   T    23;              // Set timer 23
//
UN   E    76.0;           // Emergency Stop actuated
     M    218.1;           // Reset acknowledge
//
U    T    23;              //
U    E    76.0;           // Emergency Stop not actuated
U    E    76.4;           // Forced checking procedure input E76.4=1
S    "SPL".QUIT_MARKER;  // Acknowledge Emergency Stop PLC
S    M    218.2;           // Acknowledge Emergency Stop NCK
R    M    218.1;           // Check: Emergency Stop
R    T    23;              // Reset timer 23
//
U    "SPL".QUIT_MARKER;  // Acknowledge Emergency Stop PLC
L    S5T#200MS;           // Delay time: Acknowledge NCK/PLC
SE   T    24;              // Set timer 24
//
U    T    24;              // Acknowledge Emergency Stop
S    M    218.3;           // Withdraw acknowledge NCK
R    M    218.2;           // Acknowledge Emergency Stop NCK
R    T    24;              // Reset timer 24
//
UN   M    218.2;           // Acknowledge Emergency Stop NCK
SPB  QUI1;                 // Do not acknowledge NCK
//
L    1;                    // Load 1
T    MB  194;              // Transfer marker byte 194
//
QUI1: UN M 218.3;          // Withdraw acknowledge NCK
     SPB          QUI2;    //
//
L    0;                    // Load 0
T    MB  194;              // Transfer marker byte 194
//
QUI2: NOP    0;           //
//
//
CALL FC 21 (              //
  Enable    := "SPL".QUIT_MARKER,
  Funct     := B#16#4,
  S7Var     := P#M 194.0 BYTE 1,
  IVAR1     := -1,

```

10.3 Safety Integrated with SPL

```

Error      := M 218.4,
ErrCode   := MW 188);
//
U    M    218.3;           // Withdraw acknowledge NCK
U    "SPL".NOT_HALT;      // Acknowledge Emergency Stop PLC o.k.
UN   DB18.DBX 110.1;      // No difference between NCK/PLC
UN   M    218.4;           // No error during transfer
R    "SPL".QUIT_MARKER;   // Acknowledge Emergency Stop PLC
R    M    218.3;           // Reset: Withdraw acknowledge NCK
R    M    211.0;           // Start monitoring time of 8 hours

END_FUNCTION

```

10.3.12 Appendix

Excerpt from symbol table

	Symbol	Address	Data type	Comment
1	Run-up_ASUB_Start	M 210.0	BOOL	Run-up marker for SPL/ASUB start
2	Flanke_FB4_SPL_Start	M 210.1	BOOL	Edge marker for SPL/FB4 start
3	Zyklus_FB4_SPL_Start	M 210.2	BOOL	Cycle marker for SPL/FB4 start
4	FB4_Start	M 210.3	BOOL	Interrupt number and polarity for SPL (FB4)
5	FC9_SPL_Start	M 210.4	BOOL	Start SPL
6	Teststop_aktiv	M 211.0	BOOL	Activate test stop
7	Teststop_1_starten	M 211.1	BOOL	Forced checking procedure of the shutdown paths (X, C)
8	Teststop_1_ready	M 211.2	BOOL	Test stop 1 performed without errors
9	Teststop_2_starten	M 211.3	BOOL	Forced checking procedure of shutdown paths (Z)
10	Teststop_2_ready	M 211.4	BOOL	Test stop 2 performed without errors
11	Teststop_2_error	M 211.6	BOOL	Error for test stop 2 (Z)
12	Teststop_1_error	M 211.7	BOOL	Error for test stop 1 (X, C)
13	QUIT_NCK_error	M 214.4	BOOL	Error for transfer using FC21
14	Teststopphase_2_starten	M 216.0	BOOL	Start test of external stops
15	Test_Stop_D_PLC	M 216.1	BOOL	Trigger Stop D in PLC/FC96
16	Test_Stop_C_PLC	M 216.2	BOOL	Trigger Stop C in PLC/FC96
17	Test_Stop_A_PLC	M 216.3	BOOL	Trigger Stop A in PLC/FC96
18	PLC_Stop_A_nicht_aktiv	M 216.4	BOOL	Stop A/PLC check not active
19	Test_Stop_D_NCK	M 216.5	BOOL	Trigger Stop D via A 49.4/PLC in NCK

	Symbol	Address	Data type	Comment
20	Test_Stop_C_NCK	M 216.6	BOOL	Trigger Stop C via A 49.3/PLC in NCK
21	Test_Stop_A_NCK	M 216.7	BOOL	Trigger Stop A via A 49.2/PLC in NCK
22	NCK_Stop_A_nicht_aktiv	M 217.0	BOOL	Stop A/NCK check not active
23	Test_I/O_Peripherie_1	M 217.1	BOOL	Forced checking procedure of the I/O devices
24	Test_I/O_Peripherie_2	M 218.0	BOOL	Check Emergency Stop inputs
25	Test_I/O_Peripherie_3	M 218.1	BOOL	Start acknowledgment for Emergency Stop
26	Test_I/O_Peripherie_4	M 218.2	BOOL	Acknowledge Emergency Stop on the NCK side
27	Test_I/O_Peripherie_5	M 218.3	BOOL	Withdraw Emergency Stop acknowledge on the NCK side
28	Fehler_Stop_D_PLC	M 218.7	BOOL	Feedback input of contactors E 76.4 not o.k.
29	Teststop_1_intern	MD 212	DWORD	Run test stop 1 FC60 internal
30	Teststop_2_intern	MD 220	DWORD	Run test stop 2 FC60 internal
31	QUIT_NCK_error_code	MW 188	WORD	Error code from FC21
32	TIMER1	T 20	TIMER	STOP C → STOP A (axes)
33	TIMER2	T 21	TIMER	STOP C → STOP A (spindle)
34	T_K_ABFALL	T 22	TIMER	Drop-out time of the contactors K1, K2
35	T_VERZUG_1	T 23	TIMER	Delay time for Emergency Stop input
36	T_VERZUG_2	T 24	TIMER	Acknowledgment delay time
37	Teststop_Zeit_1	T 30	TIMER	Monitoring duration 2h 40 min
38	Teststop_Zeit_2	T 31	TIMER	Monitoring duration 5h 20 min
39	Teststop_Zeit_3	T 32	TIMER	Monitoring duration 8h

Symbols used in the PLC program

The following structure was used for the PLC program of the configuration example.

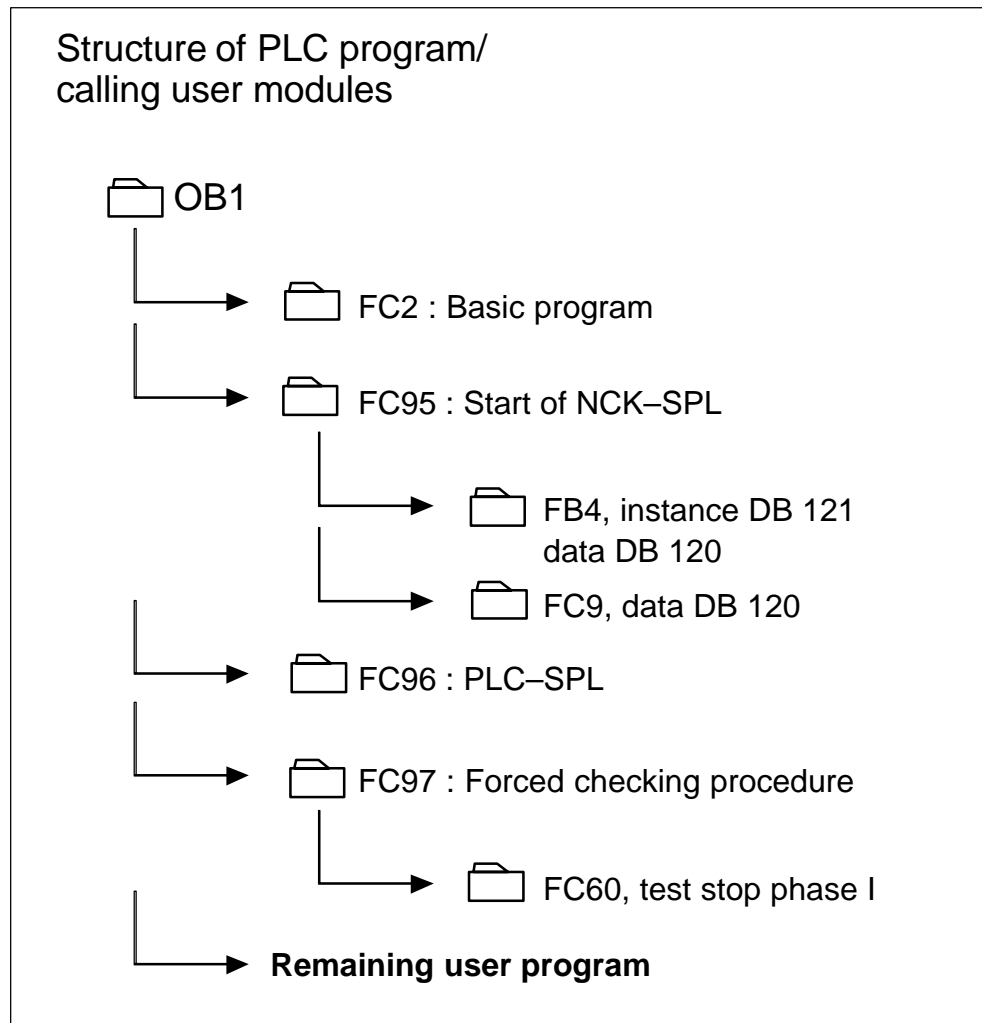

Fig. 10-19 Structure of the user program

The following function overview is used to configure and commission SPL logic.

Function overview SPL logic

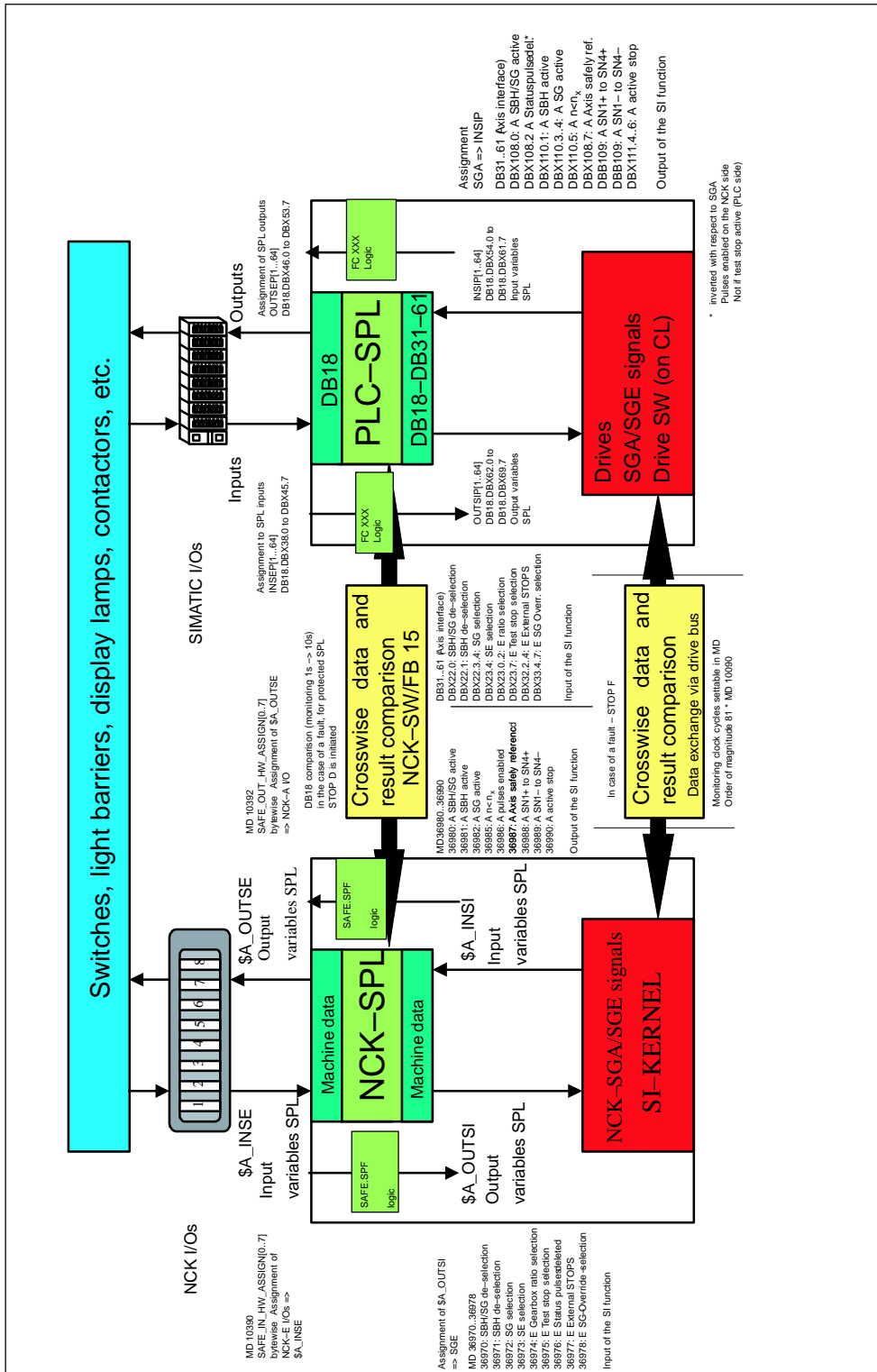

Fig. 10-20 Overview of SPL logic

10.4 Safety Integrated without SPL

Contrary to Safety Integrated with SPL, in this case the program (Step7 PLC program) must be emulated for the NCK using switches and contactors. This has an impact on the costs associated with the cabinet wiring, and, depending on the complexity of the machine, is complicated. In addition, the Emergency Stop buttons and the door switches must be evaluated by safety contactors which themselves influence the drives of the 611digital group.

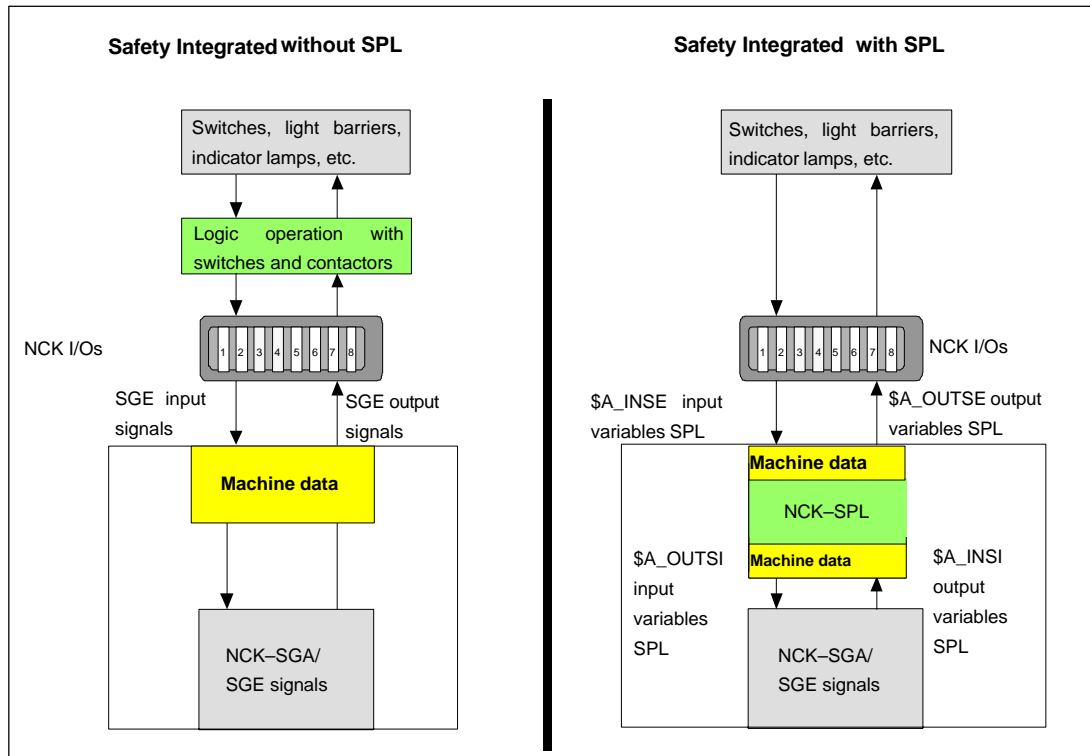

Fig. 10-21 Function schematic of SI without SPL

10.4.1 Connecting-up the drives

The drives are connected-up exactly in the same way as for the version with SPL. Pulse enable (terminal 663) and the feedback regarding the status of the pulses (AS1/AS2) are assigned to the NCK-SGE via machine data.

X axis:

36986 SAFE_PULSE_ENABLE_OUTPUT : 01040203H
 36976 SAFE_PULSE_STATUS_INPUT : 01040107H

Z axis:

36986 SAFE_PULSE_ENABLE_OUTPUT : 01040203H
 36976 SAFE_PULSE_STATUS_INPUT : 01040107H

Spindle C:
 36986 SAFE_PULSE_ENABLE_OUTPUT : 01040204H
 36976 SAFE_PULSE_STATUS_INPUT : 01040108H

Power can be supplied to terminal AS1 either from terminal 9 or an external +24 V power supply, depending on the cabinet configuration.

On the PLC side, the pulses must be enabled on the axis-specific drive interface (DB3x.DBX21.7).

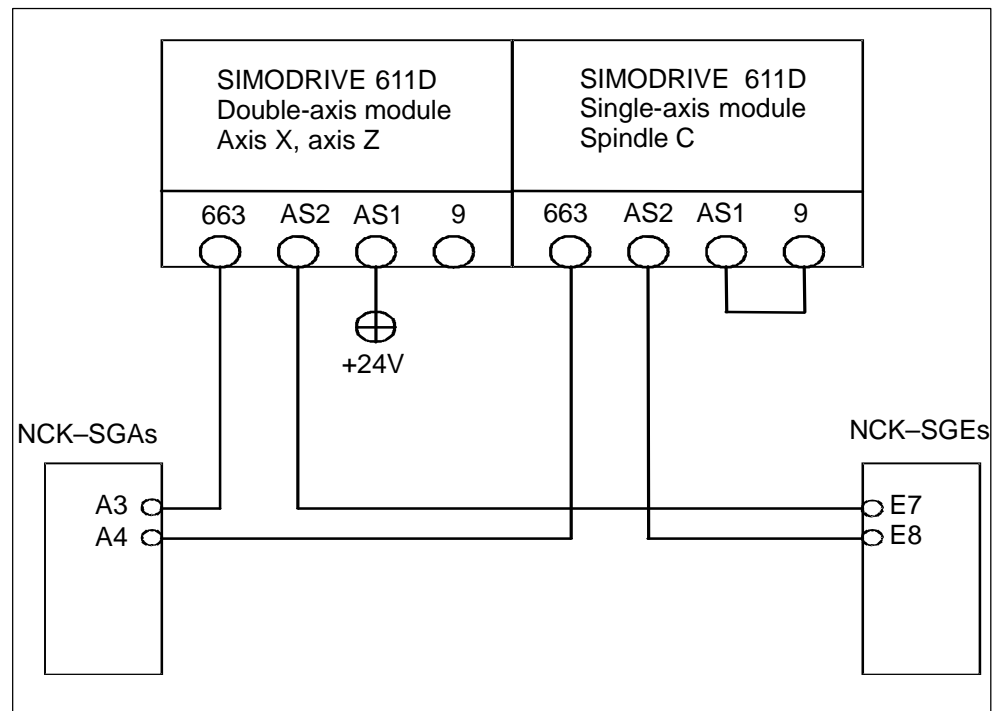

Fig. 10-22 Circuit example

10.4.2 Emergency Stop and connecting-up the I/R module

For an Emergency Stop, all the drives in the drive group are stopped via terminal 64 (controller inhibit) on the infeed/regenerative feedback module.

The drives brake with the maximum current (this can be configured).

After a certain delay (if, for example, the spindle has also braked and is stationary), the internal line contactor in the NE module, that is used to electrically isolate it from the power supply, is opened via terminal 48 (DIN EN 60204-1). The connection between terminals NS1, NS2 is opened as an additional safety measure to prevent the line contactor from re-closing.

The infeed/regenerative feedback module is connected to the line supply using a three-conductor cable.

The line contactor integrated in the infeed/regenerative feedback module is used to isolate the drives from the line supply. (an external line contactor is not required).

10.4 Safety Integrated without SPL

Circuit diagram

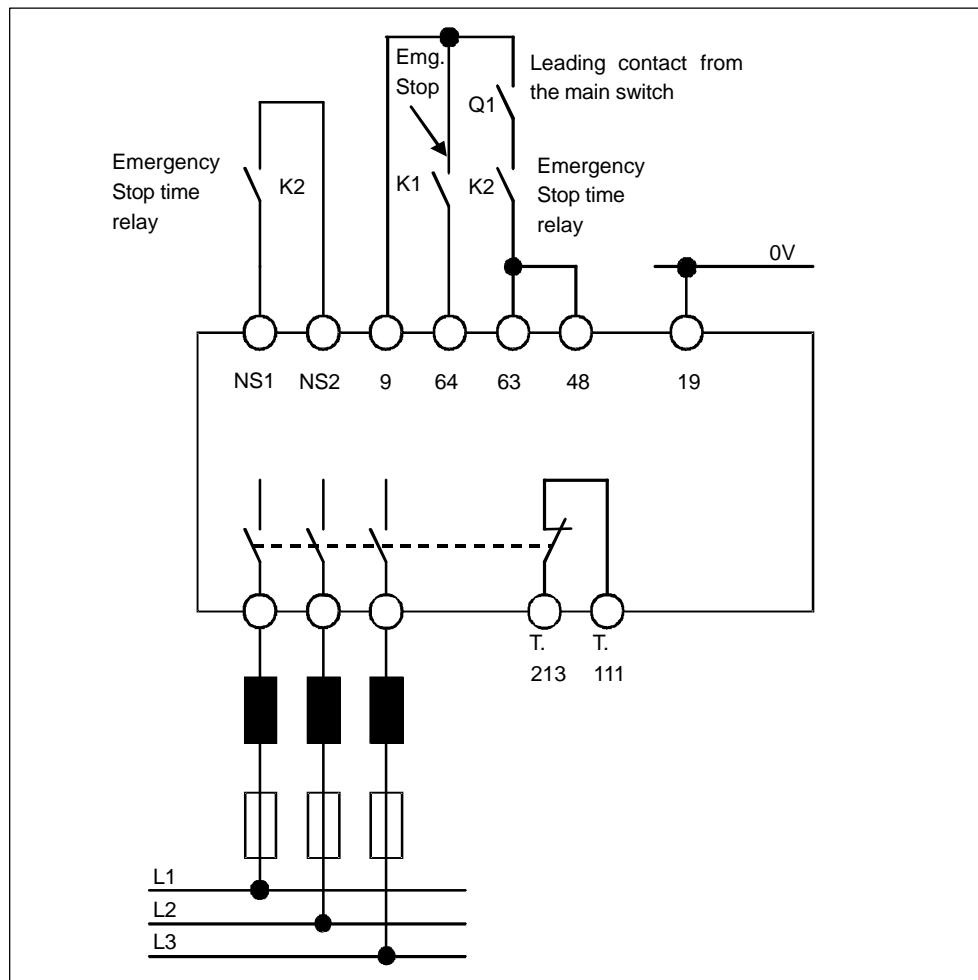

Fig. 10-23 Connecting-up the infeed/regenerative feedback module without SPL

The Emergency Stop button is monitored using a safety relay K1 (3TK2805). When the Emergency Stop button is pressed, safety relay K1 drops-out immediately and opens the NO contacts that are in the circuit between terminal 9 and terminal 64 on the infeed/regenerative feedback module and in the path to supply delay module 3TK29.

As soon as the selected delay time has elapsed, delay module K2 (3TK29.3) also drops-out and opens the NO contacts that are in the circuit between terminal 9 and terminal 48/63 and in the circuit between terminal NS1 and terminal NS2. Emergency Stop can only be acknowledged when the line contactor in the infeed/regenerative feedback module and the delay module K2 have dropped-out.

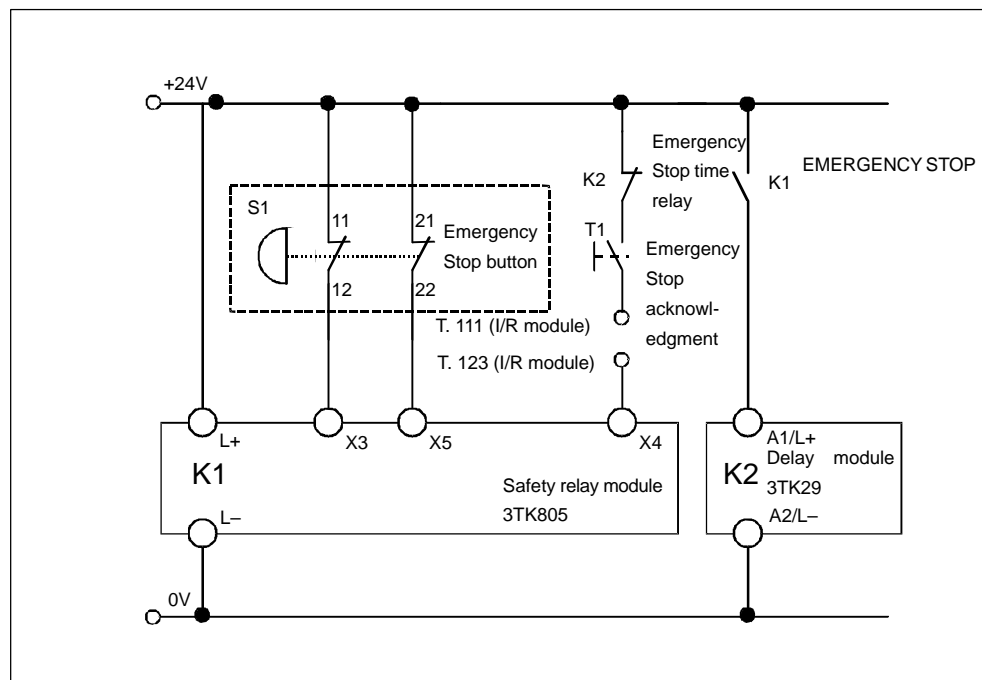

Fig. 10-24 Connecting-up the safety relay combination

10.4.3 Test stop

For the test stop, the first section of the test stop test can be taken from the PLC programming example with SPL. The parameterization of the machine data is directly referred to the DMP input modules:

X axis:	36975	SAFE_STOP_REQUEST_INPUT	: 01060809H
Spindle C:	36975	SAFE_STOP_REQUEST_INPUT	: 01060809H
Z axis:	36975	SAFE_STOP_REQUEST_INPUT	: 0106080AH

Circuit diagram

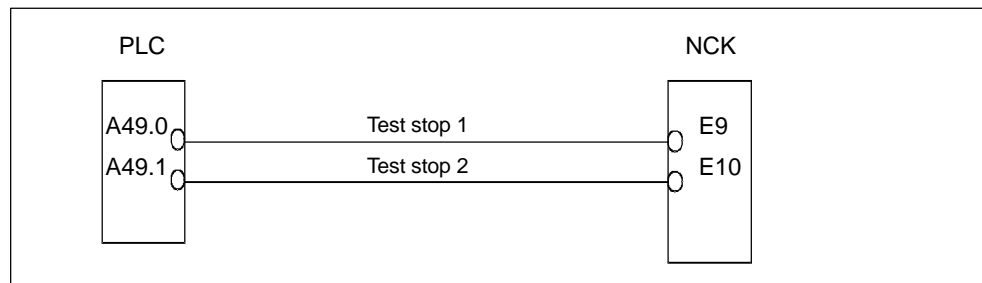

Fig. 10-25 Circuit diagram for test stop

10.4.4 Protective door interlocking

The following circuit is used to monitor the protective door if external devices (hydraulics, cooling water etc.) have to be powered-down/disconnected when the door is opened. The safety relay monitors the door switch and its contacts are included in the switching logic for the SGEs of the Safety Integrated functions. Other contacts of the safety contactor switch all of the external devices (not included in this example) in the vicinity of the protective door that are potentially hazardous to personnel.

If the protective door switch only activates and de-activates Safety Integrated functions of the NC drives in the safety area, and this is clearly confirmed by the risk analysis, then the contacts of the door switch can be directly integrated into the switching logic for the SGEs (NCK/PLC) (refer to Fig. 10-26). Safety Integrated monitors the door switch using the crosswise data comparison of the SGEs.

Circuit diagram

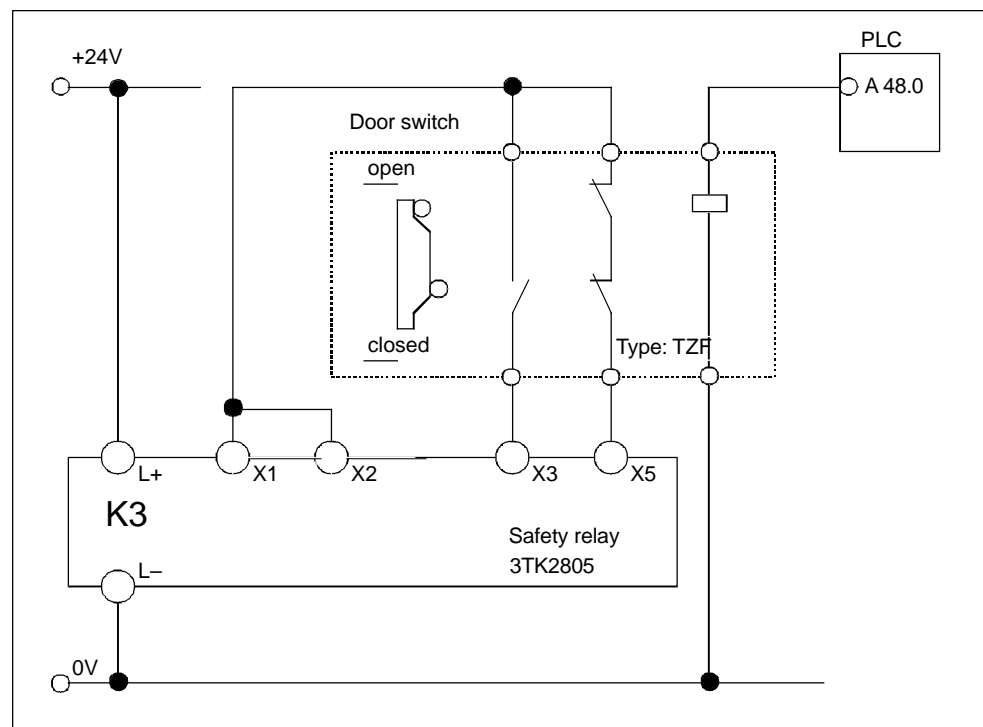

Fig. 10-26 Circuit diagram for the protective door interlocking

We recommend a door release solenoid whose mechanical system (as shown) acts on the contacts of the feedback signals.

The protective door interlocking functions so that when the protective door is open terminal X3 of the safety relay is energized and when the door is closed terminal X5 of the safety relay is energized.

10.4.5 De-selecting SBH using the key-operated switch/SG change-over using the door safety contactor

On the NCK side, "safe operating stop" is de-selected using DMP input 5. The state shown in the circuit diagram is "protective door open" and "safe operating stop" was selected using the key-operated switch. Using the key-operated switch, it is possible to change-over to safely-reduced speed with the protective door open.

X axis, Z axis, spindle C:

36971 SAFE_SAFE_SS_DISABLE_INPUT: : 01040105H

Safe operating stop is de-selected when the protective door is closed and a changeover is made from safely-reduced speed 1 (personnel protection) to safely-reduced speed 2 (machine protection).

X axis, Z axis, spindle C:

36972 SAFE_SAFE_VELO_SELECT_INPUT[0] : 01040106H

On the PLC side, the switching states of the door and the key-operated switch are logically combined in an S7 program. The safety functions are activated and de-activated via the PLC drive interface (refer to Chapter 6.4, "Interface signals").

Circuit diagram

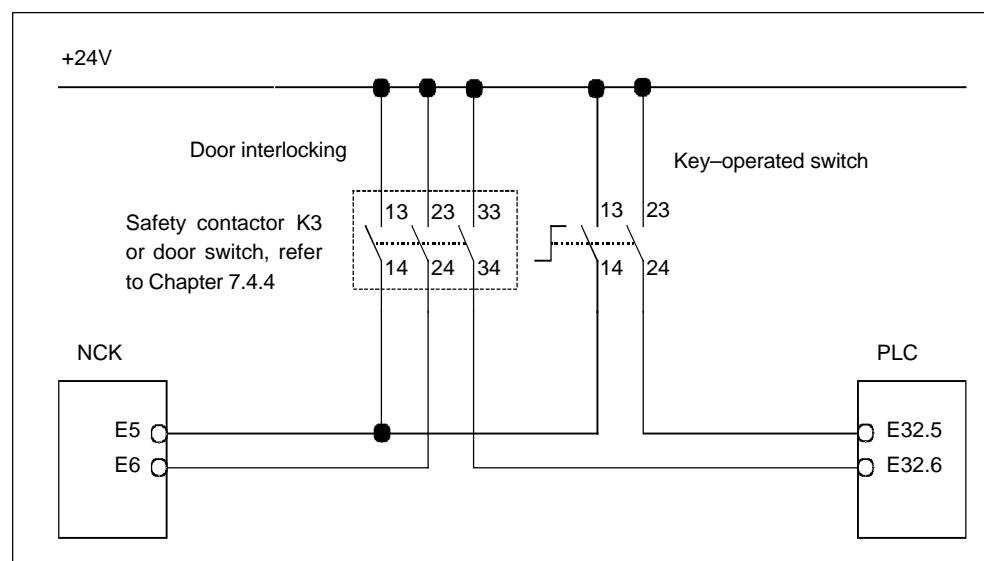

Fig. 10-27 Circuit diagram: SBH de-selection using a key-operated switch
SG changeover using the door safety contactor

10.4 Safety Integrated without SPL**Program****Program excerpt:**

```
//  
// -- SBH selection using the protective door and using the key-  
// operated switch --  
U    E    32.5          // Door closed and interlocked  
O    E    32.6          //  
=    DB31.DBX22.1      // SBH de-selection  
=    DB32.DBX22.1      // SBH de-selection  
=    DB33.DBX22.1      // SBH de-selection  
  
//  
// ----- SG selection using the protective door -----  
//  
U    E    32.6          // Door closed and interlocked  
=    DB31.DBX22.3      // SG bit 0  
=    DB32.DBX22.3      // SG bit 0  
=    DB33.DBX22.3      // SG bit 0
```

10.5 External STOPS

Description

This example is based on the configuring example in Chapter 7, "Safety Integrated without SPL", although external STOP C is to be used for all the drives on the example machine. A small SPL program has to be written for this problem because external STOP A must be supplied from a system variable (\$A_OUTSI). In this case, the hardware of the NCK-SPL does not have to be assigned using the machine data 10390/10392; neither does the machine data parameterized in Chapter 10.4 "Safety Integrated without SPL" have to be changed.

Task/structure:

An external STOP C is to be activated for X, Z, C when the light barrier is triggered. The light barrier is analyzed by an external unit. The light barrier is also acknowledged by a switch that is connected to this evaluation unit. In order to test the external STOP C the two switching contacts for the PLC I/Os and the NCK I/Os are supplied with +24 V from two separate PLC outputs (A36.0/A36.1) (refer to the circuit diagram).

The logical drive number for the terminal block is 4 and the input module used is inserted into slot 1 in the terminal block.

Commissioning is now explained step-by-step with reference to the previous sections in Chapter 7.

1. Enable the function "SBH/SG monitoring" and "external STOPS" for drives X, Z, C using the axis-specific machine data
36901: SAFE_FUNCTION_ENABLE = 41 H
2. Set machine data 11602: ASUP_START_MASK=7: ASUB start in all operating states of the NC (RESET/JOG/not all axes referenced/read-in inhibit active).
3. Set machine data 11604: ASUP_START_PRIO_LEVEL=1: (interrupt priority from which MD \$MN_ASUP_START_MASK is active).
4. Enter axis-specific machine data for drives X, Z, C
36977:
SAFE_EXT_STOP_INPUT[0]: 04010101H (STOP A is supplied from \$A_OUTSI[1] in the SPL)
36977:
SAFE_EXT_STOP_INPUT[1]: 01040101H (first input on the DMP input module)
36977
SAFE_EXT_STOP_INPUT[2]: 80000000H (STOP D statically de-selected).
5. The other safety machine data are parameterized as described in Chapter 7, "Safety Integrated without SPL".

10.5 External STOPs

6. The following program has to be written for the PLC:

```

SET
  = DB18.DBX62.0 // Supply OUTSIP[1]
  = DB31.DBX32.2 // Supply STOP A for axis X
  = DB32.DBX32.2 // Supply STOP A for axis Z
  = DB33.DBX32.2 // Supply STOP A for spindle C
//
U   E   32.0 // PLC input/light barrier evaluation unit
  = DB31.DBX32.3 // Supply STOP C for axis X
  = DB32.DBX32.3 // Supply STOP C for axis Z
  = DB33.DBX32.3 // Supply STOP C for spindle C
//
SET
  = DB31.DBX32.4 // Supply STOP D for axis X
  = DB32.DBX32.4 // Supply STOP D for axis Z
  = DB33.DBX32.4 // Supply STOP D for spindle C

```

7. In addition, in the automatic mode, if the light barrier is interrupted, the PLC should trigger an NC–STOP at the channel interface.

8. Implement the following NCK–SPL in the standard cycle directory CST.DIR under the name SAFE.SPF

```

%_N_SAFE_SPF
; $PATH=/_N_CST_DIR) .
; SAFE_CHECKSUM = 000009C6H
;
N100 IDS=01 DO $A_OUTSI[1] = 1 // Static de-selection STOP A
;
N110 M17

```

9. The NCK–SPL start when the control runs–up is described in Chapter 7, "Starting the NCK–SPL and PLC–SPL".

10. The first part of the test stop described in Chapter 7, "Test stop", can be used and adapted to the machine configuration. An external STOP C must be incorporated in each test algorithm in the following form:

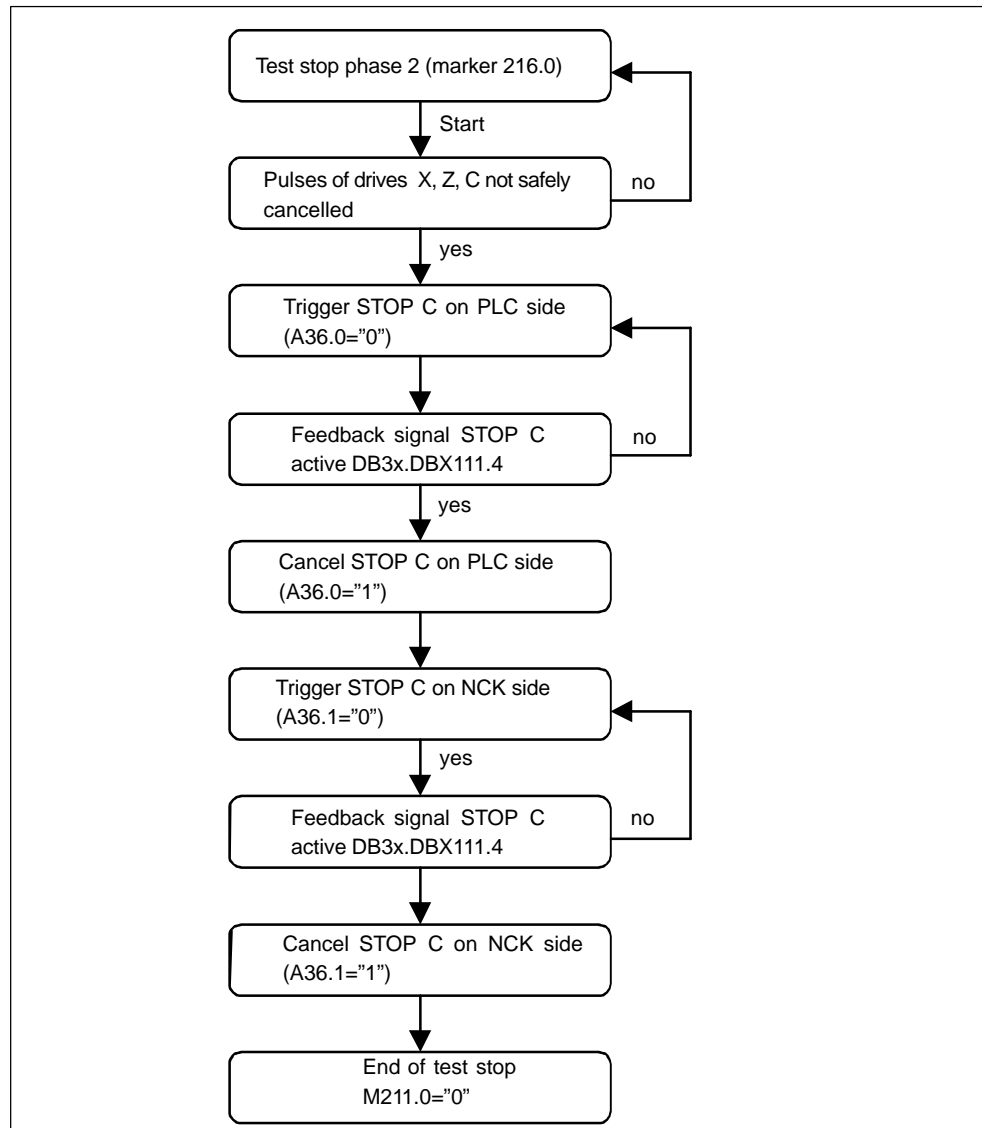

Fig. 10-28 Flowchart when testing an external STOP C

Circuit diagram

Fig. 10-29 Connecting-up

Note

The drive cannot be operated until the SPL is started because the external STOP A is not supplied!

10.6 Application example with PROFIsafe connection

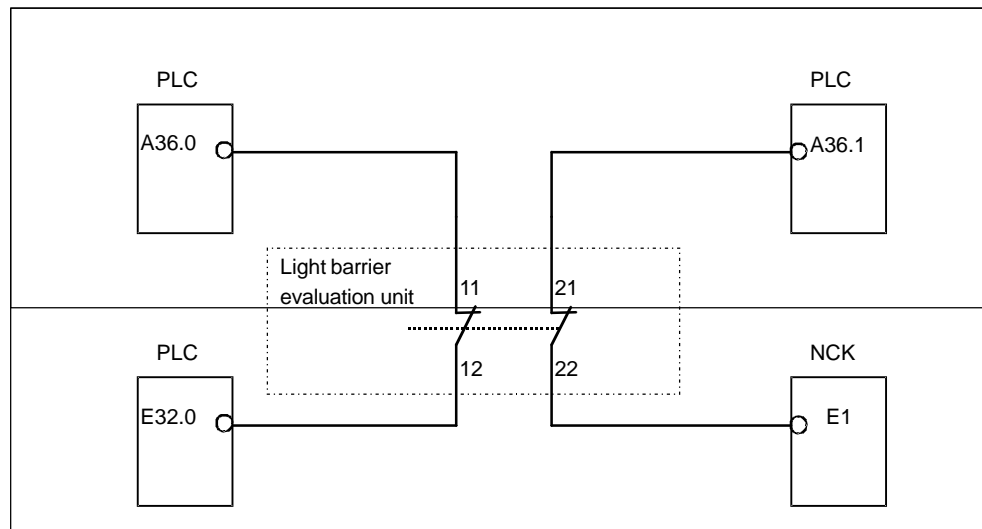
The following functional elements will be described using this example:

- Wiring options for ET 200S PROFIsafe modules
- Parameterizing the ET 200S PROFIsafe components (hardware configuration)
- Parameterizing the associated machine data
- Effects on the NCK and PLC–SPL (safe programmable logic)

The entire system with all of the required hardware and software settings is not shown; instead, only the sections that differ when compared to previous SPL applications with two separate hardware I/O branches (NCK and PLC I/Os).

For the ET 200S modules used, only the data essentially required for the application is described. A detailed description should be taken from the appropriate product manuals.

10.6.1 Software prerequisites

When engineering the hardware of the ET 200S components, we recommend that the ET 200S configurator is used. This is part of the electronic Siemens CA 01 Catalog (SIMATIC selection tool).

The applications are based on the following system software versions:

- NCU system software Version \geq 06.04.15
- STEP 7 software Version \geq 05.02
- F–Configuration Pack Version \geq 05.03
This expansion for STEP 7 is required in order to be able to configure the PROFIsafe modules in the hardware configuration.

10.6.2 Functional scope of the application

The safety–related input signals read–in through the F–DI module and processed in the SPL are to be used to change–over axis–specific safety functions (SBH, SG, external stop responses, etc.) and output safety–related output signals to actuators (via an F–DO module or a PM–E F module).

Further, safety–related motor starters are controlled through an PM–D F module.

10.6.3 Connecting-up the sensors and actuators

Design and structure of the ET 200S line-up used in the example

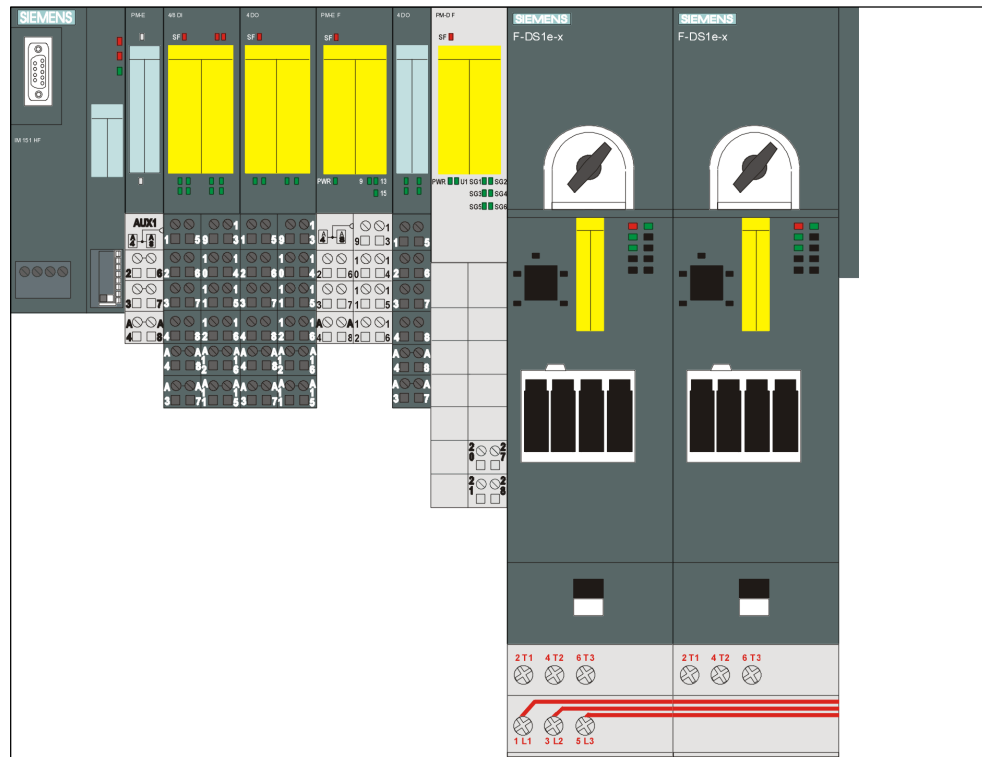

Fig. 10-30 Design and structure of the DP slave

10.6.4 Parts list for the configured ET 200S line-up

Table 10-1 Parts list, ET 200S line-up

Order No.	Designation	Quantity
3RK130-0BB13-0AA2	Fail-safe direct starter; 2.4 to 8 A	2
3RK1903-3AA00	Terminal module for power module PM-D F	1
3RK1903-3AC00	Terminal module for direct starter F with feeder connection	1
3RK1903-3AC10	Terminal module for direct starter F without feeder connection	1
3RK1903-3BA00	Power module PM-D F PROFIsafe	1
6ES7138-4BD00-0AA0	Electronics module 4DO, DC 24 V/0.5 A, standard (5 units)	0.2
6ES7138-4CA00-0AA0	Power module PM-E, DC 24 V for electronic modules with diagnostics	1
6ES7138-4CF00-0AB0	Power module PM-E F PROFIsafe, DC 24 V	1
6ES7138-4FA00-0AB0	Electronic module 4/8F-DI, DC 24 V, PROFIsafe (1 unit)	1

Table 10-1 Parts list, ET 200S line-up, continued

Order No.	Designation	Quantity
6ES7138-4FB00-0AB0	Electronics module, 4F-DO, DC 24 V/2 A, PROFISAFE (1 unit)	1
6ES7151-1BA00-0AB0	IM 151 High Feature to connect the ET 200S to PROFIBUS DP	1
6ES7193-4CA40-0AA0	Universal terminal module; screw connection (5 units)	0.2
6ES7193-4CD20-0AA0	Terminal module to AUX1 infeed; screw connection	1
6ES7193-4CF40-0AA0	Terminal module for the electronics module 30 mm; screw terminal; AUX1	2
6ES7193-4CK20-0AA0	Terminal module PROFIsafe; screw terminals	

The configuring guidelines of ET 200S are applicable (refer to the Manual "Distributed ET 200S I/O system"). When using an ET 200S slave for the first time, it must be ensured that the ET 200S line-up (started using the IM151-HF) is correctly terminated using a connection module. If the line-up is not correctly terminated, then PROFIBUS communications will not be possible.

10.6.5 Signal assignment and significance

The signal assignment and significance (a part of) will now be subsequently explained for the PROFIsafe modules:

Electronics module 4/8 F-DI DC24V PROFIsafe

The safety-related I/O input signals are connected to this module. These are either implemented using two NC contacts (Emergency Stop actuator and interlocking status, protective door) using an exclusive OR function. This means with one NC contact and one NO contact (agreement button) or with two NO contacts (<drives on>button). As a result of these versions, in some cases, different parameter settings are obtained in the hardware configuration under STEP 7.

All of the sensor signals are connected through two channels.

10.6 Application example with PROFI-safe connection

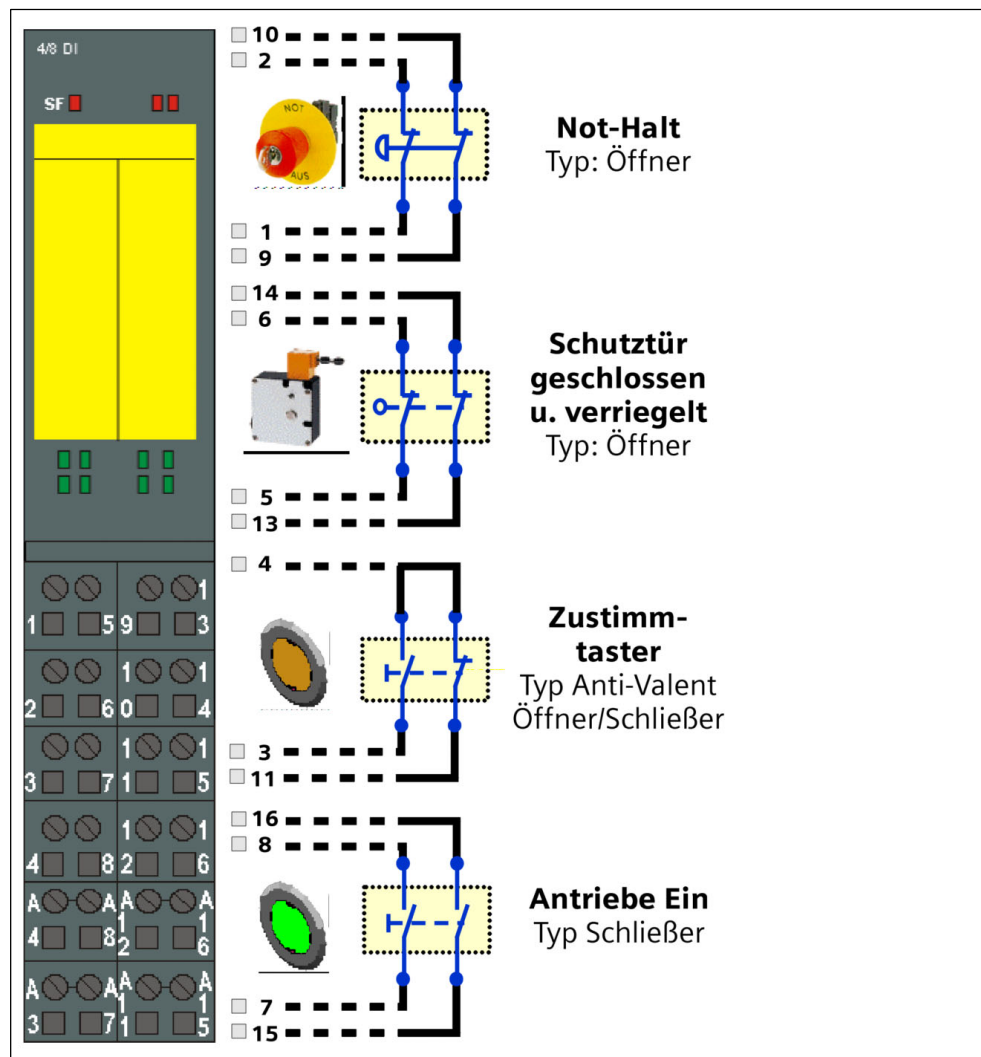

Fig. 10-31 Signal assignment, electronics module, 4/8F-DI, DC 24 V, PROFI-safe

Significance and use of the individual signals:

F-DI terminal 1 (channel 0), terminal 9 (channel 4)

Emergency Stop actuator

Signal status, channel 0 = "1" and channel 4 = "1":

Emergency Stop actuator not pressed

Signal status, channel 0 = "0" and channel 4 = "0":

Emergency Stop actuator pressed

F-DI terminal 5 (channel 1), terminal 13 (channel 5)

Interlocking status, protective door

The door switch only interlocks if the actuator is inserted. The contacts of the monitoring circuit then signal the status "closed and interlocked"

Signal status, channel 1 = "1" and channel 5 = "1":
Protective door closed and interlocked

Signal status, channel 1 = "0" and channel 5 = "0":
Protective door not closed and not interlocked

F–DI terminal 3 (channel 2), terminal 11 (channel 6)

Agreement button

Signal status, channel 2 = "1" and channel 6 = "0"
Agreement button pressed

Signal status, channel 2 = "0" and channel 6 = "1"
Agreement button not pressed

F–DI terminal 7 (channel 3), terminal 15 (channel 7)

<Drives ON> button

Signal status, channel 3 = "0" and channel 7 = "0"
Button <drives on> not pressed

Signal status, channel 3 = "1" and channel 7 = "1"
Button <drives on> pressed

VS1: Internal encoder supply for channels 0 to 3

VS2: Internal encoder supply for channels 4 to 7

These two encoder supplies must be used if the short–circuit test is activated (refer to Chapter 10.6.7 Configuring and wiring the ET 200S I/O> components of the device IM151 HF: F–DI module).

The **exclusive OR** sensor, **agreement button** represents an exception. For this sensor version, in conjunction with the **short–circuit test**, encoder supply VS1 must be used for both contacts.

Electronics module 4 F–DO DC24 V/2 A PROFIsafe

The actuators that must be shut–down in a safety–related fashion are connected through two channels. Each output channel can be separately shutdown.

Two valve units are connected in the configuration example. These are used to control the motion of the supplementary pneumatic axis.

10.6 Application example with PROFI-safe connection

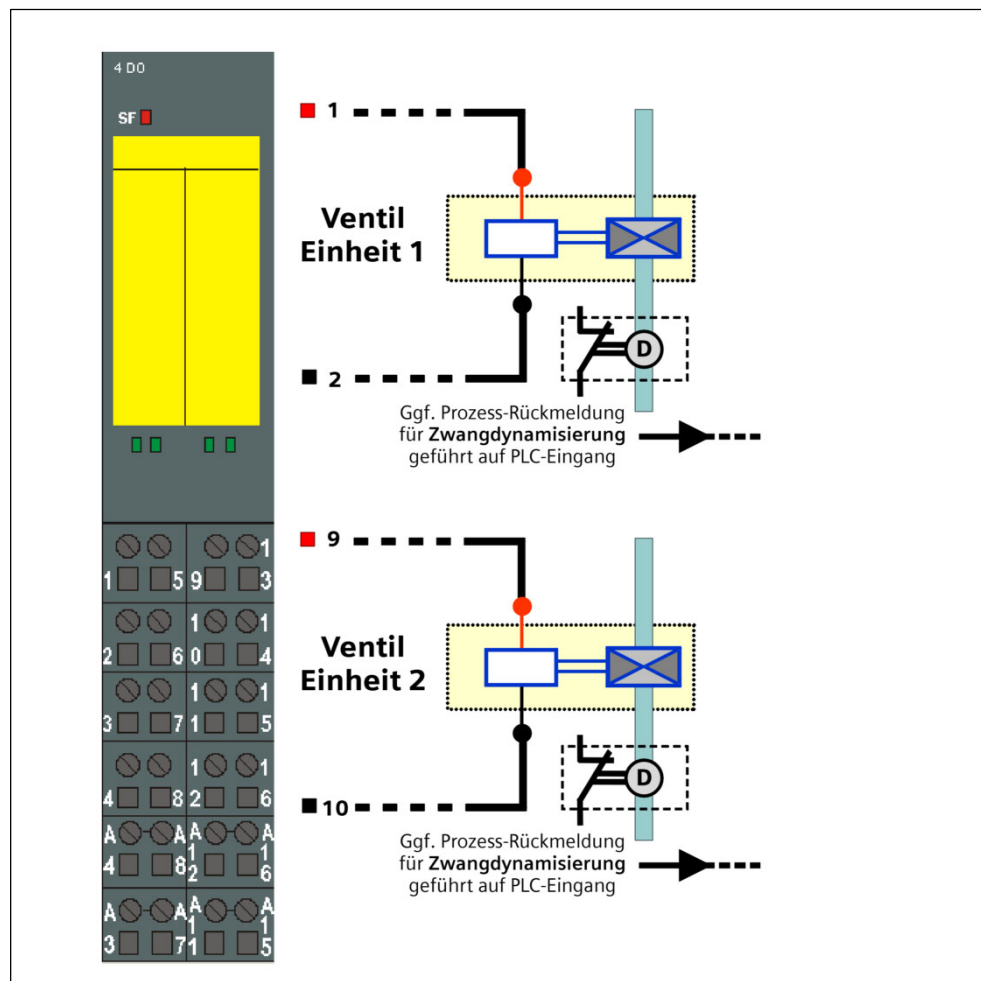

Fig. 10-32 Signal assignment, electronics module, 4F-DO, DC 24 V/2 A, PROFI-safe

Significance and use of the individual signals:

F-DO – terminals 1,2 (channel 0 P/M)

Signal status, channel 0 = "0"

Valve in the blocking-quietest position

Signal status, channel 0 = "1"

Valve open

F-DO terminals 5,6 (channel 1 P/M) – not assigned

F-DO – terminals 9,10 (channel 2 P/M)

Signal status, channel 2 = "0"

Valve in the blocking-quietest position

Signal status, channel 2 = "1"

Valve open

F-DO terminals 13,14 (channel 3 P/M) – not used

Power module PM-E F

This module combines two functions. On the one hand, individual actuators can be connected to all 3 two-channel output channels (this functionality is comparable to the functionality of an F-DO module); on the other hand, the third output channel DO 2 has an additional function.

Output channel DO2 is used to internally switch-out the safety-related (i.e. via two voltage potentials) power supply for the downstream standard DO or standard DI modules. No external wiring is required. This means that the outputs on the DO modules can be controlled as single-channel outputs in the PLC for the "normal" function – after the PM-E F module, all of the DO modules can be shut down in a safety-related fashion.

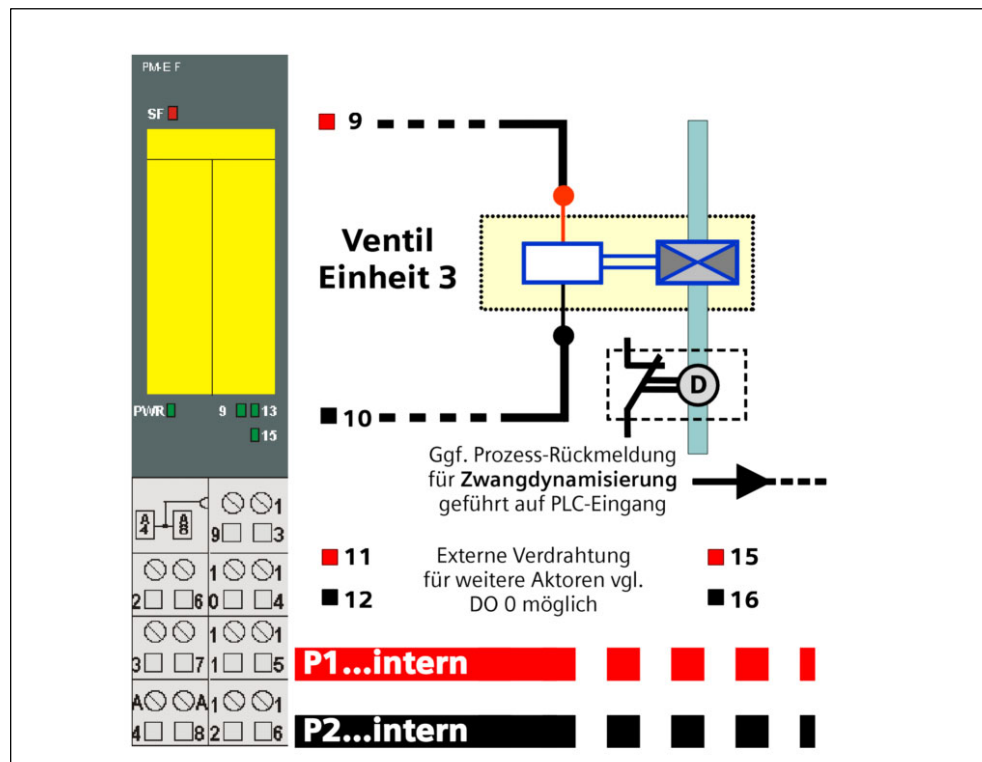

Fig. 10-33 Signal assignment, power module PM-E F PROFIsafe 24 V DC

Significance and use of the individual signals:

PM-E F terminals 9,10 (channel 0 P/M)

Signal status, channel 0 = "0"

Valve in the blocking–quiescent position

Signal status, channel 0 = "1"

Valve open

PM-E F terminals 13,14 (channel 1 PM)

PM-E F terminals 11,12 or 15,16

10.6 Application example with PROFIsafe connection

Externally disconnecting the power supply for the downstream DO module (terminals 11,12 or terminals 15,16)

Signal status, channel 2 = "0"

The power supply for the downstream DO module is disconnected through the two voltage buses P1/P2.

Signal status, channel 2 = "1"

The power supply for the downstream DO module is switched-in through the two voltage buses P1/P2.

Power module PM-D F 24 V DC PROFIsafe

The power module can shutdown – in a safety-related fashion – the voltage buses SG 1 to SG 6 through 6 digital outputs. The outputs are implemented using 2 P switches. There is a main switch for all 6 shutdown groups and 6 subsequent (downstream) individual switches for each shutdown group.

The voltage bus U 1 (electronics power supply for the motor starter) is supplied with 24 V DC. If an overvoltage or undervoltage condition exists, U 1 is shutdown through 2 P switches and the subsequent (downstream) motor starters are brought into the passive state. If the motor starter is safely shutdown, U 1 is not shutdown.

Through the 6 available shutdown groups (SG1...SG6), the power module is, among other things, suitable for supplying fail-safe motor starters such as F-DS1e-x and F-RS1e-x.

Fail-safe direct starters F-DS1e-x

The fail-safe direct starter with electronic overload protection can either power-up or power-down the connected motor (implemented in the application through the PLC I/O interface). Further, when the SG signal is missing at the upstream PM-D F, the PM module can shutdown the motor in a safety-related fashion.

Depending on the type, three-phase motors up to 7.5 kW can be connected and operated – with integrated protection against overload and short-circuit.

The safety shutdown groups SG1...SG6 are assigned to the fail-safe motor starters on one hand through the STEP 7 hardware configuration (refer to Chapter 10.6.7 Engineering and connecting the ET 200S I/O > Components of the device IM151 HF: PM-D F module and F-DSe-x module. On the other hand, the assignment is realized using the coding connector on the terminal module of the motor starter. Both assignments must match one another.

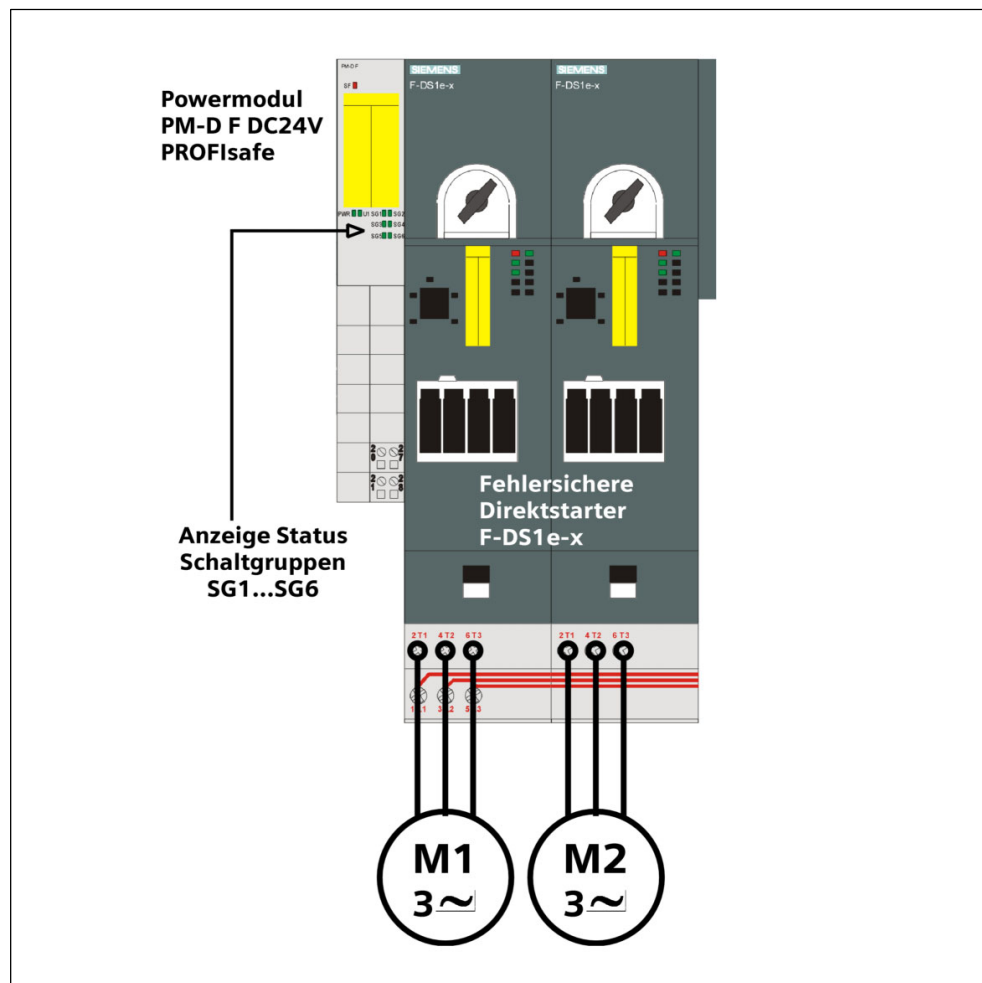

Fig. 10-34 Signal assignment, power module PM-D F 24 V DC PROFIsafe and fail-safe motor starter F-DS1e-x

Significance and use of the individual signals:

(External) wiring is not required. The safety-related shutdown is realized internally using the shutdown groups SG1...SG6.

In addition to the safety-related shutdown using the upstream PM-D F PROFIsafe module, when the shutdown group is enabled, the motor starter can be powered-up and powered-down via its PLC output interface.

The I/O assignment (the I/O addresses must be set ≤ 127) is described in the associated Product Manual "ET 200S fail-safe motor starters" as process image.

Among others, the motor is powered-up or powered-down from the PLC via D0.0 (i.e. the selected PLC output address.0).

10.6 Application example with PROFIsafe connection

10.6.6 Individual functions of the application

The button <drives ON> is only used to acknowledge the internal Emergency Stop state. This button has no function in ongoing operation. The logical interrelationships between the individual, safety-related signals and functions are shown in the subsequent function table. The starting (initial) point of the description is that the Emergency Stop state has been acknowledged.

Table 10-2 Application functions

Sensor	State	Axes, spindles/external units	Monitoring function/switching state
Emergency Stop	Not pressed	Axes/spindles	SG3 (> maximum velocity)
Protective door	Closed and interlocked	Valve unit 1	Open position
Agreement button	Not relevant	Valve unit 2	Open position
		Valve unit 3	Open position
		Motor M1	Powered-up
		Motor M2	Powered-up
Case 1		Supply voltages DO	Powered-up
Emergency Stop	Not pressed	Axes/spindles	SBH
<u>Protective door</u>	Released and/or open	Valve unit 1	Blocking – quiescent position
Agreement button	Not pressed	Valve unit 2	Blocking – quiescent position
		Valve unit 3	Blocking – quiescent position
		Motor M1	Powered-up
		Motor M2	Powered-down
Case 2		Supply voltages DO	Powered-down
Emergency Stop	Not pressed	Axes/spindles	SG1
Protective door	Released and/or open	Valve unit 1	Open position
<u>Agreement button</u>	Pressed	Valve unit 2	Blocking – quiescent position
		Valve unit 3	Open position
		Motor M1	Powered-up
		Motor M2	Powered-down
Case 3		Supply voltages DO	Powered-down
<u>Emergency Stop</u>	Actuated	Axes/spindles	STOP C → SBH
Protective door	Released and/or open	Valve unit 1	Blocking – quiescent position
Agreement button	Pressed	Valve unit 2	Blocking – quiescent position
		Valve unit 3	Blocking – quiescent position
		Motor M1	Powered-down

Table 10-2 Application functions, continued

Sensor	State	Axes, spindles/external units	Monitoring function/switching state
		Motor M2	Powered-down
Case 4		Supply voltages DO	Powered-down
<u>Emergency Stop</u>	Actuated	Axes/spindles	STOP D -> SBH
Protective door	Closed and interlocked	Valve unit 1	Blocking – quiescent position
Agreement button	Pressed	Valve unit 2	Blocking – quiescent position
		Valve unit 3	Blocking – quiescent position
		Motor M1	Powered-up
		Motor M2	Powered-down
Case 5		Supply voltages DO	Powered-down

10.6.7 Configuring and connecting-up the ET 200S I/O

PROFIBUS connection (total system)

Only the part required to connect the ET 200S line-up to Profibus is shown here:

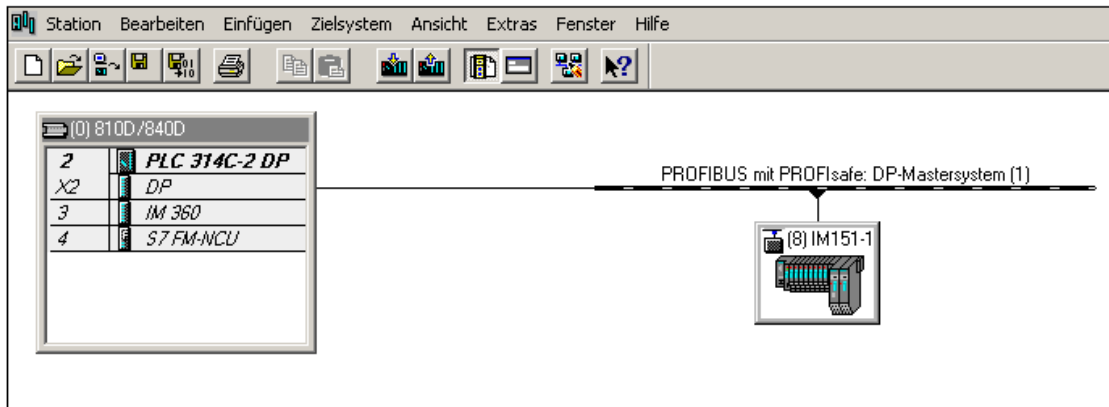

Fig. 10-35 STEP 7 hardware configuration: Definition of the PROFIBUS system

The system requirements regarding the NCU hardware and interface module must be observed (refer to Chapter 5.11 "SI I/Os using fail-safe modules on PROFIBUS-DP> system requirements").

10.6 Application example with PROFI-safe connection

Note

When describing how the F I/Os are configured, the associated parameters are only described to some extent or, only in the form of an overview. More detailed information is provided in the *context-sensitive online help* and in the Manual *ET 200S Distributed I/O System, Fail-Safe Modules*.

PROFIBUS device, IM151 High Feature configuration

The I/O addresses of the PROFI-safe modules should be set outside the OB1 image (values > 128). The fail-safe motor starters do not have any F parameters. These can be powered-up or powered-down (in a non safety-related fashion) using the standard I/O interface. The safety-related handling of motor starters is exclusively realized through the upstream fail-safe power module PM-D F 24 V DC PROFI-safe.

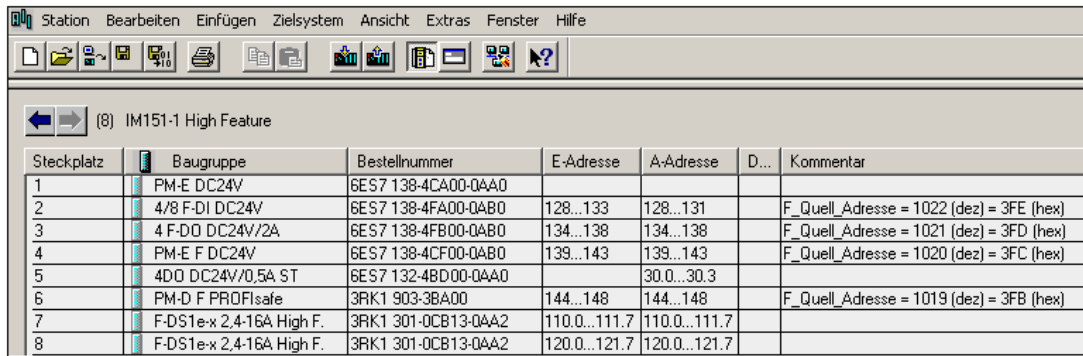

Steckplatz	Baugruppe	Bestellnummer	E-Adresse	A-Adresse	D...	Kommentar
1	PM-E DC24V	6ES7 138-4CA00-0AA0				
2	4/8 F-DI DC24V	6ES7 138-4FA00-0AB0	128...133	128...131		F_Quell_Adresse = 1022 (dez) = 3FE (hex)
3	4 F-DO DC24V/2A	6ES7 138-4FB00-0AB0	134...138	134...138		F_Quell_Adresse = 1021 (dez) = 3FD (hex)
4	PM-E F DC24V	6ES7 138-4CF00-0AB0	139...143	139...143		F_Quell_Adresse = 1020 (dez) = 3FC (hex)
5	4DO DC24V/0,5A ST	6ES7 132-4BD00-0AA0		30.0...30.3		
6	PM-D F PROFI-safe	3RK1 903-3BA00	144...148	144...148		F_Quell_Adresse = 1019 (dez) = 3FB (hex)
7	F-DS1e-x 2,4-16A High F.	3RK1 301-0CB13-0AA2	110.0...111.7	110.0...111.7		
8	F-DS1e-x 2,4-16A High F.	3RK1 301-0CB13-0AA2	120.0...121.7	120.0...121.7		

Fig. 10-36 STEP 7 hardware configuration: Equipping, IM151-1 High Feature

Components of the device IM151 HF: F–DI module

The parameter settings for the F–DI module relevant for the safety–related function are shown in the following diagram:

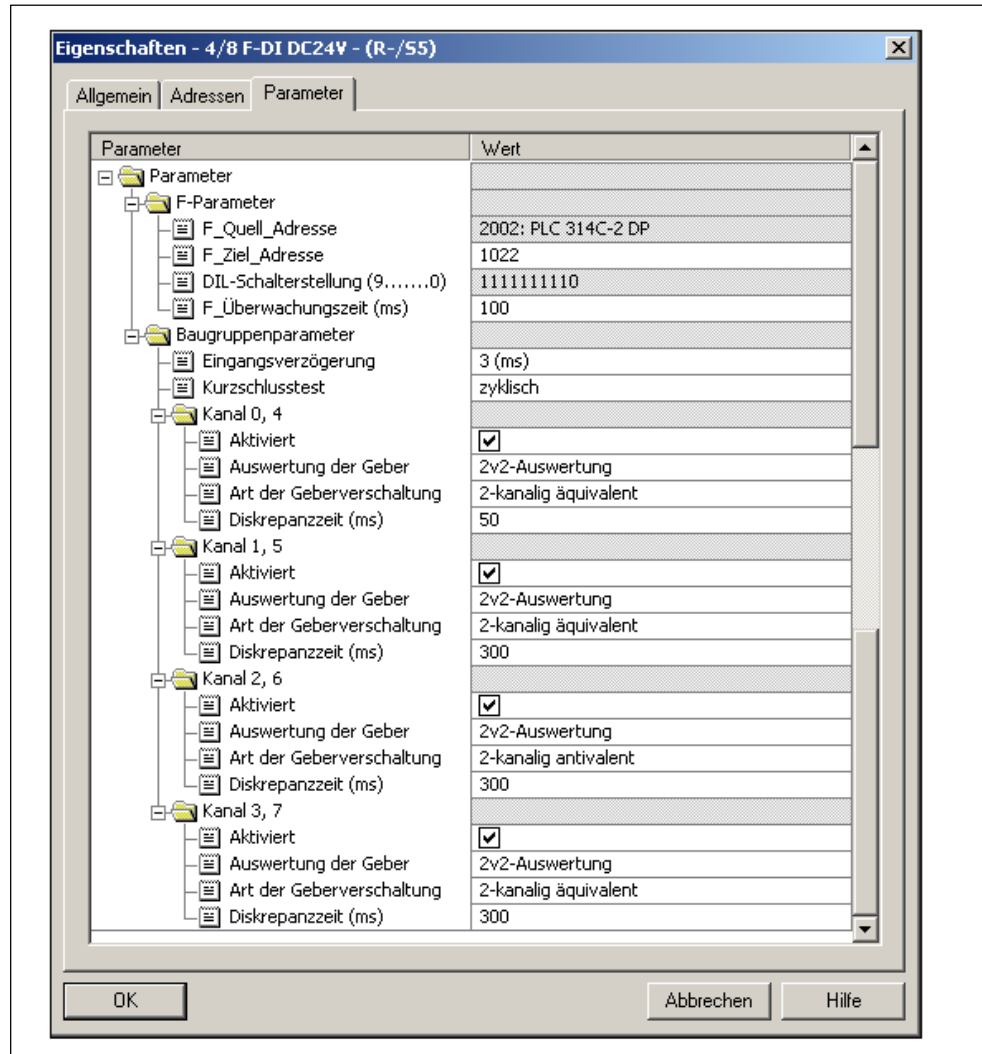

Fig. 10-37 Parameter setting, F–DI module

Explanation of the parameters

The parameters of the F–DI module are explained below:

- **F_source_address**

The parameter F_source_address is automatically assigned for the configured F master (in this case, the NCU 57x.4). This parameter is the same for all PROFIsafe components as they all belong to the same PROFIsafe master. Principle for allocating the F_source_address (= PROFIsafe master address) = PROFIBUS address of the PROFIBUS master + 2000 (the offset can be set).

10.6 Application example with PROFI-safe connection

- **F_target_address**

The parameter F_target_address is automatically assigned for the particular F module and is displayed in the decimal format (1022 for the F-DI module). The parameter can be subsequently adapted (from F Configuration Pack V5.3 SP1 onwards). The DIL switch setting shown should be set at the module according to this specification. This address will be subsequently used to parameterize machine data in the hexadecimal format (for the 3FE F-DI module).
- **F_monitoring time**

The parameter F_monitoring time defines the maximum time within which a new valid F telegram must have been received from the F master. Generally, the default value can be used.
- **Input delay**

In order to suppress coupled-in noise and disturbances, using the input delay parameter (in ms) it is possible to define a noise/disturbance pulse length. Fault pulses of 0 ms up to the selected value are then suppressed.
- **Short-circuit test**

The short-circuit test parameter activates the short-circuit detection for the module. However, the test only makes sense if simple switches are used that are connected through the two encoder power supplies (VS1, VS2) inside the module. It should be taken into consideration that every input terminal is assigned to test a supply voltage (refer to Chapter 10.6.3, connecting-up the sensors and actuators → electronics module 4/8 F-DI DC 24 V PROFI-safe).
- **Encoder evaluation**

In the example, all of the input sensors are connected-up through two channels (refer to the Fig. 10-31 Signal assignment, electronics module, 4/8F-DI, DC 24 V, PROFI-safe). This is the reason that the encoder evaluation with 2v2 evaluation type is set for all 4 channel pairs.
- **Type of encoder connection**

The type of encoder connection depends on the encoder design. For NC and NO contact pairs (channels 0,4; channels 1,5; channels 3,7) the 2-channel equivalence version should be set; on the other hand, for the agreement button in the exclusive OR configuration (one NC and one NO contact), the exclusive OR 2-channel version should be used.
- **Discrepancy time**

The discrepancy time parameter is used to enter the monitoring time for the discrepancy analysis (this is only relevant for 2v2 evaluation). If there is still a signal difference between two associated input signals after the discrepancy time has expired, this is detected as an error in the module and signaled to the master. The length of this time should be aligned to the switching duty cycle (both channels) for the connected sensor.
Only one signal state is transferred to the master via the PROFI-safe protocol. This means that a crosswise comparison error in the control system, referred to two different input signal states can no longer occur. The discrepancy analysis is executed in a distributed fashion – this means that the time should be set corresponding to the connected sensor.

Components of the device IM151 HF: F–DO module

The next diagram shows the parameter settings for the F–DO module relevant for the safety–related function:

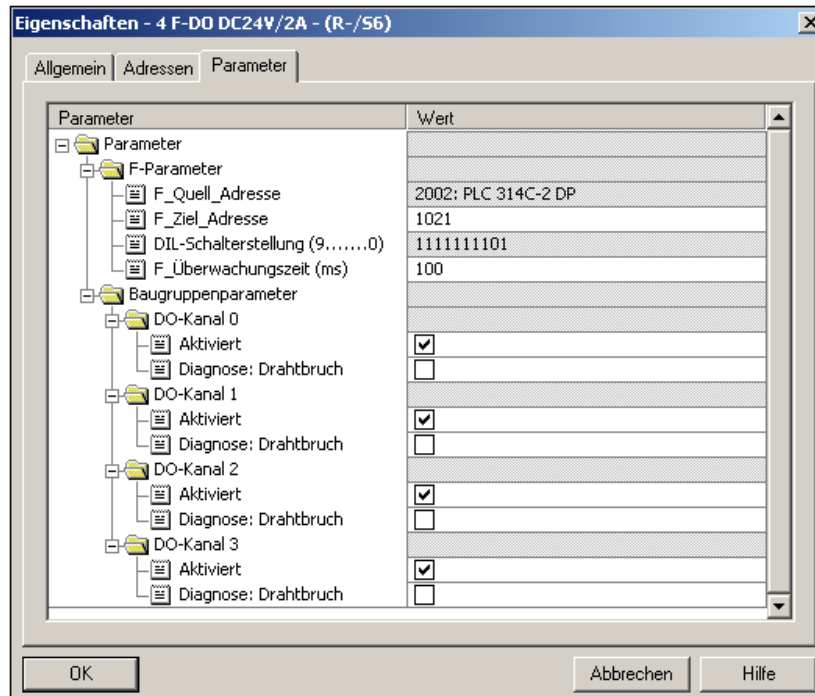

Fig. 10-38 Parameter settings, FDO module

Explanation of the parameters

The parameters of the F–DO module are explained below:

- F parameters**
 The F parameters have already been explained in conjunction with the F–DI module (refer above). The target address for the F–DO module is, in the hexadecimal format, 3FD.
- DO channels**
 The individual DO channels can be separately activated and de–activated.
- Diagnostics: Wire breakage**
 Further, using diagnostics: Wire breakage, it is possible to set as to whether the connection from the output to the actuator for the particular channel is to be checked for wire breakage – and then signaled to the master.

Components of the device IM151 HF: PM–E F module

The following diagram shows the parameter settings for the PM–E F module relevant for the safety–related function:

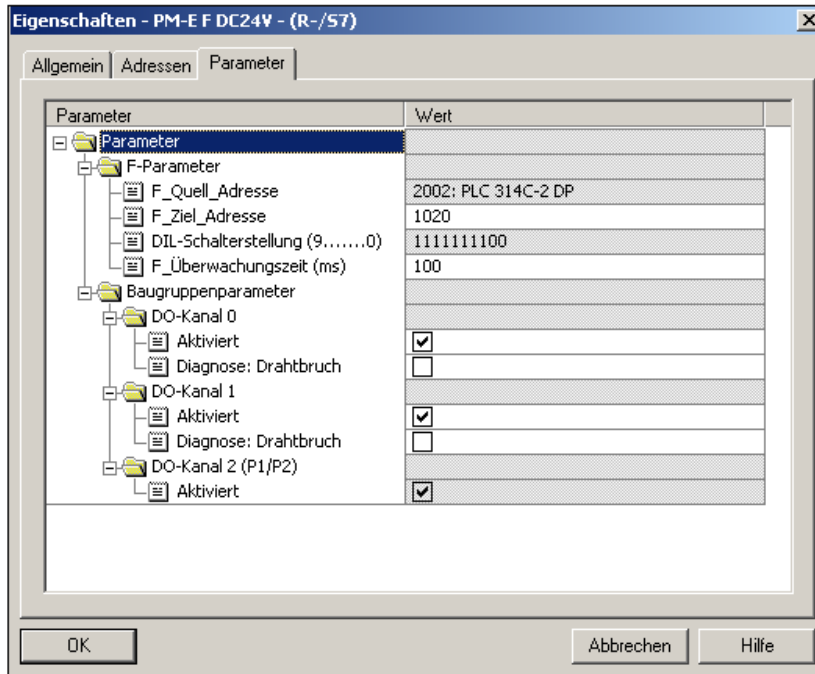

Fig. 10-39 Parameter settings, PM–E F module

Explanation of the parameters

The parameters of the PM–D F module are explained below:

- F parameters**
 The F parameters have already been explained in conjunction with the F–DI module (refer above). The target address for the PM–D F module in the hexadecimal format is 3FC.
- DO channels 0/1**
 The parameterization of the individual DO channels has already been explained in conjunction with the F–DO.
- DO channel 2 (P1/P2)**
 The third output pair (DO channel 2 (P1/P2)) cannot be de–activated. This channel is used to internally switch–in or switch–out the safety–related power supply for the subsequent (downstream) standard DO or also standard DI modules (refer to Fig. 10-33, Signal assignment, power module PM–E F PROFIsafe DC 24 V).
- Additional parameters**
 cannot be set at the PM–D F module.

Components of the device IM151 HF: PM-D F module

The following diagram shows the parameter settings for the PM-D F module relevant for the safety-related function:

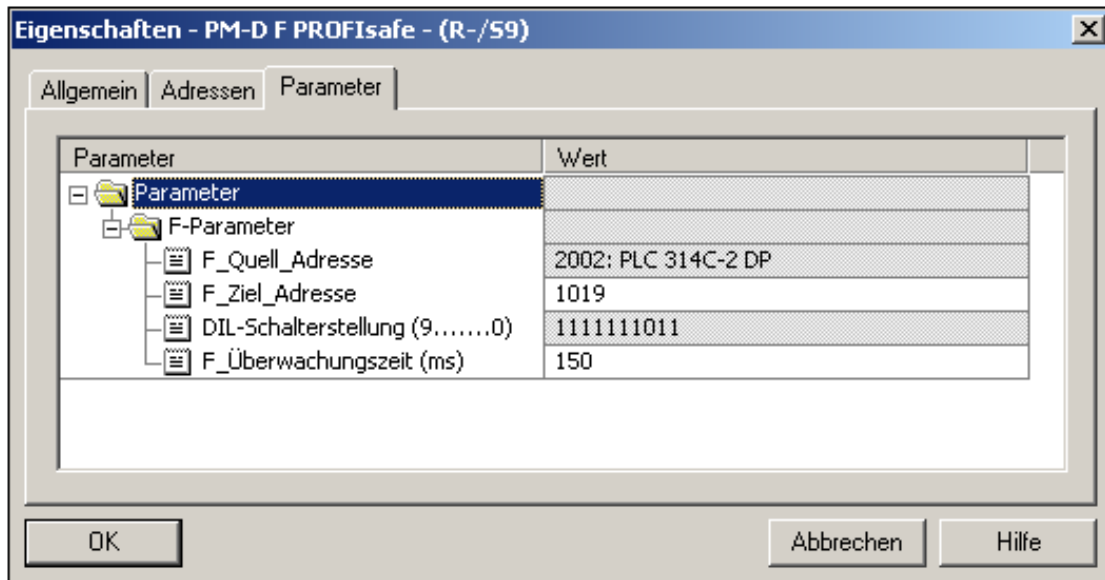

Fig. 10-40 Parameter settings, PM-D F module

Explanation of the parameters

The parameters of the PM-D F module are explained below:

- F parameters**
 The F parameters have already been explained in conjunction with the F-DI module (refer above). The target address for the PM-D F module in the hexadecimal format is 3FB. The standard value for the F monitoring time is pre-set at 150 ms for the PM-D F module.
- Additional parameters**
 cannot be set at the PM-D F module.

Components of the device IM151 HF: F-DS1e-x module (M1)

The following diagram shows the parameter settings for the F-DS1e-x module (motor starter for motor M1) relevant for the safety-related function

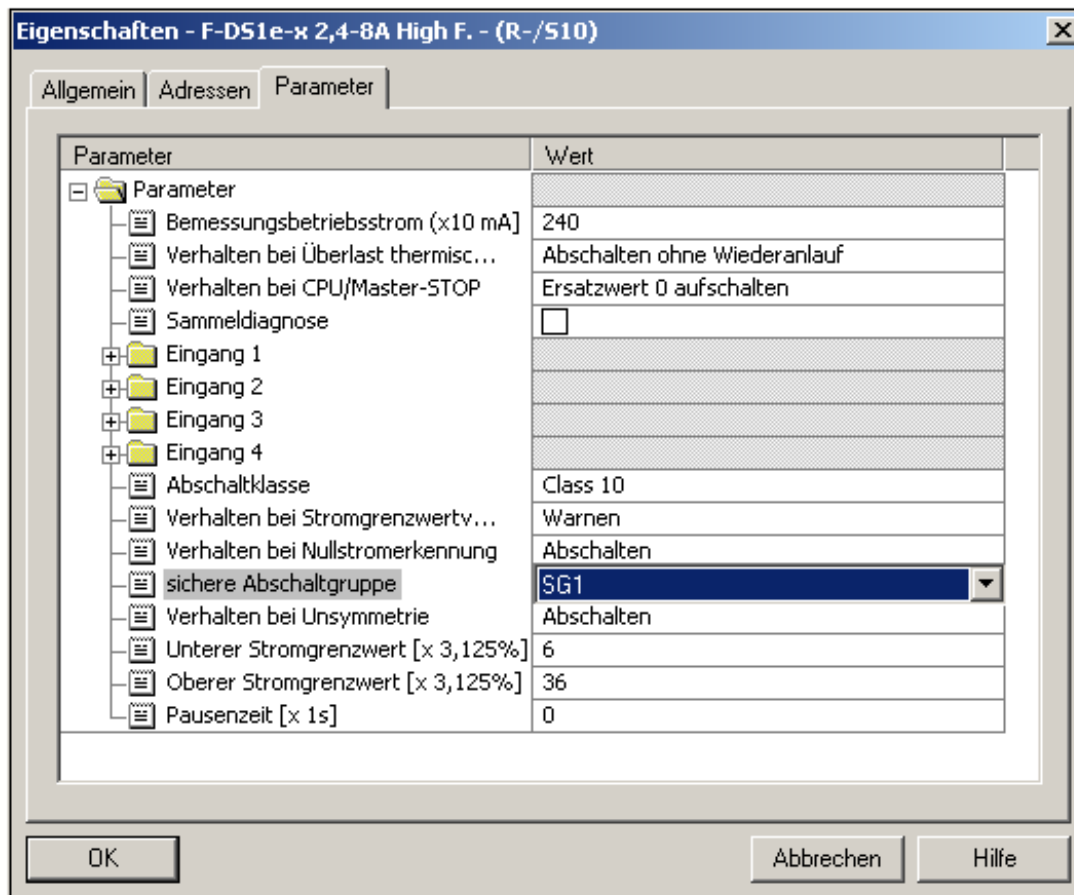

Fig. 10-41 Parameter settings, F-DS1-e-x module (M1)

Below is an explanation of the parameters of the F-DS1e-x module:

- **F parameters**
None
- **Safety-related parameter, "safety shutdown group"**
Using this parameter, the safety shutdown group of the upstream PM-D-F module is assigned via which the motor starter can be shutdown in a safety-related fashion. This setting must match the HW (hardware) setting at the coding connector on the associated terminal module.
Motor starter 1 is assigned shutdown group SG1

Components of the device IM151 HF: F-DS1e-x module (M2)

The following diagram shows the parameter settings (excerpt) for the F-DS1e-x module (motor starter for motor M2) relevant for the safety-related function

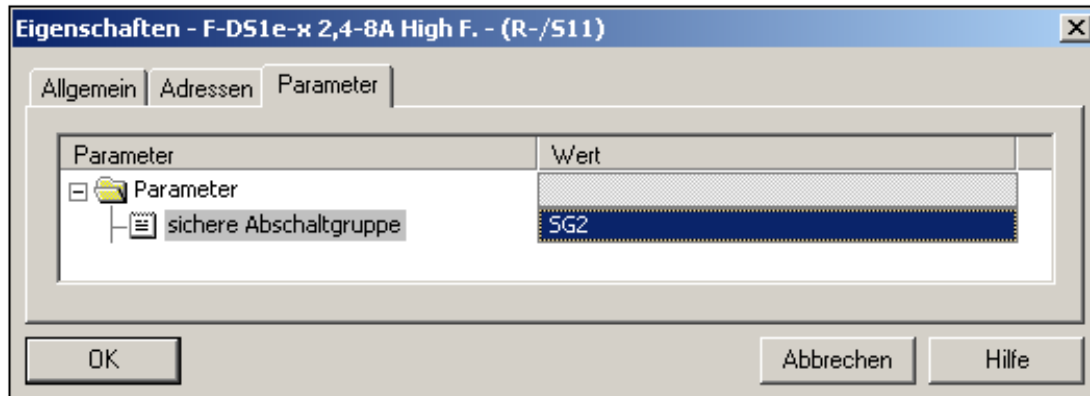

Fig. 10-42 Parameter settings, F-DS1-e-x module (M2)

Below is an explanation of the parameters of the F-DS1-e-x module:

- **F parameters**
None
- **Safety-related parameter, "safety shutdown group"**
Using this parameter, the safety shutdown group of the upstream PM-D-F module is assigned via which the motor starter can be shutdown in a safety-related fashion. This setting must match the HW (hardware) setting at the coding connector on the associated terminal module.
Motor starter 1 is assigned shutdown group SG2

10.6.8 Parameterization Sinumerik 840D NCK

Parameterizing PROFIsafe – general information

Addressing the PROFIsafe master (refer to the parameter F_source address)
2002 (dec) corresponds to 7D2 (hex)

- MD 10385 \$MN_PROFISAFE_MASTER_ADDRESS = **05 00 07 D2_H**

Setting the PROFIsafe clock cycle

- MD 10071 \$MN_IPO_CYCLE_TIME = 0.006 s
- MD 10098 \$MN_PROFISAFE_IPO_TIME_RATIO = **3** (=> 0.018 s)

When setting the PROFIsafe clock cycle, refer to:

Chapter 3, SI I/O using fail-safe modules connected to PROFIBUS-DP
Configuring and parameterizing the ET 200S F I/O
PROFIsafe clock cycle and DP cycle time

10.6 Application example with PROFIsafe connection

Connecting SPL hardware inputs (\$A_INSE(P)/\$A_OUTSE(P) signals)

Mapping inputs from the F–DI module to \$A_INSE(P) variables 1..4

- MD 10386 \$MN_PROFISAFE_IN_ADDRESS[0] = **05 00 03 FE_H**
- MD 10388 \$MN_PROFISAFE_IN_ASSIGN[0] = **004 001**

In the case of an agreement button connected–up in an exclusive OR configuration, when OK, the signal state is transferred to the SPL defined by the lower channel (in the example, channel 2).

\$A_OUTSE(P) variables 1..4 are output on the F–DO module

- MD 10387 \$MN_PROFISAFE_OUT_ADDRESS[0] = **05 00 03 FD_H**
- MD 10389 \$MN_PROFISAFE_OUT_ASSIGN[0] = **004 001**

\$A_OUTSE(P) variables 5..7 are output on the PM–E F module

- MD 10387 \$MN_PROFISAFE_OUT_ADDRESS[1] = **05 00 03 FC_H**
- MD 10389 \$MN_PROFISAFE_OUT_ASSIGN[1] = **007 005**

\$A_OUTSE(P) variables 8..13 are output on the PM–D F module (SG1 ...SG6)

- MD 10387 \$MN_PROFISAFE_OUT_ADDRESS[2] = **05 00 03 FB_H**
- MD 10389 \$MN_PROFISAFE_OUT_ASSIGN[2] = **013 008**

SGE input signals, supplying the SGE interface using \$A_OUTSI(P) variables

A few definitions are now required in order to be able to explain safe programmable logic (SPL). This is the reason that not all of the parameterized machine data for Safety Integrated will be described. Furthermore, axial machine data are only specified to represent an axis.

De–selecting SBH using \$A_OUTSI[1]

- MD 36970 \$MA_SAFE_SS_DISABLE_INPUT = **04 01 01 01_H**

Selecting SG, bit 1 using \$A_OUTSI[2]

- MD 36972 \$MA_SAFE_VELO_SELECT_INPUT[0] = **04 01 01 02_H**

De–selecting STOP A using \$A_OUTSI[3]

- MD 36977 \$MA_SAFE_EXT_STOP_INPUT[0] = **04 01 01 03_H**

De–selecting STOP C using \$A_OUTSI[4]

- MD 36977 \$MA_SAFE_EXT_STOP_INPUT[1] = **04 01 01 04_H**

De–selecting STOP D using \$A_OUTSI[5]

- MD 36977 \$MA_SAFE_EXT_STOP_INPUT[2] = **04 01 01 05_H**

These safety–related internal input signals are used to implement the functions described above.

10.6.9 Programming the NCK–SPL

The complete SPL logic is not shown, only the parts required to understand the application. The parts not shown include controlling terminal 663 and the forced checking procedure.

```

; +-----+
; |           Safe Programmable Logic (NCK-SPL) |
; +-----+
; File:      SAFE.SPF
;           Excerpt to explain PROFIsafe
; last change: 06.04.2004 15:35
;
; -----
; D e s c r i p t i o n :
; - NCK-SPL
; - logically combining/linking the input variables of the SPL
; External (from PROFIsafe)   : $_INSE (MD 10386 10388)
; Internal (from SI kernel)   : $_INSI (MD 36980..36990)
; To output variables of the SPL
; Internal (on the SI kernel) : $_OUTSI (MD 36970..36978)
; External (on PROFIsafe)     : $_INSE (MD 10387 10389)
; E n d   D e s c r i p t i o n
; -----
;
; ----- Cycle definition -----
;           Suppress single block, display
; -----
N100 PROC SAFE SBLOF DISPLOF
; -----
N102 DEF INT STAT_IN, STAT_OUT, STAT_TIME
; ----- Variable declarations -----
;           Definition of symbolic names for SPL variables
; -----
;           Addressing PROFIsafe input modules
; MD 10386 $MN_PROFISAFE_IN_ADDRESS[n]
;           Assigning PROFIsafe signals to SPL
; MD 10388 $MN_PROFISAFE_IN_ASSIGN[n]
; -----
;MD 10386[0]/MD 10388[0] : F-DI      NCK          ; PLC-DB18.
; -----
N105 DEFINE IE01_NOHALT           AS $_INSE[01]      ; DBX38.0
N110 DEFINE IE02_SCHUTZTUER_OK    AS $_INSE[02]      ; DBX38.1
N115 DEFINE IE03_ZUSTIMMUNG       AS $_INSE[03]      ; DBX38.2
N120 DEFINE IE04_ANTRIEBE_EIN     AS $_INSE[04]      ; DBX38.3
;=====
;internal inputs (mapping/emulating SGA 36980..36990); PLC-DB18.
;-----
;not used for the example
N105 DEFINE II01_reserve          AS $_INSI[01]      ; DBX55.0
;=====

```

10.6 Application example with PROFIsafe connection

```

;internal outputs (assigned to SGE 36970..36978); PLC-DB18.
;-----
N425 DEFINE OI01_SBH_ABWAHL      AS $A_OUTSI[01] ; DBX62.0
N430 DEFINE OI02_SG_AUSW_B1     AS $A_OUTSI[02] ; DBX62.1
N435 DEFINE OI03_STOPA_ABW      AS $A_OUTSI[03] ; DBX62.2
N440 DEFINE OI04_STOPC_ABW      AS $A_OUTSI[04] ; DBX62.3
N445 DEFINE OI05_STOPD_ABW      AS $A_OUTSI[05] ; DBX62.4
;=====
; Addressing PROFIsafe input modules
; MD 10387 $MN_PROFISAFE_OUT_ADDRESS[n]
; Assigning PROFIsafe signals to SPL
; MD 10389 $MN_PROFISAFE_OUT_ASSIGN[n]
;-----
;MD 10387[0]/MD 10389[0] : F-DO NCK ; PLC-DB18.
;-----
N585 DEFINE OE01_VENTIL1        AS $A_OUTSE[01] ; DBX46.0
N590 DEFINE OE02_Reserve        AS $A_OUTSE[02] ; DBX46.1
N595 DEFINE OE03_VENTIL2        AS $A_OUTSE[03] ; DBX46.2
N600 DEFINE OE04_Reserve        AS $A_OUTSE[04] ; DBX46.3
;MD 10387[1]/MD 10389[1] : PM-EF NCK ; PLC-DB18.
;-----
N605 DEFINE OE05_VENTIL3        AS $A_OUTSE[05] ; DBX46.4
N610 DEFINE OE06_Reserve        AS $A_OUTSE[06] ; DBX46.5
N615 DEFINE OE03_P1P2           AS $A_OUTSE[07] ; DBX46.6
;MD 10387[2]/MD 10389[2] : PM-DF NCK ; PLC-DB18.
;-----
N620 DEFINE OE08_SG_1           AS $A_OUTSE[08] ; DBX46.7
N625 DEFINE OE09_SG_2           AS $A_OUTSE[09] ; DBX47.0
N630 DEFINE OE010_SG_3          AS $A_OUTSE[10] ; DBX47.1
N620 DEFINE OE011_SG_1          AS $A_OUTSE[11] ; DBX47.2
N625 DEFINE OE012_SG_2          AS $A_OUTSE[12] ; DBX47.3
N630 DEFINE OE013_SG_3          AS $A_OUTSE[13] ; DBX47.4
;=====
;MARKERSI : Internal state markers ; PLC-DB18.
;-----
N665 DEFINE MI01_NOHALT_OK      AS $A_MARKERSI[01] ; DBX70.0
N670 DEFINE MI02_ZUSTIMMUNG     AS $A_MARKERSI[02] ; DBX70.1
N675 DEFINE MI03_AUX_NH_Quit    AS $A_MARKERSI[03] ; DBX70.2
N680 DEFINE MI04_STOPA_ABW      AS $A_MARKERSI[04] ; DBX70.3
;=====
;TIMERSI : Internal timers ; PLC timers
;-----
N700 DEFINE TI01_Reserve        AS $A_TIMERSI[01] ; T xxxx not used
for the example
;=====
;PLCSIOUT : Single-channel data from the PLC -> NCK ; PLC-DB18.
;-----
N800 DEFINE IP01_TEST_A         AS $A_PLCSIOUT[01] ; DBX128.0
N805 DEFINE IP02_TEST_C         AS $A_PLCSIOUT[02] ; DBX128.1
N810 DEFINE IP03_TEST_D         AS $A_PLCSIOUT[03] ; DBX128.2
;=====
;PLCSIIN : Single-channel data from the NCK -> PLC ; PLC-DB18.
;-----

```

10.6 Application example with PROFIsafe connection

```

N820 DEFINE OP01_Reserve      AS $A_PLCSIIN[01] ; DBX132.0 not used
for the example
;=====
;=====
; variable definition for SIRELAY
;-----
N825 DEFINE STAT_SIR1 AS $AC_MARKER[1]
;=====
; initialization for SIRELAY
;-----
; inputs
; regular acknowledge via :                IE04_ANTRIEBE_EIN
; temporary acknowledge - possibly for test: MI03_AUX_NH_QUIT
; signal input for Emergency Stop circuit 1 : IE01_NOTHALT
; signal input for Emergency Stop circuit 2/3 : not used
N830 SIRELIN (1,STAT_IN,"IE04_ANTRIEBE_EIN","MI03_AUX_NH_QUIT",
"IE01_NOTHALT")
; outputs
; signal output, instantaneous shutdown :    MI01_NOTHALT_OK
; signal output, delayed shutdown 1 :       MI04_STOPA_ABW
; signal output, delayed shutdown 2/3 :     not used
N835 SIRELOUT (1,STAT_OUT,"MI01_NOTHALT_OK","MI04_STOPA_ABW")
; times
; time window for temporary acknowledge:    0.5s
; time window for delayed shutdown 1 :      1.5s
; time window for delayed shutdown 2/3 :    not used
N840 SIRELTIME(1,STAT_TIME,0.5,1.5)
;
; ----- Program part -----
; INSE/INSI ---> OUTSI/OUTSE (memory MARKERSI)
; -----
;
; ----- SPL protection -----
; first static synchronous action: IDS = 01 (MD 11500[0])
; last static synchronous action: IDS = 23 (MD 11500[1])
;
; Emergency Stop via SIRELAY(1 from 4)
N900 IDS=01 DO STAT_SIR1 = SIRELAY(1)
; de-select external Stop A
N905 IDS=03 DO OI03_STOPA_ABW = MI04_STOPA_ABW AND NOT IP01_TEST_A
de-select external Stop C
N910 IDS=05 DO OI04_STOPC_ABW = (MI01_NOTHALT_OK OR IE02_SCHUTZ-
TUER_OK) AND NOT IP02_TEST_C de-select external Stop D
N915 IDS=07 DO OI05_STOPD_ABW = (MI01_NOTHALT_OK OR NO-
TIE02_SCHUTZTUER_OK) AND NOT IP03_TEST_D agreement mode
N920 IDS=09 DO MI02_ZUSTIMMUNG = NOT IE02_SCHUTZTUER_OK AND
IE03_ZUSTIMMUNG SBH de-selection (when the protective door is closed
or in the agreement mode)
N925 IDS=11 DO OI01_SBH_ABWAHL = IE02_SCHUTZTUER_OK OR MI02_ZUSTIM-
MUNG SG changeover (select SG3 when the protective door is closed)
N930 IDS=13 DO OI02_SG_AUSW_B1 = IE02_SCHUTZTUER_OK valve unit 1
N935 IDS=15 DO OE01_VENTIL1 = MI01_NOTHALT_OK AND OI01_SBH_AB-
WAHL valve unit 2

```

10.6 Application example with PROFIsafe connection

```

N940 IDS=17 DO OE03_VENTIL2 =      MI01_NOTHALT_OK AND IE02_SCHUTZ-
TUER_OK valve unit 3
N945 IDS=19 DO OE05_VENTIL3 =      OE01_VENTIL1 supply voltages DO
N950 IDS=21 DO OE07_P1P2 =          OE03_VENTIL2 switching group 1
(SG1) for motor starter 1
N955 IDS=23 DO OE08_SG_1 =          MI01_NOTHALT_OK switching group 2
(SG2) for motor starter 2
N960 IDS=23 DO OE09_SG_2 =          MI01_NOTHALT_OK AND IE02_SCHUTZ-
TUER_OK
N970 MSG ("SPL OK")
N980 M30

```

10.6.10 Programming the PLC–SPL

Excerpt from the definition of symbols, DB18 "SPL"

Only data areas are listed for which a symbol has been defined for the example.

Table 10-3 Excerpt, symbol definition DB18 "SPL"

Address	Name	Type	Initial value	Comment
...
+38.0	IEP01_NOT_HALT	BOOL	FALSE	\$_A_INSEP [1]
+38.1	IEP02_SCHUTZTUER_OK	BOOL	FALSE	\$_A_INSEP [2]
+38.2	IEP03_ZUSTIMMUNG	BOOL	FALSE	\$_A_INSEP [3]
+38.3	IEP04_ANTRIEBE_EIN	BOOL	FALSE	\$_A_INSEP [4]
...
+46.0	OEP01_VENTIL1	BOOL	FALSE	\$_A_OUTSEP [01]
+46.1	OEP02_Reserve	BOOL	FALSE	\$_A_OUTSEP [02]
+46.2	OEP03_VENTIL2	BOOL	FALSE	\$_A_OUTSEP [03]
+46.3	OEP04_Reserve	BOOL	FALSE	\$_A_OUTSEP [04]
+46.4	OEP05_VENTIL3	BOOL	FALSE	\$_A_OUTSEP [05]
+46.5	OEP06_Reserve	BOOL	FALSE	\$_A_OUTSEP [06]
+46.6	OEP07_P1P2	BOOL	FALSE	\$_A_OUTSEP [07]
+46.7	OEP08_SG1	BOOL	FALSE	\$_A_OUTSEP [08]
+47.0	OEP09_SG2	BOOL	FALSE	\$_A_OUTSEP [09]
+47.1	OEP10_SG3	BOOL	FALSE	\$_A_OUTSEP [10]
+47.2	OEP11_SG4	BOOL	FALSE	\$_A_OUTSEP [11]
+47.3	OEP12_SG5	BOOL	FALSE	\$_A_OUTSEP [12]
+47.4	OEP13_SG6	BOOL	FALSE	\$_A_OUTSEP [13]

Table 10-3 Excerpt, symbol definition DB18 "SPL", continued

Address	Name	Type	Initial value	Comment
...
+62.0	OIP01_SBH_ABWAHL	BOOL	FALSE	\$_A_OUTSIP[01]
+62.1	OIP02_SG_AUSW_B1	BOOL	FALSE	\$_A_OUTSIP[02]
+62.2	OIP03_STOPA_ABW	BOOL	FALSE	\$_A_OUTSIP[03]
+62.3	OIP04_STOPC_ABW	BOOL	FALSE	\$_A_OUTSIP[04]
+62.4	OIP05_STOPD_ABW	BOOL	FALSE	\$_A_OUTSIP[05]
...
+70.0	MIP01_KEIN_NOT_HALT	BOOL	FALSE	\$_A_MARKERSIP[01]
+70.1	MIP02_ZUSTIMMUNG	BOOL	FALSE	\$_A_MARKERSIP[02]
+70.2	MIP03_AUX_NH_QUIT	BOOL	FALSE	\$_A_MARKERSIP[03]
+70.3	MIP04_STOPA_ABW	BOOL	FALSE	\$_A_MARKERSIP[04]

PLC-SPL

```

FUNCTION "SPL_FC_PLC" : VOID
TITLE =SPL logic on the PLC side
//PLC-SPL
AUTHOR : MGehr
FAMILY : SPL
VERSION : 3.1

```

```

BEGIN
NETWORK

```

```

TITLE =map external inputs to $_A_INSEP variables
// This step is no longer required for PROFIsafe inputs in the user program.
// The input signals from the F-DI module are also transferred via the param-
// eters of the NCK machine data MD 10386[n] and MD 10388[n] to the correspond-
// ing bits in DB 18. This means that the associated $_A_INSEP variables
// (DB18.DBX38.0 .. DBX 45.7) are written within the system

```

```

NETWORK

```

```

TITLE =map status signals from SI (SGA) -> to internal inputs
// Refer to MD 36980..MD36990
// SGA signals in the axis DB : DBX108.0      DBX111.7
// $_A_INSIP[01] $_A_INSIP[64] : DB18.DBX54.0 ... DB18.DBX61.7
// No $_A_INSIP variables are used for the application example

```

```

NETWORK

```

```

TITLE =SPL logic INSEP/INSIP -> map OUTSIP

```

10.6 Application example with PROFIsafe connection

```

// Refer to SAFE.SPF
// $A_MARKERSIP[1] $A_MARKERSIP[64] : DB18.DBX70.0 DB18.DBX77.7
// $A_OUTSIP[1] $A_OUTSIP[64] : DB18.DBX62.0 DB18.DBX69.7
//
// [IDS=01] Emergency Stop via SIRELAY(1 from 4)
CALL "SI_RELAY" , "DB80_IDB_SI_RELAY" (
  In1 := "SPL".IEP01_NOTHALT, // Input, Emergency Stop circuit
  Quit1 := "SPL".IEP04_ANTRIEBE_EIN, // Acknowledge, regular
  Quit2 := "SPL".MIP03_AUX_NH_QUIT, // Temp. acknowl. for test purposes
  TimeValue1 := T#1S500MS,
  Out0 := "SPL".MIP01_NOTHALT_OK, // Instantaneous
  Out1 := "SPL".MIP04_STOPA_ABW, // Delayed with TimeValue1
  FirstRun := // Signal 1x in OB100 to "1"
  "M100.0_SET_1x_IN_OB100");

// [IDS=03] STOP A - de-select
U "SPL".MIP04_STOPA_ABW;
UN "M100.1_TEST_A_PLC"; // for forced checking proced., ext.
// Stop A = "SPL".OIP03_STOPA_ABW;

// [IDS=05] STOP C - de-select
U( ;
O "SPL".IEP02_SCHUTZTUER_OK;
) ;
UN "M100.2_TEST_C_PLC"; // for forced checking proced., ext.
// Stop C = "SPL".OIP04_STOPC_ABW;

// [IDS=07] STOP D - de-select
U( ;
O "SPL".MIP01_NOTHALT_OK;
ON "SPL".IEP02_SCHUTZTUER_OK;
) ;
UN "M100.3_TEST_D_PLC"; // for forced checking proced., ext.
// Stop D = "SPL".OIP05_STOPD_ABW;

// [IDS=09] agreement mode
UN "SPL".IEP02_SCHUTZTUER_OK;
U "SPL".IEP03_ZUSTIMMUNG;
= "SPL".MIP02_ZUSTIMMUNG;

// [IDS=11] SBH de-select
// (for closed and interlocked protective door OR for the agreement mode)
U "SPL".IEP02_SCHUTZTUER_OK;
O "SPL".MIP02_ZUSTIMMUNG;
= "SPL".OIP01_SBH_ABWAHL;

// [IDS=13] SG changeover
// (select SG3 when the protective door is closed and interlocked)

```

10.6 Application example with PROFIsafe connection

```

U "SPL".IEP02_SCHUTZTUER_OK;
= "SPL".OIP02_SG_AUSW_B1;

NETWORK
TITLE = SPL logic INSEP/INSIP -> map OUTSEP
// Refer to SAFE.SPS
// $A_MARKERSIP[1]...$A_MARKERSIP[64] : DB18.DBX70.0 DB18.DBX77.7
// $A_OUTSIP[1].....$A_OUTSIP[64] : DB18.DBX62.0 DB18.DBX69.7
//
//
// [IDS=15] valve unit 1
U "SPL".MIP01_NOTHALT_OK;
U( ;
U "SPL".IEP02_SCHUTZTUER_OK;
O "SPL".MIP02_ZUSTIMMUNG;
) ;
= "SPL".OEP01_VENTIL1;

// [IDS=17] valve unit 2
U "SPL".MIP01_NOTHALT_OK;
U "SPL".IEP02_SCHUTZTUER_OK;
= "SPL".OEP03_VENTIL2;

// [IDS=19] valve unit 3
U "SPL".OEP01_VENTIL1;
= "SPL".OEP05_VENTIL3;

// [IDS=21] supply voltages DO
U "SPL".OEP03_VENTIL2;
= "SPL".OEP07_P1P2;

// [IDS=23] switching group 1 (SG1) for motor starter 1
U "SPL".MIP01_NOTHALT_OK;
= "SPL".OEP08_SG_1;

// [IDS=25] switching group 2 (SG2) for motor starter 2
U "SPL".MIP01_NOTHALT_OK;
U "SPL".IEP02_SCHUTZTUER_OK;
= "SPL".OEP09_SG_2;

TITLE =assign internal outputs (OUTSIP) to SI inputs (SGE)
// cf. MD 36970..MD36978
// SGE signals in the axis DB, part 1      : DBX22.0 ... DBX23.7
// SGE signals in the axis DB, part 2      : DBX32.0 ... DBX33.7
// In the example, only the interface of axis 1 is described
//
// De-select SBH

```

10.6 Application example with PROFIsafe connection

```
U      "SPL".OIP01_SBH_ABWAHL;
=      DB31.DBX 22.1;

// SG changeover, bit 1
U      "SPL".OIP02_SG_AUSW_B1;
=      DB31.DBX 22.4;

// De-select external STOP A (refer to MD 36977[0])
U      "SPL".OIP03_STOPA_ABW;
=      DB31.DBX 32.2;

// De-select external STOP C (refer to MD 36977[1])
U      "SPL".OIP04_STOPC_ABW;
=      DB31.DBX 32.3;

// De-select external STOP D (refer to MD 36977[2])
U      "SPL".OIP05_STOPD_ABW;
=      DB31.DBX 32.4

NETWORK

TITLE =output external outputs (OUTSEP) to the I/O

// This step is no longer required for PROFIsafe outputs in the user program.
// The A_OUTSEP[n] variables (DB18.DBX46.0 .. DBX54.7) are output via the
// parameterization of the NCK machine data MD 10387[n] and MD 10389[n] from
// the interface in the DB18 (logically "AND'ed" with the associated $A_OUTSE
// variable) directly to the I/O. This means that the output to the I/O is
// carried-out within the system

END_FUNCTION
```

10.6.11 Modified limitations with PROFIsafe

When compared to connecting the SPL I/O with two separate hardware I/O branches (NCK and PLC I/O), when connected via SPL I/O using one safety-related bus (PROFIsafe) results in some modified limitations relating to configuring and programming:

- Faults/errors in the PROFIsafe input devices (e.g. input signals that differ from one another) cause the associated SPL input signals (\$A_INSE(P)) to be deleted (cleared). This initiates a STOP D/E.
- The external SPL input signals in the DB18 interface for the \$A_INSEP variables are transferred within the system. This means that programming is no longer necessary in the user program. The PROFIsafe input I/O now only transfer one signal state to the master for both SPL channels. This means that in the control, there are no longer any crosswise data comparison errors for \$A_INSE(P) variables.
- The external SPL output signals of the DB18 interface (\$A_OUTSEP variables) are transferred within the system to the relevant PROFIsafe output modules. Since only one signal state is transferred via PROFIsafe, it is no longer possible to temporarily output a signal state for the PLC output that is different from that of the NCK output – as implemented previously for exceptional cases. There is now no PLC branch and no NCK branch for safe PROFIsafe output that has a two-channel structure.
- It may be necessary to use single-channel signals (signals that are present only in the PLC or only in the NCK) to change over external SPL outputs (e.g. braking control). This fact means that these single-channel signals must also be made available to the other program channel to align the logic and program synchronously. Direct communications between the NCK and PLC-SPL via DB18 is a good way to achieve this.
- In each PROFIsafe cycle, the PROFIsafe layer generates a PROFIsafe telegram with the logically AND'ed SPL output data as F net (useful) data.

10.7 Conventional brake control (single-channel from the PLC)

Many brake actuation systems still use a PLC output that switches an additional hardware relay. The reason for this is that a standard S7 output can only supply 0.5 A and a current of this magnitude is usually not sufficient to be able to actuate a brake.

This circuit has the following disadvantages:

Firstly, control via the PLC does not comply with the safety requirements (in the worst case, the PLC can crash without resetting the outputs, i.e. the axis could fall). Secondly, the application time of the holding brake is increased because the hardware relay has to be controlled and it also has an associated switching time.

In order to keep the switching time of the contactor as short as possible, neither an interference suppression diode (6 to 10-fold increase in the switching time) nor a diode combination (2 to 6-fold increase in the switching time) may be used for in-

10.7 Conventional brake control (single-channel from the PLC)

interference suppression of the contactor. The only practical solution in this case is a varistor (increase of approximately 2–5ms).

It is better to use an optocoupler or an S7 module, both of which provide an output current of 2A.

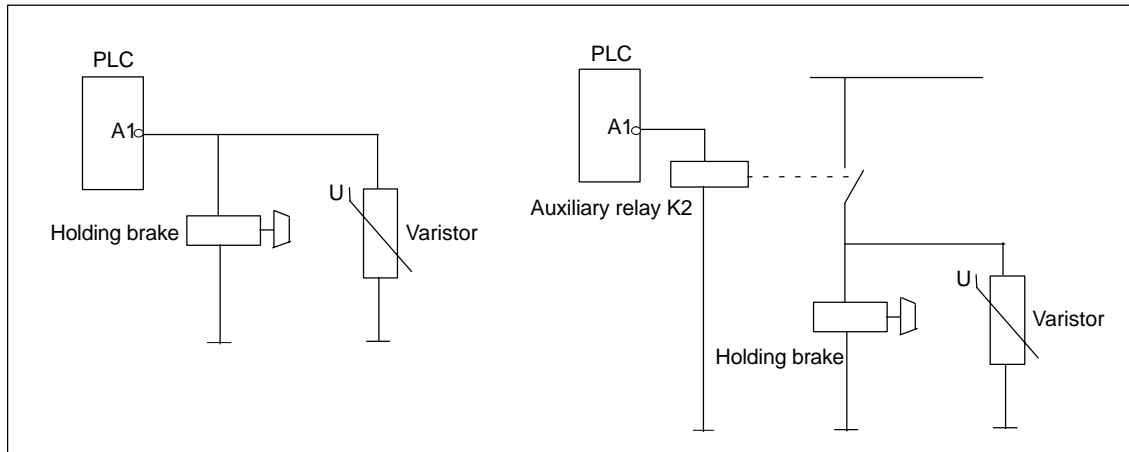

Fig. 10-43 Single-channel brake control, P-switching (single-channel from the PLC)

If this type of brake control is used with Safety Integrated, the STOP A/B active signal (DB3x.DBX 111.4) is available to be logically combined with further criteria to control the brake (for SI with SPL, a significantly more sophisticated brake control function can be implemented, that is described further below).

The "position controller active" signal (DB3x.DBX 61.5) represents a further condition to release the brake. The "speed controller active" signal (DB3x.DBX 61.6) should be used in conjunction with Safety Integrated. This is because when a Stop C is active the position controller is inactive but the speed controller remains active, which would mean that the drive would oppose the brake.

Note

For this type of control, there is a risk that single-channel actuation of the brake or the holding brake may not operate correctly in the event of a PLC fault and that under worst case conditions, the axis could fall.

10.8 Two-channel brake control with SI (SPL)

Description

In order to increase the safety-related quality of the brake control system (for a holding brake or an operating brake), it is necessary to use a two-channel control system. An NCK output switches the P voltage (24V) to release the brake and a PLC output (S7 relay module) switches the M voltage (P/M control). A feedback contact on the PLC side verifies that the two switching elements are operating correctly.

Controlling the NCK output (relevant signals – suggestion):

- "STOP A/B active"
- \$VA_DPE[machine axis name] (status of the power enable – on an axis-for-axis basis)
- Alternatively or additionally, the system variable \$AC_ALARM_STAT (information about queued alarm responses)
- Application-specific SPL signals such as "Emergency Stop not active", "control system not powered-up", etc.

=> Linking these signals to \$A_OUTSE (NCK output)

Controlling the PLC output (relevant signals – suggestion):

Equivalent programming measures should be implemented on the PLC side (up to the \$A_OUTSEP variable), i.e. further shutdown conditions can be integrated to control the output.

- "STOP A/B active"
- SGA "pulses safely cancelled" axis DB.DBX 108.2
- Status signal "pulses enabled" axis DB.DBX 93.7
- Status signal "speed controller active" axis DB.DBX 61.6
- Application-specific SPL signals such as "Emergency Stop not active", "control system not powered-up", etc.

} Refer to
\$VA_DPE

Note

The simulation of the system variable state \$VA_DPE[AXn] using the specified signals is not a complete match in the exceptional case "optimizing the current controller". In this case, the \$VA_DPE[AXn] signal remains at 1, while the signal "speed controller active" is already 0. The reason for this is that only the current controller is still active. If this particular case is relevant, then this must be taken into account in the application in order to achieve a brake test without crosswise data comparison error.

10.8 Two-channel brake control with SI (SPL)

=> Linking these signals to \$A_OUTSEP (DB18 signal)

Signals, that are logically combined after \$A_OUTSEP to control the PLC output no longer influence the SPL crosswise data comparison. Additional signals can include the following:

- User signals, e.g. "test stop active"
- Status signal "position controller active", axis DB.DBX 61.5 for possibly faster application of the brake
- Status signal "NCK-CPU ready", DB10.DBX 104.7 for a possible faster brake closing time when suitably configuring the FB1 parameter "NCCyclTimeout" (standard value is sufficient)

=> Linking these signals to the PLC output

Example

NCK part

(1) Machine data

```
MD 36990[0]   SAFE_ACT_STOP_OUTPUT = 04010101 (for drive X1)
```

(2) SPL

```
DEFINE STOP_A_B_aktiv      AS $A_INSI[1]
DEFINE P_BREMSE_X1        AS $A_OUTSE[1]
DEFINE NOT_HALT_nicht_aktiv AS $A_MARKERSI[1]
IDS=1 DO P_BREMSE_X1 = NOT STOP_A_B_aktiv AND $VA_DPE[X1]
                AND NOT_HALT_nicht_aktiv
```

PLC part

```
U   DB31.DBX111.4          // STOP A/B active
=   DB18.DBX54.0           // $A_INSI[1]
UN DB18.DBX54.0           // $A_INSI[1]
UN DB31.DBX108.2         // SGA pulses not safely cancelled
U   DB31.DBX93.7        // Pulses enabled
U   DB31.DBX61.6          // Speed controller active
U   DB18.DBX70.0          // Emergency Stop not active
=   DB18.DBX46.0          // $A_OUTSEP[1]

U           DB18.DBX46.0   // $A_OUTSE[1]
U           DB31.DBX61.5   // Position controller active - from here
                                onwards, no longer any effect on SPL
                                crosswise data comparison
U           DB10.DBX104.7 // NCK-CPU ready
.
.
= A2.0          // PLC output, relay module (M potential)
```

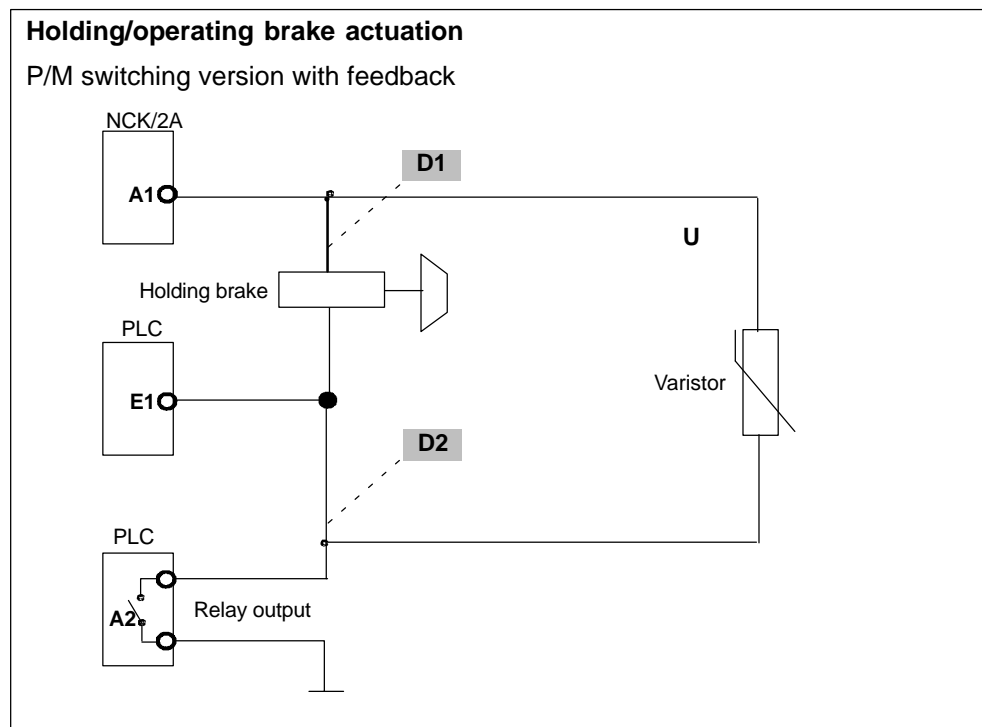

Fig. 10-44 Two-channel brake control, P/M switching with SI

Unlike the test routine described in Chapter 10.3 the test involves separately controlling the two outputs A1 and A2 and monitoring the resulting signal level change at test input E1.

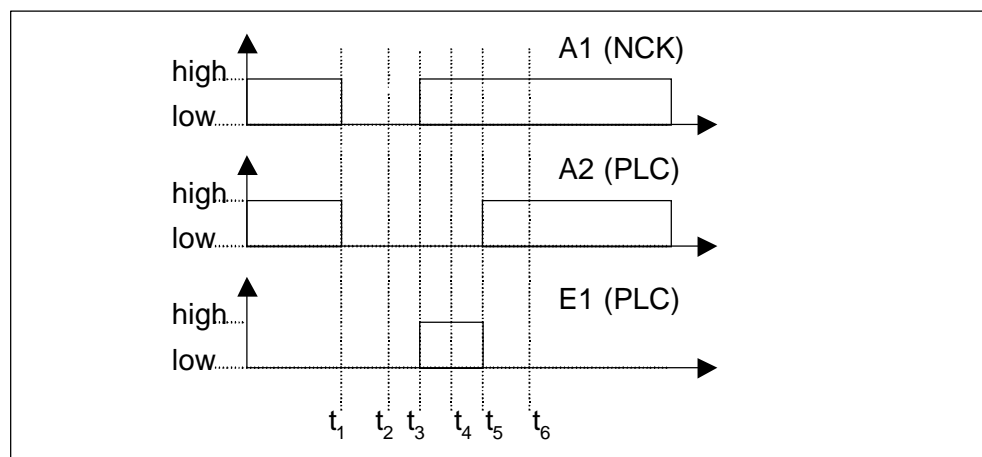

Fig. 10-45 Test routine at power-on

Description

The check can be incorporated in the standard test routine (Chapter 7.3.4) or separately executed. The test sequence is shown in the following sequence chart (flowchart).

Note

The feedback signal input E1 (PLC) to test the two-channel brake control is only briefly at "1" for a non-symmetrical shutdown – this is correct.

This feedback signal input is only conditionally suitable to test the mechanical braking system (refer to Chapter 10.9). The feedback signal input status expected from FB11 must then be a (continuous) "1" if the brake is closed. The feedback signal input E1 supplies a 0 if, according to Fig. 10-45 the controlled brake is connected through two channels for the test.

This means that either the brake is only closed through one-channel (via the PLC output) if the control for the mechanical braking test was previously made → E1 = 1 or the feedback signal input for the FB11 is simulated ("1" signal when the brake is closed).

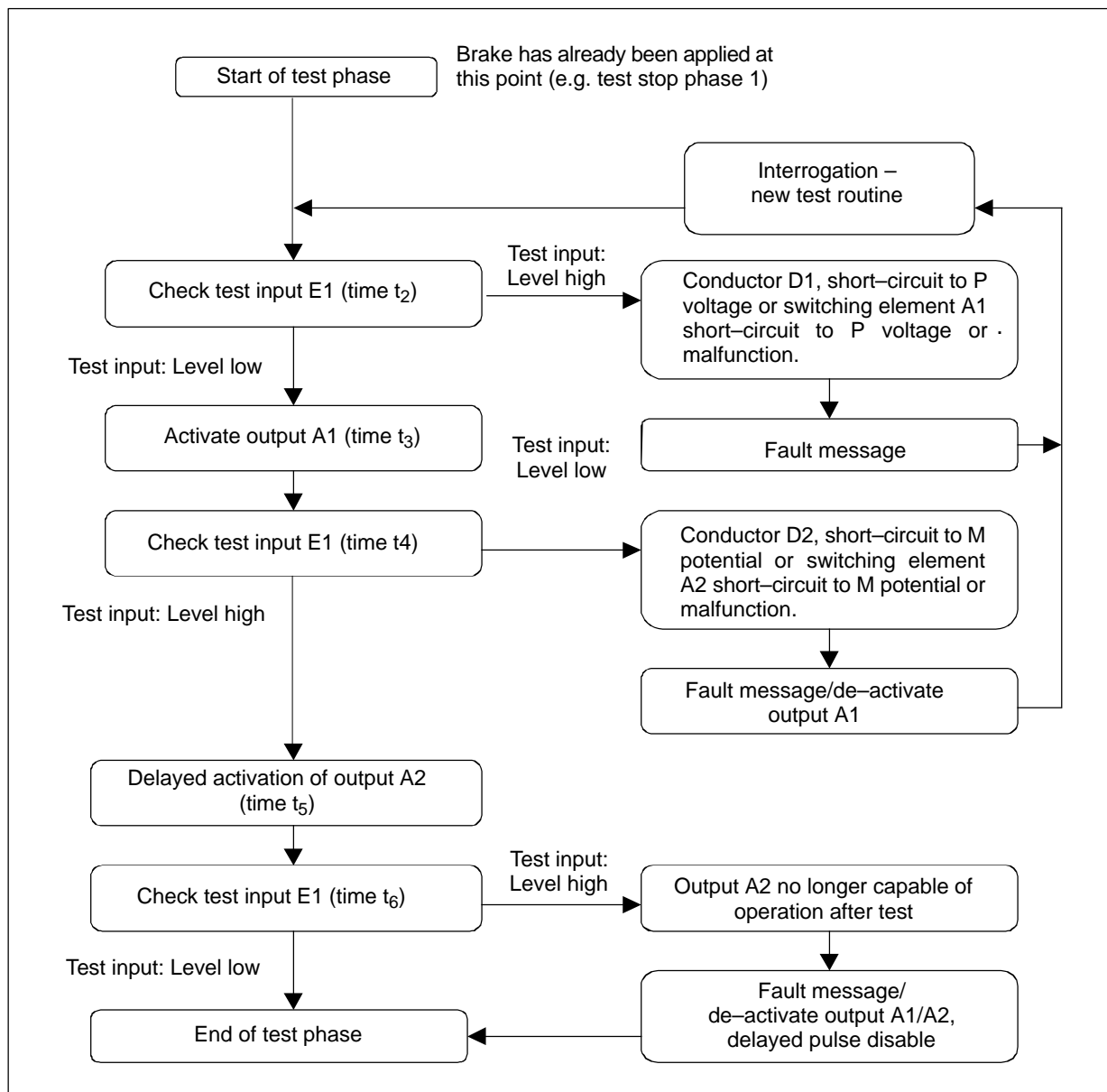

Fig. 10-46 Flowchart for the test routine

Description

With this safe brake control, only the operating brake represents a potential hazard.

10.9 Safe brake test (SBT)

10.9.1 Applications

The mechanical braking system test should be used for all axes which must be prevented from moving in an uncontrolled manner by a holding brake. This test function is primarily intended for so-called "vertical axes". The brake test fulfills the requirements of control Category 2 according to EN 954–1.

The functionality is based on "traversing to a fixed endstop". The traversing to a fixed endstop can be individually parameterized to test the function of the mechanical braking system. It is activated and de-selected from the PLC. For further details on traversing to a fixed endstop, refer to /FB1/, F1.

The machine manufacturer can use his PLC user program to close the brake at a suitable instant in time (nominal value, every 8h similar to the SI test stop) and initiates the drive to produce an additional force in addition to the weight of the axis. In a fault-free state, the brake can apply the necessary force, i.e. the axis will hardly move.

When there is a fault condition, the actual position value leaves the parameterizable monitoring window. In this case, traversing to fixed endstop is terminated so that the position controller can prevent the axis falling. The brake test is then negatively acknowledged.

The brake test must always be started when the axis is at a standstill (also refer to Chapter 10.9.5 "Activation"). The direction in which the drive produces its force is specified by the PLC using a "traversing motion" via FC 18. The target of this traversing motion must be able to be reached without incurring any potential hazard for the case that the brake cannot provide the necessary force.

10.9.2 Parameterization

The user can use the following axial NCK machine data to parameterize the function test of the mechanical braking system:

- \$MA_FIXED_STOP_MODE
- \$MA_FIXED_STOP_THRESHOLD
- \$MA_SAFE_BRAKETEST_TORQUE
- \$MA_SAFE_BRAKETEST_POS_TOL
- \$MA_SAFE_BRAKETEST_CONTROL

\$MA_FIXED_STOP_MODE

The function test of the mechanical braking system is enabled by setting bit 1 in \$MA_FIXED_STOP_MODE. If the user needs to travel to a fixed endstop with this axis from the part program, bit 0 can also be set. It is internally monitored to check that only one type of traverse to fixed endstop is active at a time. In the case of an error, Alarm 20092, "Axis % 1 Travel to fixed endstop still active" is issued.

\$MA_SAFE_BRAKETEST_TORQUE

The machinery construction OEM must parameterize the total required brake holding torque in the axial MD \$MA_SAFE_BRAKETEST_TORQUE. Internally, this is used to calculate the drive torque that is required in addition to the weight of the axis to load the brake.

For SIMODRIVE 611 digital the drive is determined when the function test is selected. This means that it is possible to take into account a deviation from the torque due to weight (or force due to weight) parameterized in the drive machine data 1192 FORCE_LIMIT_WEIGHT. This ensures that the brake test can also be carried-out with varying machine loads (e.g. different workpieces or tools). The drive torque to load the holding brake is limited to the maximum motor torque if the desired braking torque would require a higher drive torque.

If the load torque at an axis changes so significantly that a sensible value cannot be parameterized in MD 1192, then the automatic determination of the load torque available must be activated using \$MA_SAFE_BRAKETEST_CONTROL.

10.9 Safe brake test (SBT)

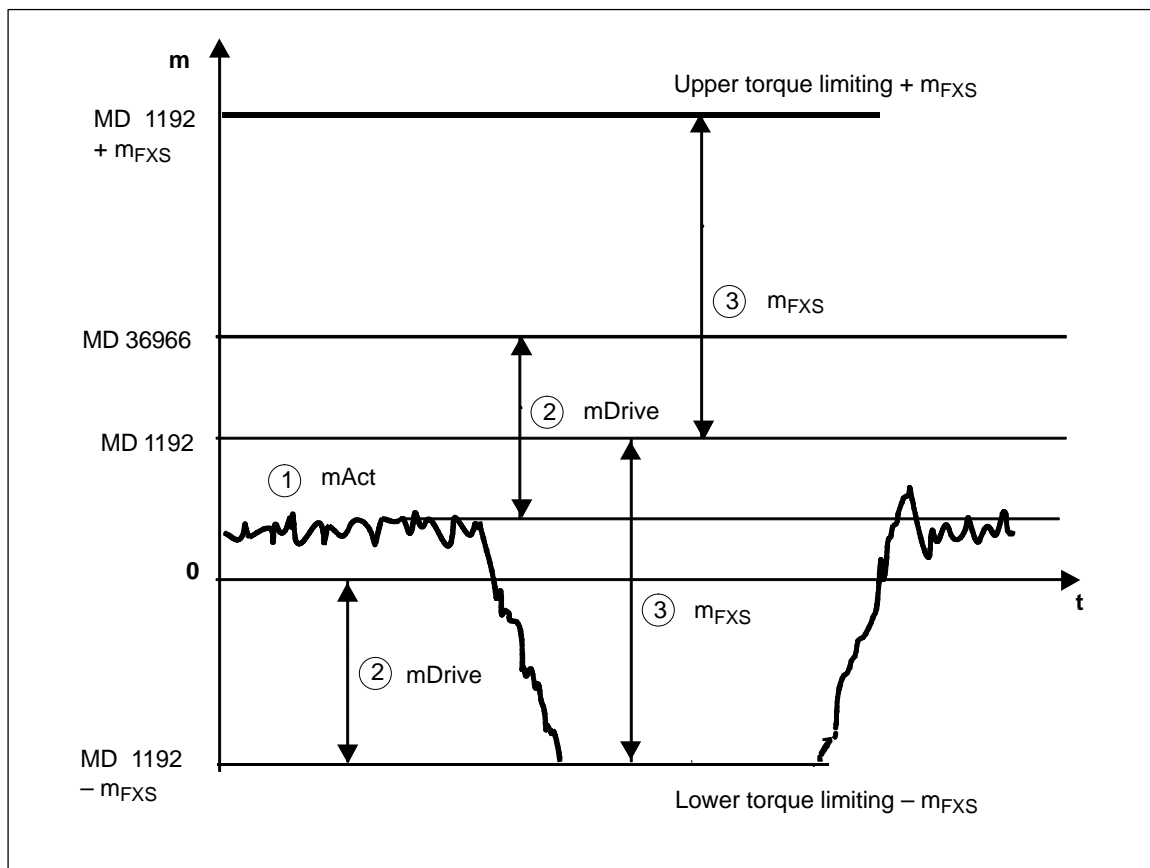

Fig. 10-47 Torque limiting for 611digital

①

When selecting the brake test, the holding torque required for the force due to the weight of the axis is internally measured (m_{Act}).

②

The drive must only additionally provide the difference between this torque and the braking torque from MD 36966 $\$MA_SAFE_BRAKETEST_TORQUE$. In the diagram 10-47, this torque is designated with m_{Drive} .

③

The torque limiting of the SIMODRIVE 611digital drive is symmetrical around the torque from the drive machine data 1192.

This is the reason that m_{FXS} from Fig. 10-47 is entered as torque limiting. m_{FXS} is the sum of m_{Drive} and MD 1192. If the measured torque m_{Act} matches that parameterized in MD 1192, then m_{FXS} is added to the value from MD $\$MA_SAFE_BRAKETEST_TORQUE$.

Incorrect parameterization in MD $\$MA_SAFE_BRAKETEST_TORQUE$ or drive machine data 1192 could mean that the drive with reduced torque cannot even apply the required holding torque. This parameterization is detected when the

brake test is selected and results in Alarm 20095 (refer to Chapter 6). The fact that the actual torque/force setpoint is displayed in MD 1728 makes it easier to correctly parameterize drive machine data 1192. If only the force due to the weight is effective, then this value can be directly transferred into MD 1192. This value must be entered – with an additional safety margin – into MD \$MA_SAFE_BRAKETEST_TORQUE. The magnitude of the safety margin is orientated to the maximum holding force of the brake to be tested.

Example:

The force due to weight of the vertical axis is 4000 N, the braking force that has to be guaranteed is 6000 N. On account of the weight of the axis, a torque of 32% of the holding torque of the motor is obtained and this is displayed in MD 1728.

Therefore 32% must be parameterized in MD 1192. The correct value for \$MA_BRAKETEST_TORQUE is obtained as follows:

$$\text{\$MA_SAFE_BRAKETEST_TORQUE} = 32\% * 6000\text{N} / 4000\text{N} = 48\%$$

In addition, the electronic weight equalization should be parameterized in the axial NCK–MD 32460: \$MA_TORQUE_OFFSET. This means that the necessary holding torque is re-established much faster when the brake is released (the brake is opened).

\$MA_SAFE_BRAKETEST_CONTROL

Some machines have braked axes whose load torque can vary significantly over the complete traversing range or depending on the workpiece or tool being used. If the drive cannot be parameterized for all of the situations using MD 1192, an automatic determination of the load torque present at the start of the braking test can be activated using MD 36968 \$MA_SAFE_BRAKETEST_CONTROL. If bit 0 of \$MA_SAFE_BRAKETEST_CONTROL is set to 1, then the torque, determined at the start of the brake test (mAct from Fig. 10-47 or Fig. 10-48) is temporarily used as average value for the torque limiting in the drive.

The user must carefully ensure that the brake is not previously closed thus preventing an incorrect load torque being determined. This would then mean that the brake test would be carried-out with an incorrect torque. The load torque is then no longer checked for plausibility. This function should only be activated if it isn't possible to sensibly parameterize MD 1192.

\$MA_SAFE_BRAKETEST_POS_TOL

The monitoring window for the maximum permissible movement during the brake test is defined in the axial MD \$MA_SAFE_BRAKETEST_POS_TOL. The PLC actively monitors this position window – from the start of the brake test and not only when it has been detected that the fixed endstop has been reached. This is a difference when compared to activating the traversing to the fixed endstop function from the part program.

10.9 Safe brake test (SBT)

\$MA_FIXED_STOP_THRESHOLD

The contour deviation that is determined is always used in the brake test to detect that the fixed endstop has been reached. The parameterization in \$MA_FIXED_STOP_BY_SENSOR is therefore irrelevant. The required threshold value must be set in MD \$MA_FIXED_STOP_THRESHOLD. This means that the traversing distance from the PLC via FC 18 must be greater than this threshold value. Furthermore, the drive must have reached its torque limit parameterized using \$MA_SAFE_BRAKETEST_TORQUE.

10.9.3 Sequence

The brake test in the PLC is carried-out by calling data block FB11 (from the basic program) from the user program. The brake test comprises the following steps:

Step	Expected feedback	Monitoring time value
Start brake test	DBX 71.0 = 1	TV_BTactiv
Close brake	Bclosed = 1	TV_Bclose
Output traversing command	DBX 64.6 Or DBX 64.7	TV_FeedCommand
Check, output traversing command	DBX62.5 = 1	TV_FXSreached
Wait for the holding time	DBX62.5 = 1	TV_FXShold
De-select brake test/open brake	DBX71.0 = 0	TV_BTactiv
Output test ok		

Function_Block FB 11

Declaration of the function:

```

VAR_INPUT
  Start : BOOL ;           //Start of the brake test
  Quit : BOOL ;           //Acknowledge fault
  Bclosed : BOOL ;        //Brake closed input (single channel – PLC)
  Axis : INT ;            //Testing axis No.
  TimerNo : TIMER ;       //Timer from user
  TV_BTactiv : S5TIME ;   //TimeValue -> brake test active
  TV_Bclose : S5TIME ;    //TimeValue -> close brake
  TV_FeedCommand : S5TIME ; //TimeValue -> force FeedCommand
  TV_FXSreached : S5TIME ; //TimeValue -> Fixed stop reached
  TV_FXShold : S5TIME ;   //TimeValue -> test brake
END_VAR

VAR_OUTPUT
  CloseBrake : BOOL ;     //Signal close brake
  MoveAxis : BOOL ;       //do move axis
  Done : BOOL ;
  Error : BOOL ;
  State : BYTE ;          //Error byte
END_VAR

```

The following table lists all of the formal parameters of the brake test function:

Signal	Type	Type	Comment
Start	I	BOOL	Starts the brake test
Quit	I	BOOL	Acknowledge fault
Bclosed	I	BOOL	Feedback input whether a control signal has been issued to close the brake (single-channel PLC)
Axis	I	INT	Axis number of axis to be tested
TimerNo	I	TIMER	Timer from user program
TV_BTactiv	I	S5TIME	Monitoring time value -> close brake. Check the axis signal DBX71.0
TV_Bclose	I	S5TIME	Monitoring time value -> close brake. Check the input signal Bclosed after the CloseBrake output was set.
TV_FeedCommand	I	S5TIME	Monitoring time value -> output traversing command. Check traversing command after MoveAxis has been set.
TV_FXSreached	I	S5TIME	Monitoring time value -> fixed endstop reached
TV_FXShold	I	S5TIME	Monitoring time value -> test brake
CloseBrake	O	BOOL	Request, close brake
MoveAxis	O	BOOL	Request, initiate traversing motion
Done	O	BOOL	Test successfully completed

10.9 Safe brake test (SBT)

Signal	Type	Type	Comment
Error	O	BOOL	Fault/error has occurred
State	O	BYTE	Fault status

Fault IDs

State	Meaning
0	No fault
1	Start conditions not fulfilled, e.g. the axis is not in closed-loop control/brake closed/axis inhibited
2	When the brake test is selected, no NC feedback in the "brake test active" signal

Causes:

- The brake test function has still not been enabled using MD 37000 \$MA_FIXED_STOP_MODE (bit 1 = 1).
- For the torque measurement and the comparison with the selected test torque value (MD 36966 \$MA_SAFE_BRAKETEST_TORQUE), a plausibility error was detected (refer to Alarm 20095).

State	Meaning
3	No feedback signal "brake applied" using the input signal BClosed
4	No traversing command output (e.g. axis motion has not been started)
5	Fixed endstop is not reached -> axis RESET was initiated
6	Traversing inhibit/approach too slow -> fixed endstop cannot be reached. Monitoring time TV_FXSreached has expired.
7	Brake is not holding at all (the end position is reached)/approach speed is too high
8	Brake opens during the holding time
9	Fault when de-selecting the brake test
10	Internal fault
11	"PLC-controlled axis" signal not enabled in the user program

Alarm number 41101

Meaning: Parameter, axis not in the permissible range
 Remedy: Use the permissible axis number

Note

The user program must call the block. The user must provide an instance DB with any number for this purpose. The call is multi-instance-capable.

Example of calling FB11

```

UN M    111.1;           //Request close Z axis brake from FB
=  A    85.0;           //Control Z axis brake

AUF  "Axis3";           //Test, Z axis brake

O  E    73.0;           //Initiates the brake test, Z axis
O  M    110.7;          //Brake test running
FP  M    110.0;
UN  M    111.4;          //Fault has occurred
S  M    110.7;          //Brake test running
S  M    110.6;          //Next step
S  DBX   8.4;           //Request neutral axis
U  DBX  68.6;           //Feedback signal, axis is neutral
U  M    110.6;
FP  M    110.1;
R  M    110.6;
S  M    110.5;          //Next step
R  DBX   8.4;
S  DBX  28.7;           //Request, PLC monitored axis
U  DBX  63.1;           //Feedback signal, the PLC is monitoring the axis
U  M    110.5;
FP  M    110.2;
R  M    110.5;
S  M    111.0;          //Start the brake test for FB

CALL FB  11 , DB  211 //Brake test block
  Start      := M  111.0, //Start brake test
  Quit  := E    3.7, //Acknowledge fault with Reset key
  Bclosed   := E  54.0, //Feedback signal, control signal has been output
                    to close the brake
  Axis  := 3, //Axis number of axis to be tested, Z axis
  TimerNo      := T  110, //Timer number
  TV_Btactiv  := S5T#200MS, //Monitoring time value: Brake test active DBX71.0
  TV_Bclose   := S5T#1S, //Monitoring time value: Brake closed
  TV_FeedCommand := S5T#1S, //Monitoring time value: Traversing command
                    output
  TV_FXSreached := S5T#1S, //Monitoring time value: Fixed endstop reached
  TV_FXShold   := S5T#2S, //Monitoring time value: Test time brake
  CloseBrake   := M  111.1, //Request, close brake
  MoveAxis     := M  111.2, //Request, initiate traversing motion
  Done         := M  111.3, //Test successfully completed

```

10.9 Safe brake test (SBT)

```

Error          := M 111.4, //Fault has occurred
State          := MB 112); //Fault status

AUF           "Axis3"; //Brake test, Z axis

O   M   111.3;      //Test successfully completed
O   M   111.4;      //Fault has occurred
FP  M   110.3;
R   DBX 28.7;      //Request, PLC monitored axis

UN  DBX 63.1;      //Feedback signal, the PLC is monitoring the axis
U   M   111.0;      //Start brake test for FB
U   M   110.7;      //Brake test running
FP  M   110.4;
R   M   111.0;      //Start brake test for FB
R   M   110.7;      //Brake test running

CALL "SpinCtrl" (//Traverse Z axis
  Start := M 111.2, //Start traversing motion
  Stop  := FALSE,
  Funct:= B#16#5, //Mode: Axis mode
  Mode  := B#16#1, //Traversing: Incremental
  AxisNo      := 3, //Axis number of the axis to be traversed Z axis
  Pos   := -5.000000e+000, //Distance travelled: minus 5 mm
  Frate  := 1.000000e+003, //Feed rate: 1,000 mm/min
  InPos  := M 113.0, //Position reached
  Error  := M 113.1, //Fault has occurred
  State  = MB 114); //Fault status

```

10.9.4 Limitations/secondary conditions

During the brake test, traversing to fixed endstop and/or traverse with limited torque FOC may not be active at the same time. In this case, Alarm 20092, "Axis %1 travel to fixed stop still active" is triggered.

During the brake test, contour monitoring is not active. After the PLC has started traversing motion then there is also no standstill monitoring.

The brake test is only possible for SIMODRIVE 611digital. It cannot be used for gantry axes.

If the parameterization of MD 1192 (> 5%) deviates from the measured torque at the start of the brake test – then the brake test must be carried-out in the same direction in which the load torque is effective. In the case of a fault – Alarm 20097 "Axis %1 incorrect brake test direction" is output.

10.9.5 Activating

The brake test must always be started when the axis is at a standstill. For the entire duration of the brake test, the enable signals of the parameterized axis must be set to enable (e.g. the controller inhibit, feed enable signals). The signal "PLC-controlled axis" (DB "Axis".DBX28.7) must still be set to 1 by the user program for the entire duration of the test. Prior to activating the signal "PLC controlled axis", the axis must be set as "neutral axis", e.g. set byte 8 in the axis DB to channel 0. Set the activating signal in the same byte. The block may not be started until the NC feedback signal has been received via the appropriate bit (DB "Axis".DBX63.1). For a PLC-monitored axis, also refer to:

References: /FB2/ P2 "Autonomous single-axis processes (SW 6.3 and higher)"

10.9.6 Examples

An example of incorrect parameterization that results in Alarm 20095, "Axis %1 impermissible holding torque, measured torque %2" is shown in the following diagram: The torque due to weight in the drive machine data 1192 has been parameterized considerably lower than the measured torque m_{Act} . The calculated torque limit m_{FXS} , positioned symmetrically around this MD, would mean that the drive would not be able to produce the required holding torque for this axis ($MD1192 + m_{FXS}$ is lower than m_{Act}).

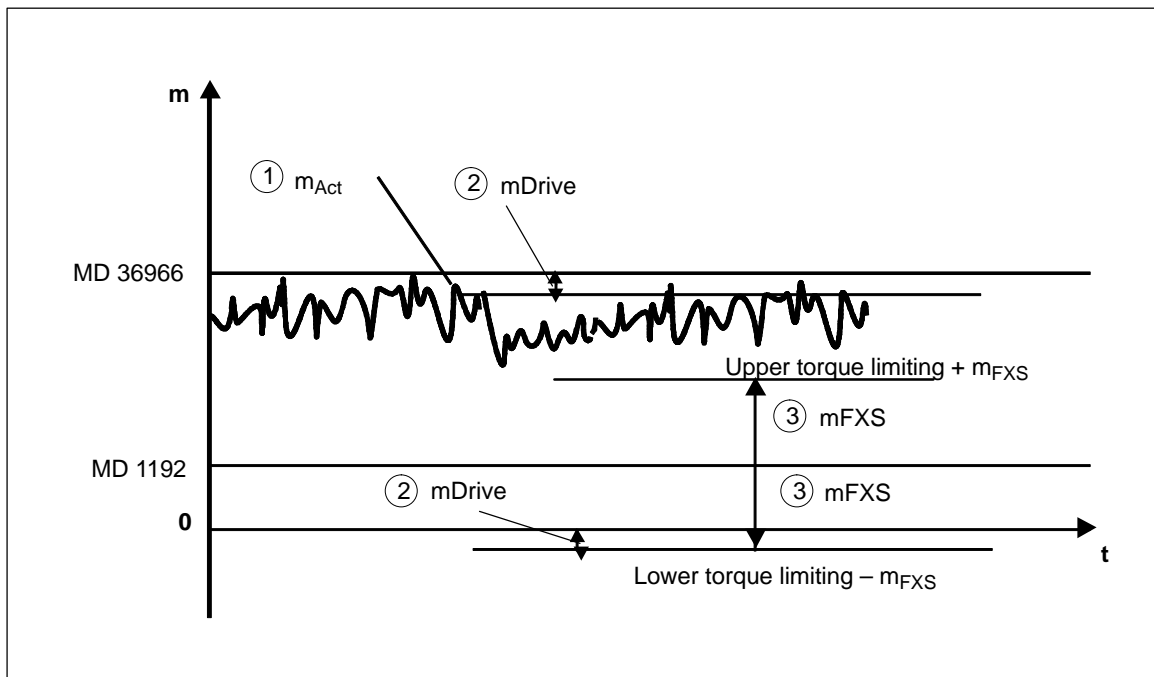

Fig. 10-48 Example of incorrect parameterization

10.9 Safe brake test (SBT)

If MD 1192 cannot be sensibly parameterized for all situations where the brake test is to be carried-out, then the automatic determination of the load torque must be activated using MA_SAFE_BRAKETEST_CONTROL.

Start-up (commissioning)

To support the commissioning of the brake test Alarm 20096, "Axis %1 brake test aborted, additional info %2" can be enabled using bit 5 in machine data \$MN_ENABLE_ALARM_MASK. This alarm supplies detailed information if the brake test is interrupted.

10.10 Safe cams at the modulo limit

Description

A problem frequently encountered with machine tools and production machines is the reliable detection of the position of a drive. Safe cams (SN) are used for this purpose. However, it should be noted that the signal level of a safe cam changes at the modulo limit of a rotary axis. The following spindle application illustrates the problem:

General position detection (can be applied to linear axes)

For the rotary axis, the 90° position is to be safely detected. A cam signal is to be generated for this purpose, that has a high signal level between 89.5° and 90.5° (pulse).

These positions are entered into the machine data

36936	SAFE_CAM_POS_PLUS[0] :	90.5 degrees
36937	SAFE_CAM_POS_MINUS[0] :	89.5 degrees
36905	SAFE_MODULO_RANGE :	360 degrees

and are subsequently transferred into the FD/MSD machine data. The following signal level change is obtained for the SN signals:

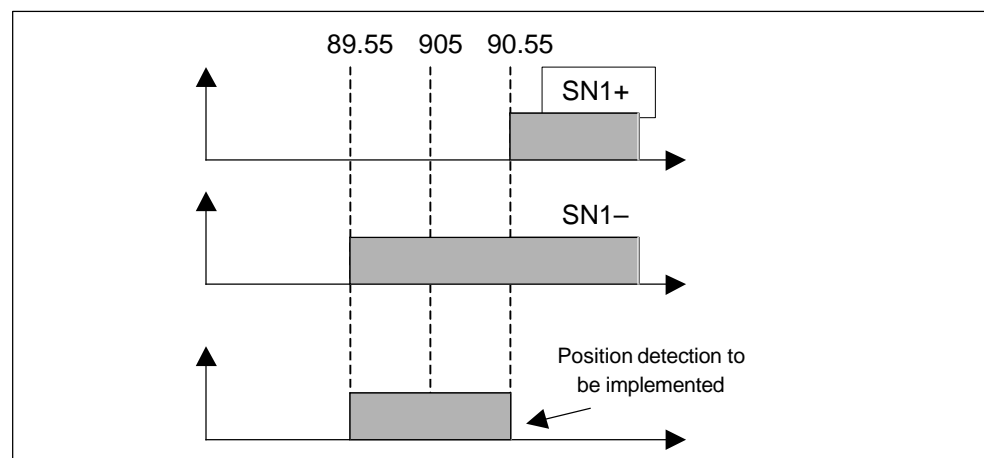

Fig. 10-49 Safe cam signal characteristics

Safe cams SN1+ to SN4- are individual position signals with a signal change from "low" to "high" at the saved position. The required cam signal is generated by negating signal SN1+ and rounding it with signal SN1-.

10.10 Safe cams at the modulo limit

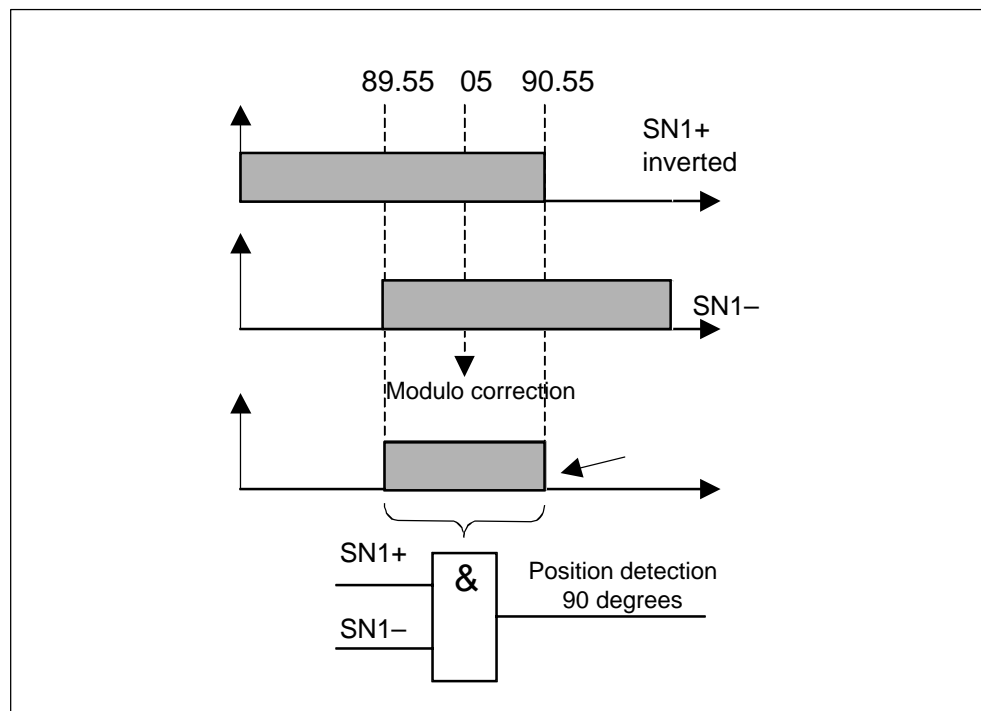

Fig. 10-50 Negating an SN signal to generate a pulse

The appropriate machine data settings are used to negate SN1+ and round-off on the NCK side. To implement this, the two cam signals should be assigned to an NCK output

```

36988     SAFE_CAM_PLUS_OUTPUT[0]  81040101
36989     SAFE_CAM_MINUS_OUTPUT[0] 01040101
or a system variable ($A_INSI[1])
36988     SAFE_CAM_PLUS_OUTPUT[0]  84010101
36989     SAFE_CAM_MINUS_OUTPUT[0] 04010101

```

The minimum logic (Chapter 5.9.1) of the NCK safety channel is used for multiple assignment to an output or a system variable. This includes the rounding-off of the assigned signals.

This type of logic is not available in the form of parameter settings on the PLC side. The negation on the NC side is not effective for the drive (PLC) side, therefore the position detection has to be programmed as shown below:

```

UN   DB3x.DBX109.0      // SN1+
U    DB3x.DBX109.1      // SN1-
=    M1.0                // Position detection 90° in marker 1.0
=    DB18.DBX54.0       // $A_INSI[1]
                        // Position detection 90°

```

Position detection at modulo limit with and without SPL

At the modulo limit, the cams respond differently to that described under Point 1) because of the modulo correction.

The following positions are saved in the machine data:

36936 SAFE_CAM_POS_PLUS[0] : 0.5 degrees
 36937 SAFE_CAM_POS_MINUS[0] : 359.5 degrees
 36905 SAFE_MODULO_RANGE : 360 degrees

The following signal level change is obtained for the SN signals:

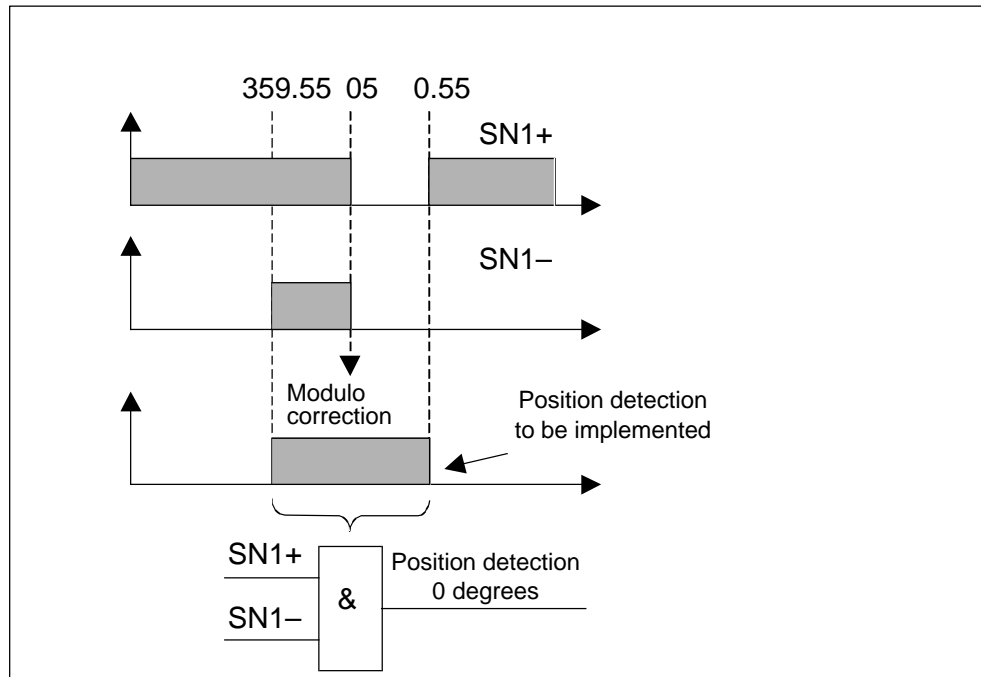

Fig. 10-51 Signal generator for modulo cam 1

Because of the modulo correction and the associated signal level changes of the safe cams, the above method of rounding-off would have the effect that "position detection 0 degrees" would always be a low signal.

This problem can be solved by negating signal SN1+ in the machine data parameterization and OR'ing it with signal SN1-.

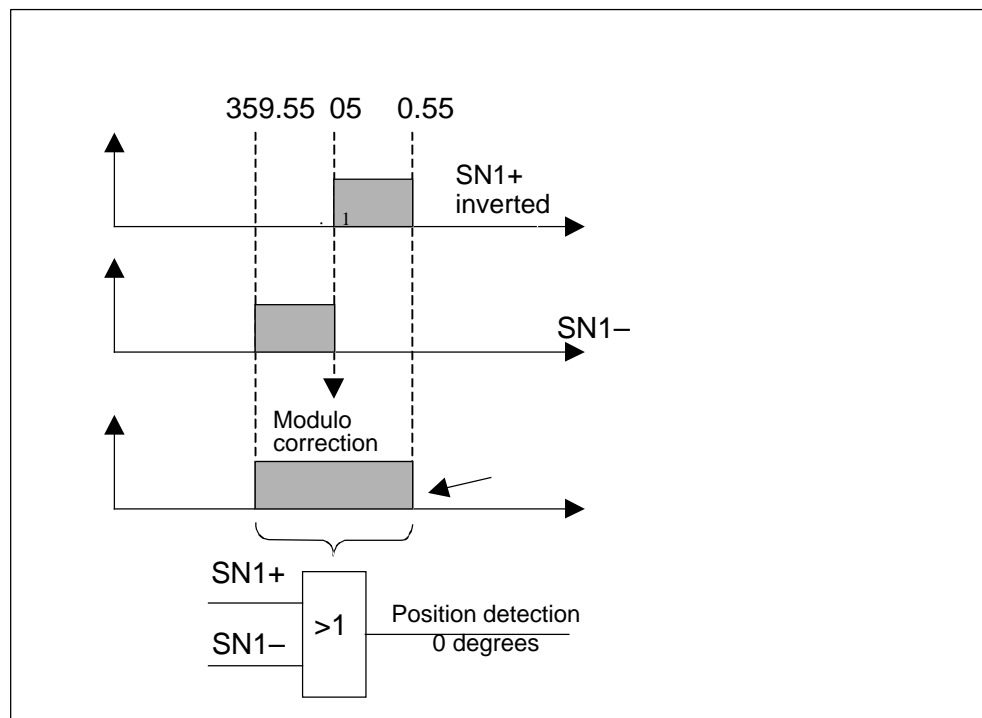

Fig. 10-52 Signal generator for modulo cam 2

However, the OR operation is not integrated in the system and must be implemented in the SPL or by using the appropriate hardwiring.

With SPL, the two cam signals are assigned to $\$A_INSI$ variables and logically combined in the SPL.

```
36988 SAFE_CAM_PLUS_OUTPUT[0] 84010101 ($A_INSI[1]
36989 SAFE_CAM_MINUS_OUTPUT[0] 04010102 ($A_INSI[2])
IDS=1 DO $A_MARKERSI[1] = $A_INSI[1] OR $A_INSI[2]
```

PLC programming is essentially the same as that of the NCK SPL.

```
UN DB3x.DBX109.0 // SN1+ inverted
= DB18.DBX62.0 // $A_INSI[1]
//
U DB3x.DBX109.1 // SN1-
= DB18.DBX62.1 // $A_INSI[2]
//
U DB18.DBX62.0 // $A_INSI[1]
O DB18.DBX62.1 // $A_INSI[2]
= DB18.DBX72.0 // Position detection 0 degrees
// $A_MARKERSIP[1]
```

Without SPL, the SN1+—cam is negated and assigned to an output. The SN1 cam is also assigned to a separate output.

```
36988 SAFE_CAM_PLUS_OUTPUT[0] 81040101
36988 SAFE_CAM_MINUS_OUTPUT[0] 01040102
```

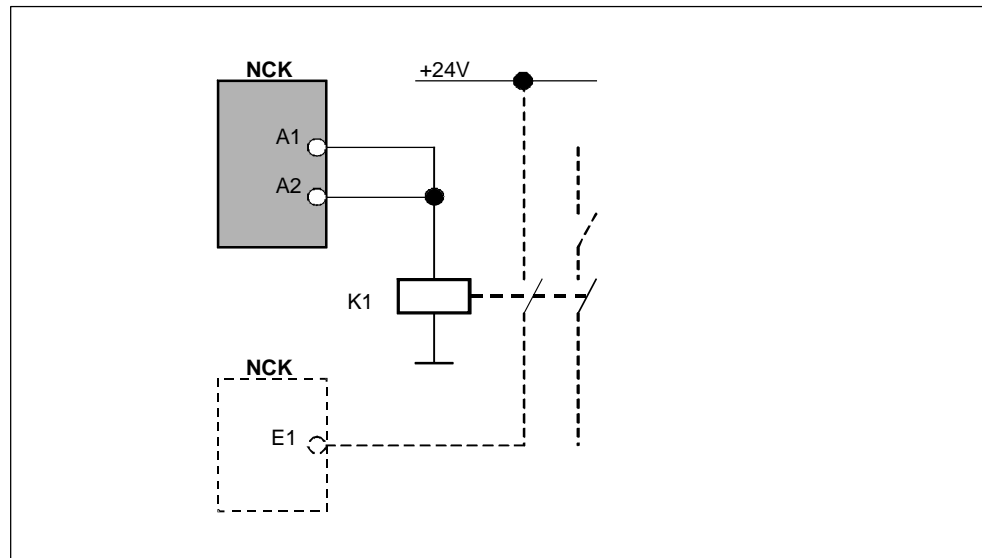

Fig. 10-53 Signal generator for modulo cam 3

In this case, the OR logic operation is implemented by wiring the two outputs to a contactor whose contacts can be used for further processing or can be logically combined with other signals.

The signals are logically combined in the PLC in the usual manner:

```
UN    DB3x.DBX109.0    // SN1+
O     DB3x.DBX109.1    // SN1-
=     M2.0              // Position detection 0°
```

Cam synchronization

Cam synchronization can also be activated for position monitoring, in order that the two safety channels are switched in synchronism (also refer to Section 5.7).

This synchronization is absolutely necessary if the safe cam signals are to be processed in the SPL.

Consideration should be given to conditions which can influence the parameter settings and the effect of synchronization on position detection.

The position of the safe cams at the modulo limit must be aligned to the selected cam tolerance. The calculations shown here are also performed by the Safety Integrated system and, in the event of a parameter error, Alarm:

27033 Parameterization of machine data 36936/36937 [0–3] invalid is displayed.

The following machine data is assumed for the calculations below:

```
36942 SAFE_POS_TOL :    0.1mm
36940 SAFE_CAM_TOL  :    0.1mm
```

10.10 Safe cams at the modulo limit

Example 1 (rotary axes)

$SN1+ \geq \text{lower modulo value} + \text{SAFE_POS_TOL}$

$SN1+ \geq 359.999^\circ + 0.1^\circ$

$SN1+ \geq 0.099^\circ$

Cam $SN1+$ must be greater than or equal to 0.099° .

$SN1- < \text{upper modulo value} - \text{SAFE_POS_TOL} - \text{SAFE_CAM_POS_TOL}$

$SN1- < 0^\circ - 0.1^\circ - 0.1^\circ$

$SN1- < 359.8^\circ$

Cam $SN1-$ must be less than 359.8° .

When using the cam tolerance, it should be noted that the switching position of the cam signal – generated from switching signals $SN1+$ and $SN1-$ – varies according to the traversing direction, the magnitude of the tolerance, and the magnitude of the position deviations.

Example 2 (linear axis, pulse generation)

For a cam position of 100 mm and the following tolerances,

36942 `SAFE_POS_TOL`: 0.1 mm (max. static deviation)

36940 `SAFE_CAM_POS_TOL` : 0.1 mm

36936 `SAFE_CAM_POS_PLUS[0]`: 100 mm ($SN+$)

36037 `SAFE_CAM_POS_MINUS[0]`: 99 mm ($SN-$)

`POSITION NCK` at 0 mm : 0.000 mm

`POSITION drive` at 0 mm : 0.040 mm

(static deviations of actual values 0.040 mm)

then when the cam tolerance is active, the following switching characteristics are obtained for the individual channels and the characteristics of the synchronized signal.

Further, the following diagram shows how a pulse signal is generated from two synchronized cam signals (schematic distances).

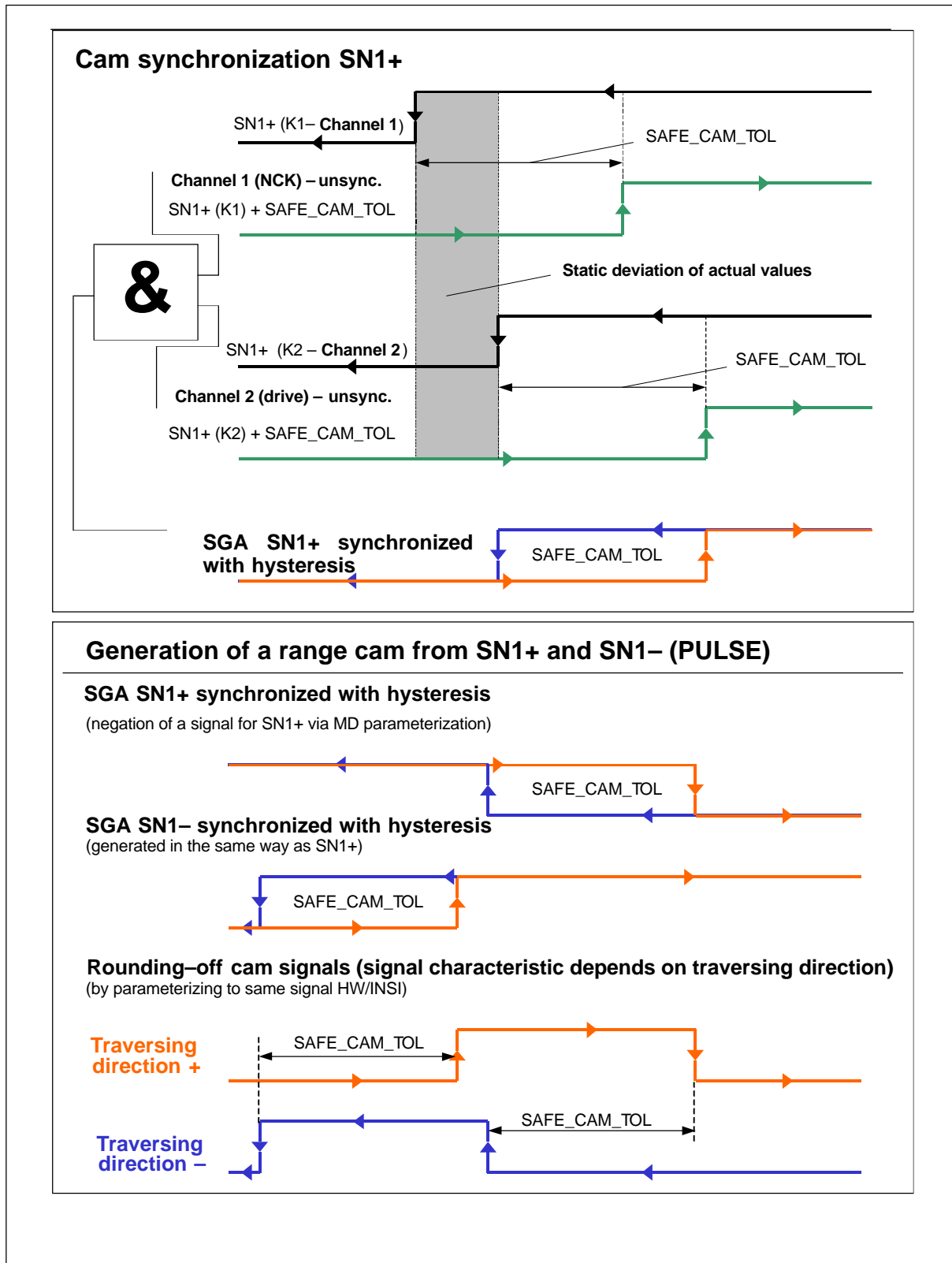

Fig. 10-54 Signal generator for modulo cam 2

10.11 SPL functionality without real drives

As can be seen in the diagram, the setting of machine data MD_SAFE_CAM_TOL determines the following quantities:

- Magnitude of the hysteresis (for a synchronized cam signal)
- Magnitude of the offset (that depends on the traversing direction) of the pulse generated from two cam signals

10.11 SPL functionality without real drives

Description

This example is intended to illustrate how to commission "Safety Integrated" with SPL functionality using the "parking axis" function (i.e. where a position measurement system is not active).

The motor and measuring system connections on the drive can remain disconnected.

This option is suitable for commissioning external peripheral devices (hydraulic systems, chip conveyors, etc.), which require the safety functions of the SPL logic, or for a test set-up, to configure and test the SPL logic in a preliminary phase (e.g. Emergency Stop).

Note

The SE (safe limit positions) and SN (safe cams) functions cannot be tested in this example since there are no real actual values.

1. Run-up the NCK with the standard machine data by selecting key position S3=1 followed by power on.
2. Set switch S3 back to position 0.
3. The password for protective stage 2 = "Machine manufacturer" must be active.
4. **Alternative 1:** Download an NC archive file with an existing drive configuration => (continue with Point 11)
5. **Alternative 2:** Commission one or more axes
 - Drive configuration softkey
 - Insert module softkey (SRM ,ARM...)
 - Allocate the logical drive number
 - Select the power module softkey
6. Commission the NCK DMP modules (inputs and outputs)
 - Insert module softkey (DMP-C)
 - Allocate the logical drive number
 - Switch modules into the active state

7. Power-up the NCK
(The following error appears: 300010 "Axis %1 , Drive %2 active without NC axis assignment")
8. Change the axis-specific machine data
 - MD30130[0]: CTRLOUT_TYPE = 1
 - MD30240[0]: ENC_TYPE = 1
9. Power-up the NCK
(Error 300701 "Axis %1, Drive %2 Start-up required")
10. Enter motor types
 - Drive MD softkey
 - Motor/controller softkey
 - Select motor softkey (e.g. 1PH...)
 - Select motor measuring system
 - Save the boot file
11. Power-up the NCK
12. If faults occur at this position, for example 25201,300504,25000 or 300613, then a position measuring system is still active at the interface. Both position measuring systems for the axis should be de-activated.
Position measuring system 1 (DB3x.DBX1.5) = 0 (≐ "parking axis")
Position measuring system 2 (DB3x.DBX1.6) = 0 (≐ "parking axis")
13. Commission "Safety Integrated" as described in Chapter 7 and set MD 36915: SAFE_ENC_TYPE to 1 or 4!

If terminals 663 or AS1/AS2 on the control card are already connected-up, then the supply must be made from the PLC side, as otherwise errors will occur for the crosswise data comparison.

(Also refer to Chapter 10.3.4 "Connecting-up the drives")

10.12 Direction detection when retracting from SE

Description

When SE responds, there is no SGA signal to indicate which SE was exceeded or not reached. In order to only allow retraction from the safe limit position in the permitted direction, it is necessary to develop a retraction logic in the PLC program. A possible solution is outlined below.

Acknowledging and retracting (refer to Chapter 5.6.1)

The axis in which the SE has responded is moved into a range in which the monitoring system no longer responds. This is achieved by first canceling the user enable (the SE monitoring system is then no longer active) or by changing over to another SE (with a longer traversing range).

The error message output when the safe limit position is exceeded must be acknowledged in accordance with the configured stop response.

Conditions for retraction

If SE– responds, traversing motion in the negative (minus) direction must be inhibited; if SE+ responds, traversing motion in the positive (plus) direction must be inhibited. This prevents damage to the mechanical system and simplifies operation at this point.

Development of the retraction logic

The "safe cam" SI function is used for the solution. A detailed description of this function is given in Chapter 5.7. The section below only describes how the function is used.

The retraction logic is based on the following considerations:

1. SI function "safe cams": The SGA signal assigned to the safe cam is only used on the PLC side (it is not necessary to configure the machine data). This meets the needs of the application in question because a fail-safe function is not required and the traversing inhibit can only be initiated through one channel.

The following interface signals are relevant in the axis DB

SN1–	DBX.109.0	SN1+	DBX.109.1
SN2–	DBX.109.2	SN2+	DBX.109.3
SN3–	DBX.109.4	SN3+	DBX.109.4
SN4–	DBX.109.6	SN4+	DBX.109.7

2. Interface signals for the hardware limit switch function

The following interface signals in the axis DB are relevant
(refer to Description of Functions /A3/ "Axis Monitoring, Protective Zones")

Hardware limit switch- DBX12.0

Hardware limit switch+ DBX12.1

If the signal is detected as being set, Alarm 21614 "Hardware limit switch + or -" is output and the axis is immediately braked (this is not necessary based on the configured stop response). Further traversing motion is only permitted in the appropriate retraction direction.

Fig. 10-55 illustrates the inter-relationships at the machine and is used to explain the appropriate configuring.

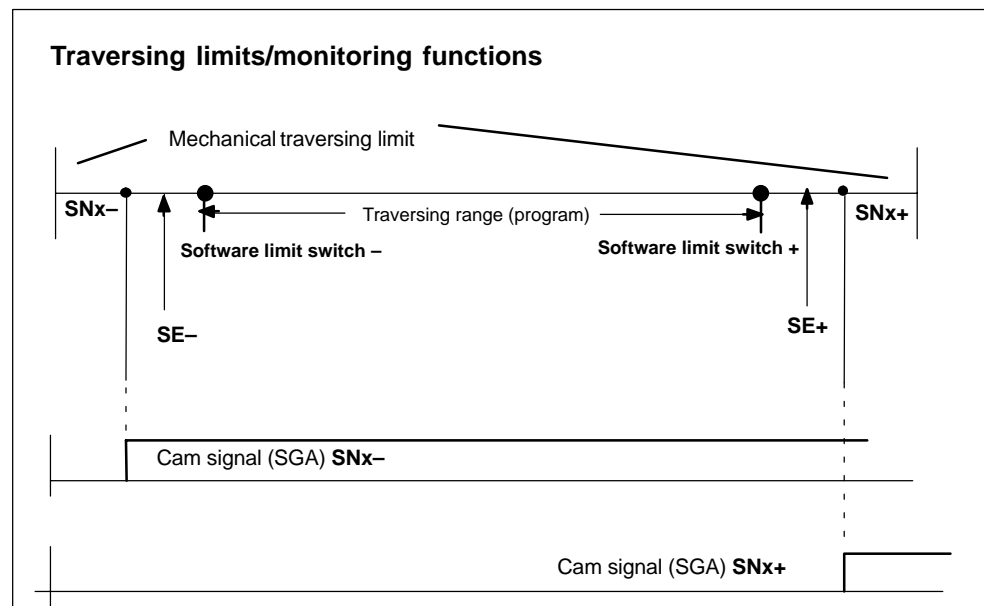

Fig. 10-55 Example of the retraction logic

The minus cam of a cam pair, for example (cams SN1+ – SN4– can all be used), is set up in the machine data at the position immediately in front of the left safe limit position (SE–). It must be ensured that SN– is passed if SE– is passed. This means that the difference should be kept as short as possible (we recommend 0...0.1 mm).

A cam should be set up in the MD at the position directly after the right safe limit position.

The signal characteristics (of the interface signals – SGA) for the two configured cams is shown in the diagram. These two signals can be used to supply information to the hardware limit switch +/- interface signals.

10.12 Direction detection when retracting from SE

Implementation in the PLC

The interface signal for the hardware limit switch– (DBX12.0) should be supplied with the inverted cam signal of SNx– and the interface signal for the hardware limit switch+ (DBX12.1) should be supplied with the cam signal of SN+. It should be noted that the SGA for the cam signal is not available until the drive has been powered–up.

Example (when using the 1st cam pair)

```

U      DB10.DBX108.5          // Drives in the cyclic mode
L      S5T#50ms              // Transition period to avoid
                                // timing problems
SE     T100                  // Timer as input delay
UN     T100                  // while time has still not expired
SPB    NOSN                  // the HW limit switch
                                // signals are not supplied

UN     DB<axis>.DBX109.0     // SN1-
=      DB<axis>.DBX12.0     // Hardware limit switch -

U      DB<axis>.DBX109.1     // SN1+
=      DB<axis>.DBX12.1     // Hardware limit switch +
NOSN: NOP 0

```

This logic can be used to implement the required interlocking function when retracting from SE.

10.13 Replacing a motor or encoder



Warning

After hardware and/or software components have been changed or replaced, it is only permissible to run-up the system and activate the drives when the protective devices are closed. Personnel may not be in the hazardous area.

Depending on the change or replacement, it may be necessary to carry-out a new, partial or complete acceptance test (refer to Chapter 7.2 Acceptance report). Before persons re-enter the hazardous area, the drives should be tested to ensure that they exhibit stable behavior by briefly moving them in the plus and minus directions (+/-).



Warning

After the measuring system has been replaced – regardless of whether it is a direct or an indirect system – the relevant axis must be re-calibrated.

The user can suppress the automated internal actual value check by resetting the "user agreement" – therefore requesting that the axis is re-calibrated with the appropriate user agreement.

References for SINUMERIK 840D

References: /IAD/, Commissioning Manual
/R1/, Reference Point Approach

10.13 Replacing a motor or encoder

Description

The following information essentially refers to replacing a motor encoder.. The limitations that apply as well as the procedures are essentially the same as when replacing a direct measuring system.

When service is required (motor defective or encoder defective), it might be necessary to completely replace the motor or just the motor encoder.

In this case, the motor encoder must be re-calibrated. This influences the behavior of Safety Integrated if the functionality "safe limit positions" or "safe cams" have been activated for the axis in question, i.e. the axis has the status "safely referenced". Depending on which motor measuring system is used, it might be necessary to select a different procedure.

The procedure for replacing a motor with absolute value encoder and to replace a motor with incremental encoder are described in the following text. The end of the Chapter discusses 2-encoder systems.

Limitations/secondary conditions

As mentioned above, the functionality "safe limit positions" or "safe cams" is active for the axis in question.

The user agreement is set for the axis, i.e. the axis has had the status "safely referenced" at least once – the actual position value of the NC and the SI actual values (axis/drive) have been appropriately calibrated.

"Safe limit positions" or "Safe cams" have been able to be used.
A motor or motor encoder has to be replaced under these limitations/conditions.

Replacing a motor with absolute value encoder

In order to set-up the encoder, the offset between the machine zero and the zero of the absolute encoder was determined and saved in the SRAM of the NC module.

The calibrated state is identified by the control using
MD 34210: ENC_REFP_STATE = 2.

The important factor when replacing a motor (also without Safety Integrated) is that a defined position reference can be established with respect to the mechanical parts of the machine. For example, by mounting and removing the motor at a defined mechanical position or appropriately re-calibrating the system after the motor has been replaced.

After the old motor has been removed and the new motor installed, another actual position value is read by the new absolute value encoder (there is no longer a defined reference to the correctly calibrated actual position value).

Therefore the following error profile appears when the control runs-up:

Alarm 27001 Axis <name of the axis> fault in a monitoring channel,
Code **1003**, values: NCK 0, drive 0

The comparison between the saved standstill position and the actual position indicates a larger deviation than that specified in MD 36944:
\$MA_SAFE_REFP_POS_TOL (actual value comparison tolerance (referencing))
or MD 1344: \$MD_SAFE_REFP_POS_TOL

The alarm results in a STOP B followed by a STOP A (safe pulse cancellation) for the axis involved.

The user agreement is also cancelled. This means that the axis loses the status "safely referenced" in connection with the Alarms 27000/300950 axis <name of the axis> not safely referenced.

The actual position value supplied by the new motor encoder has no reference to the mechanical system. This means that the absolute value encoder must be re-aligned and set-up at this point.

Note

A safety acceptance report is generally not required after a motor has been replaced.

Re-calibration procedure

1. Carry-out an NCK reset

10.13 Replacing a motor or encoder

Note

After the NCK reset, the axis can be traversed again. Alarms 27000/300950 "Axis not safely referenced" are still present and indicate that the functions "safe limit positions" and "safe cams" are not active in this state. For example, if the "safe limit positions" are to be used as a substitute for hardware limit switches, then they are not functioning at this time!

2. Move the axis to the reference position after first setting MD 34010 REFP_CAM_DIR_IS_MINUS according to the approach direction. (34010 should be set to 1 if the axis is moved in the negative (minus) direction to the reference position.)
3. MD 34100: Set REFP_SET_POS to the actual value of the reference position.
4. MD 34210: Set ENC_REFP_STATE = 1 to activate the calibration.
5. Select the axis that is to be calibrated on the machine control panel and press the RESET key on the machine control panel.
6. Select the JOG/REF mode, enable the axis feed.
7. The calibration process must be initiated with traversing key + or – according to MD 34010: REFP_CAM_DIR_IS_MINUS and the approach direction to the reference position. (Backlash has been moved through).
8. The axis does not traverse. Instead, the offset between the correct actual value (reference position) and the actual value – supplied by the encoder – is entered in MD 34090: REFP_MOVE_DIST_CORR. The actual value appears in the basic screen and the axis signals "referenced". The value 2 is entered in MD 34210 as result.
Example:
MD 34010=1 (minus) and the reference position was approached in the negative (minus) direction. This means that the "–" key must also be pressed on the machine control panel.
9. When the absolute value encoder has been re-calibrated (MD 34210 from 1 → 2), the axis changes over into the "referenced" state. At this time, the new valid actual position is accepted as the safe actual values (axis and drive).
10. Finally, with the JOG/REF machine mode active, on the MMC the "user agreement" softkey must be pressed and the user agreement for the axis involved must be reset. Alarms 27000/300950 disappear and the functions "safe limit position" and "safe cams" are safely active again.

Replacing a motor with incremental encoder

The same conditions apply as when replacing a motor with absolute value encoder – these are described first.

To calibrate the encoder, a reference point approach has been set up, e.g. with reference point cams. This means that after the zero mark has been passed when leaving the cam, the reference point is approached according to the offsets in 34080 REFP_MOVE_DIST and 34090 REFP_MOVE_DIST_CORR – and the value of the reference point is set in MD 34100: REFP_SET_POS. After the referencing operation, Alarm messages 27000/300950 "Axis not safely referenced" disappear and the functions "safe limit positions" and "safe cams" are safely active.

The important factor when replacing a motor (also without Safety Integrated) is that a defined position reference can be established with respect to the mechanical parts of the machine. This can be achieved by mounting and removing the motor at a defined mechanical position or appropriately re-calibrating the configuration after the motor has been replaced.

After the old motor has been removed and the new motor installed, the following procedure is recommended:

Re-calibration procedure

1. Run-up the control or carry-out an NCK reset
2. If the JOG/REF machine mode is active on the MMC, the "user agreement" softkey must be pressed and the user agreement for the axis involved is withdrawn to avoid
Alarm 27001 Axis <name of the axis> fault in a monitoring channel, Code **1003**, values: NCK 0, drive 0
3. After the system has run-up, the JOG/REF mode is selected and the feed enable for the axis is issued. Carry-out a reference point approach for the axis involved.

10.13 Replacing a motor or encoder

Note

The error at a reference point approach is no more than one revolution of the motor (difference between two zero marks). This offset is usually not critical for the mechanical parts of the machine. If problems arise with the traversing limits because of the type of reference point approach, then for example, set the offset values in MD 34080/34090 to non-critical values.

Alarms 27000/300950 "Axis not safely referenced" are still present and indicate that the functions "safe limit positions" and "safe cams" are not active in this state.

For example, if "safe limit positions" is being used as a substitute for hardware limit switches, then it is important to note that at this time, the safe limit positions are not functional!

After completion of the reference point approach, the axis goes into the "referenced" status. However, because of the zero mark offset between the encoders, the reference position still has to be calibrated, i.e. the position reference with respect to the mechanical system must be re-established. The system is calibrated after measuring the difference – usually in MD 34080 REFP_MOVE_DIST or 34090 REFP_MOVE_DIST_CORR.

4. After the reference point has been re-calibrated, the reference point approach must be re-initiated. The axis changes over into the "referenced" state. At this time, the reference point value is taken over as the safe actual value for the axis and drive.
5. Finally, with the JOG/REF machine mode active, on the MMC the "user agreement" softkey must be pressed and the user agreement for the axis involved must be reset. Alarms 27000/300950 disappear and the functions "safe limit position" and "safe cams" are safely active again.

Comments about 2–encoder systems

Case A

1st measuring system: Incremental motor measuring system

2nd measuring system: Absolute direct measuring system

The 2nd position measuring system (DBX 1.5 = 0, DBX 1.6 =1) is selected via the axis interface as the active measuring system.

In this case, motor replacement is straightforward because the NC reference point position is only supplied with values from the 2nd measuring system (DMS).

Case B

1st measuring system: Absolute motor measuring system

2nd measuring system: Incremental direct measuring system

The 1st position measuring system (DBX1.5 = 1, DBX 1.6 =0) is selected as the active measuring system via the axis interface when the system runs–up. This is for monitoring purposes. A changeover is then made to the 2nd position measuring system (DBX 1.5 = 0, DBX 1.6 =1).

In this case, the motor must be replaced carefully observing the **Description, motor with absolute value encoder**. This is because it is necessary to re–calibrate the absolute value encoder. When re–calibrating the system, we recommend that you permanently select the 1st position measuring system and the axis is only traversed using the motor measuring system.

10.14 Service functionality for axes with two encoder systems

For safety axes with two encoder systems, users can implement specific service functions so that when repair is required for a safety–alarm, the safety axis can still be operated.

Examples of such service cases:

- Moving/traversing the axes in the JOG mode when fault message 27001/Code 3 is present, in order to be able to replace the direct measuring system in this case.
- Gantry synchronization for axes with two encoder systems.

The user can implement these service functions as follows:

- Select the service function (e.g. key–operated switch) using SGEs of the SPL
- The SPL selects the safety functions related to the axis (e.g. SBH/SG etc) for the actual axis involved.
- If safety endstops and safety cams have been configured, then the operator must additionally withdraw the user agreement for the particular axis.
- In this state, although a safety fault is present (27001), the axis can be moved/traversed in the jog mode using the traversing buttons/keys.

The automatic and MDA mode – as well as rapid traverse – should be inhibited with the service function is selected.

10.15 Examples for safely entering gearbox ratios

Task

The gearbox ratio (encoder/load) at a spindle should be safely detected when using a four–stage gearbox.

In this case, a differentiation is made between a 2–encoder system (example 1, refer to Fig. 10-56, "Spindle with 2–encoder system") and a 1–encoder system (example 2, refer to Fig. 10-57, "Spindle with a 1–encoder system").

Example 1: Spindle with a 2–encoder system

The two–channel monitoring function is achieved as follows – the speed detected by the second encoder is compared to the speed of the motor encoder, taking into consideration the gearbox ratio.

The gearbox ratio does not have to be selected in a safety–related fashion and can be implemented through one channel.

Assumptions made for example 1

- The gearbox stage is selected from an NC program using an H function via the PLC user program.
- The second encoder system is connected at the input "direct measuring system" on the 611digital control module.
- The SBH/SG SI function is enabled.
- If the SE or SN safety functions are used for the spindle, then the gearbox stage changeover must also be activated in the NCK channel (request signals E1/E2, refer to Fig. 10-56). This is necessary so that the two channels have the state "axis not safely referenced" as a result of the gearbox stage changeover. The machine data settings for the input assignment, gearbox ratio selection (bits 0, 1, 2) for the NCK are described in Chapter 6.1 "Machine data for SINUMERIK 840D".
- The PLC–SGEs to select the gearbox ratio are described in Chapter 6.4, "Interface signals".
- The example applies to the 1st drive.
- The motor encoder system is parameterized in the drive machine data. The second encoder system is parameterized in the NCK machine data of the control system.

Table 10-4 Overview of the encoder data for 840D

Number	Identifier
36910	\$MA_SAFE_ENC_SEGMENT_NR
36911	\$MA_SAFE_ENC_MODULE_NR
36912	\$MA_SAFE_ENC_INPUT_NR
36915	\$MA_SAFE_ENC_TYPE
36916	\$MA_SAFE_ENC_IS_LINEAR
36917	\$MA_SAFE_ENC_GRID_POINT_DIST
36918	\$MA_SAFE_ENC_RESOL
36920	\$MA_SAFE_ENC_GEAR_PITCH
36921	\$MA_SAFE_ENC_GEAR_DENOM[n]
36922	\$MA_SAFE_ENC_GEAR_NUMERA[n]
36925	\$MA_SAFE_ENC_POLARITY
Note: Data is described in Chapter 6.1, "Machine data for SINUMERIK 840D"	

Table 10-5 Overview of encoder data for 611digital

Number	Identifier
1316	\$MD_SAFE_ENC_CONFIG

10.15 Examples for safely entering gearbox ratios

Table 10-5 Overview of encoder data for 611digital

Number	Identifier
1317	\$MI_SAFE_ENC_GRID_POINT_DIST
1318	\$MI_SAFE_ENC_RESOL
1320	\$MI_SAFE_ENC_GEAR_PITCH
1321	\$MI_SAFE_ENC_GEAR_DENOM[n]
1322	\$MI_SAFE_ENC_GEAR_NUMERA[n]
Note: Data is described in Chapter 6.2, "Machine data for SIMODRIVE 611digital"	

- The tolerance for the actual value comparison of the two encoders is defined in the following machine data:

For 840D: MD 36942: \$MA_SAFE_POS_TOL

For 611digital MD 1342: \$MD_SAFE_POS_TOL

Note

The SGEs/SGAs used in the NCK monitoring channel must be only supplied in the drive monitoring channel from the machinery construction OEM. The reason for this is that the NCK measuring system is directly mounted. This means that SGEs can be supplied through one channel when the gearbox ratio is changed over (no safety risk).

An exception is the use of the SN/SE (refer above).

The gearbox stage selection for Safety Integrated is not part of the crosswise data comparison between the two channels.

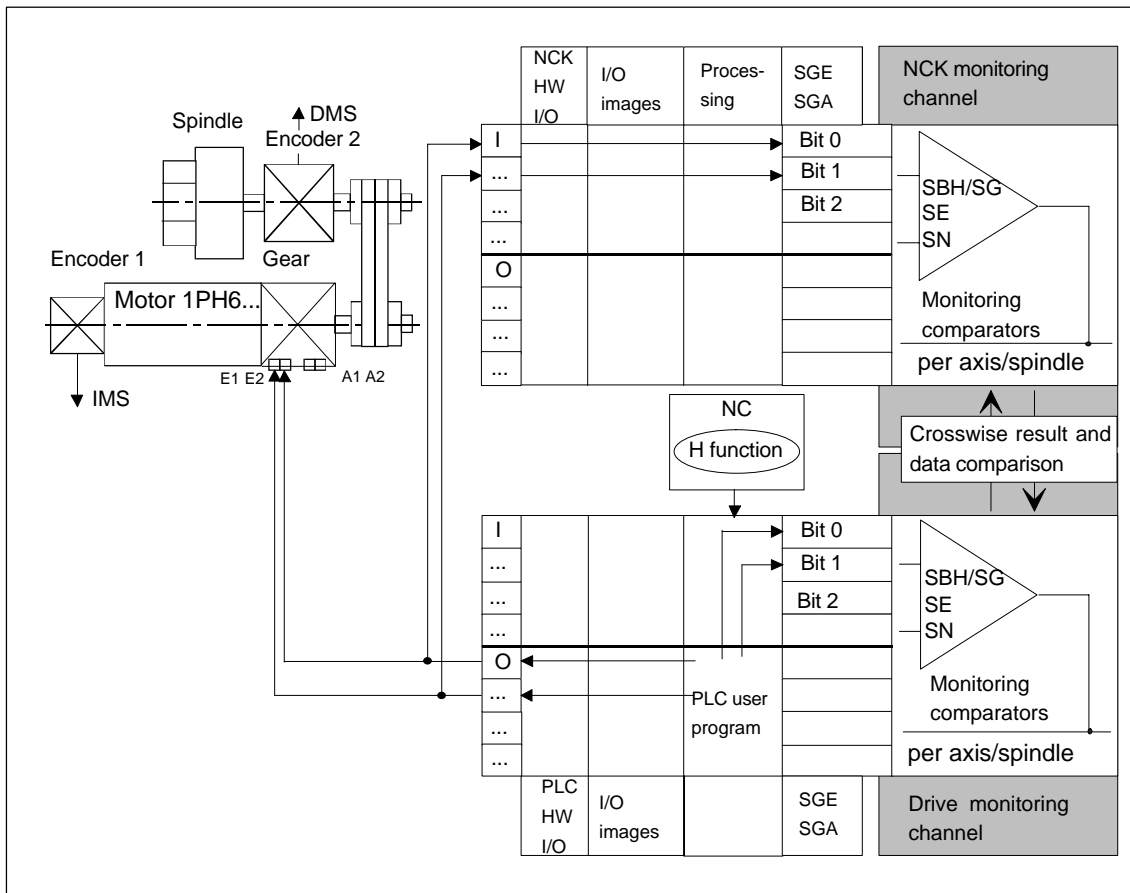

Fig. 10-56 Spindle with a 2-encoder system

Table 10-6 Assignment, gearbox stage/ratio selection

Selection and feedback of the gearbox stage					Assignment, ratio selection for NCK and PLC/drive			Spindle motor/load
Gearbox stage	E1	E2	A1	A2	SGE gearbox ratio selection			
					Bit 2	Bit 1	Bit 0	
1	0	0	0	0	0	0	0	4 : 1
2	0	1	0	1	0	0	1	2.5 : 1
3	1	0	1	0	0	1	0	1.6 : 1
4	1	1	1	1	0	1	1	1 : 1

10.15 Examples for safely entering gearbox ratios

Table 10-7 Entering the gearbox stage ratio in the machine data

	Stage	840D		611digital	
		MD No.	Value	MD No.	Value
Denominator of the gearbox ratio Encoder/load	1	36921[0]	1	1321.0	250
	2	36921[1]	1	1321.1	400
	3	36921[2]	1	1321.2	625
	4	36921[3]	1	1321.3	1000
Numerator of the gearbox ratio Encoder/load	1	36922[0]	1	1322.0	1000
	2	36922[1]	1	1322.1	1000
	3	36922[2]	1	1322.2	1000
	4	36922[3]	1	1322.3	1000

Note

With the circuit described above (Fig.), the request signals E1/E2 to change over the gearbox stage for the PLC and drive are taken from the gearbox signal.

For SE/SN, the gearbox stage changeover must also take place on the NCK side.

When the motor moves in the de-coupled state, only the motor measuring system pulses can be counted, but not those from the direct measuring system. This is the reason that an offset can occur between the SI actual values. As this cannot be avoided, gear stage changeover without errors is only possible under the following conditions:

1. The gearbox stage is selected at standstill. This means that the offset in time does not result in any offset between the two SI actual values.
2. The gear stage is selected when the motor is moving (e.g. oscillating), i.e. the motor is moving although this cannot be detected at the direct measuring system. In this case, the following measures are possible to avoid errors
 - a) MD 36942 and MD 1342 SAFE_POS_TOL should be parameterized so that they are appropriately high and after the gearbox stage has been selected, the spindle must be re-synchronized (<axis DB>.DBX 16.6 or DBX 16.7 : Active measuring system) (if this isn't carried-out anyway) in order to align the SI actual values again, or
 - b) the actual value synchronization function should be used

Example 2: Spindle with a 1-encoder system**Assumptions made for example 2**

- The gearbox stage is selected from an NC program using an H function via the PLC user program.
- The gearbox stage ratio is selected through two channels.

10.15 Examples for safely entering gearbox ratios

- The encoder system is connected at the "direct measuring system" input on the 611digital control module.
- The machine data for the input assignment ratio selection (bits 0, 1, 2) for the NCK are described in Chapter 6.1, "Machine data for SINUMERIK 840D").
- The PLC–SGEs to select the ratio are described in Chapter 4.3, "Interface signals".
- The motor encoder system is parameterized in precisely the same way in the drive machine data and in the NCK machine data of the control.
- The example applies to the 1st drive.
- The SBH/SG SI function is enabled.

Table 10-8 Overview of the encoder data for 840D

Number	Identifier
36910	\$MA_SAFE_ENC_SEGMENT_NR
36911	\$MA_SAFE_ENC_MODULE_NR
36912	\$MA_SAFE_ENC_INPUT_NR
36915	\$MA_SAFE_ENC_TYPE
36916	\$MA_SAFE_ENC_IS_LINEAR
36917	\$MA_SAFE_ENC_GRID_POINT_DIST
36918	\$MA_SAFE_ENC_RESOL
36920	\$MA_SAFE_ENC_GEAR_PITCH
36921	\$MA_SAFE_ENC_GEAR_DENOM[n]
36922	\$MA_SAFE_ENC_GEAR_NUMERA[n]
36925	\$MA_SAFE_ENC_POLARITY
Note: Data is described in Chapter 6.1, "Machine data for SINUMERIK 840D"	

Table 10-9 Overview of encoder data for 611digital

Number	Identifier
1316	\$MD_SAFE_ENC_CONFIG
1317	\$MI_SAFE_ENC_GRID_POINT_DIST
1318	\$MI_SAFE_ENC_RESOL
1320	\$MI_SAFE_ENC_GEAR_PITCH
1321	\$MI_SAFE_ENC_GEAR_DENOM[n]
1322	\$MI_SAFE_ENC_GEAR_NUMERA[n]
Note: Data is described in Chapter 6.2, "Machine data for SIMODRIVE 611digital"	

10.15 Examples for safely entering gearbox ratios

- Defining the SGEs/SGAs in the NCK monitoring channel
 - for 840D

Logical slot for the terminal block:	5
Slot number of the sub-module for SGEs:	3
I/O number for the signal, ratio selection, bit 0:	1
I/O number for the signal, ratio selection, bit 1:	2

Note

The SGEs/SGAs used in the NCK monitoring channel must also be supplied by the machinery construction OEM in the drive monitoring channel.

A parameter set change using SGEs must be coupled with a parameter set change on the NC side.

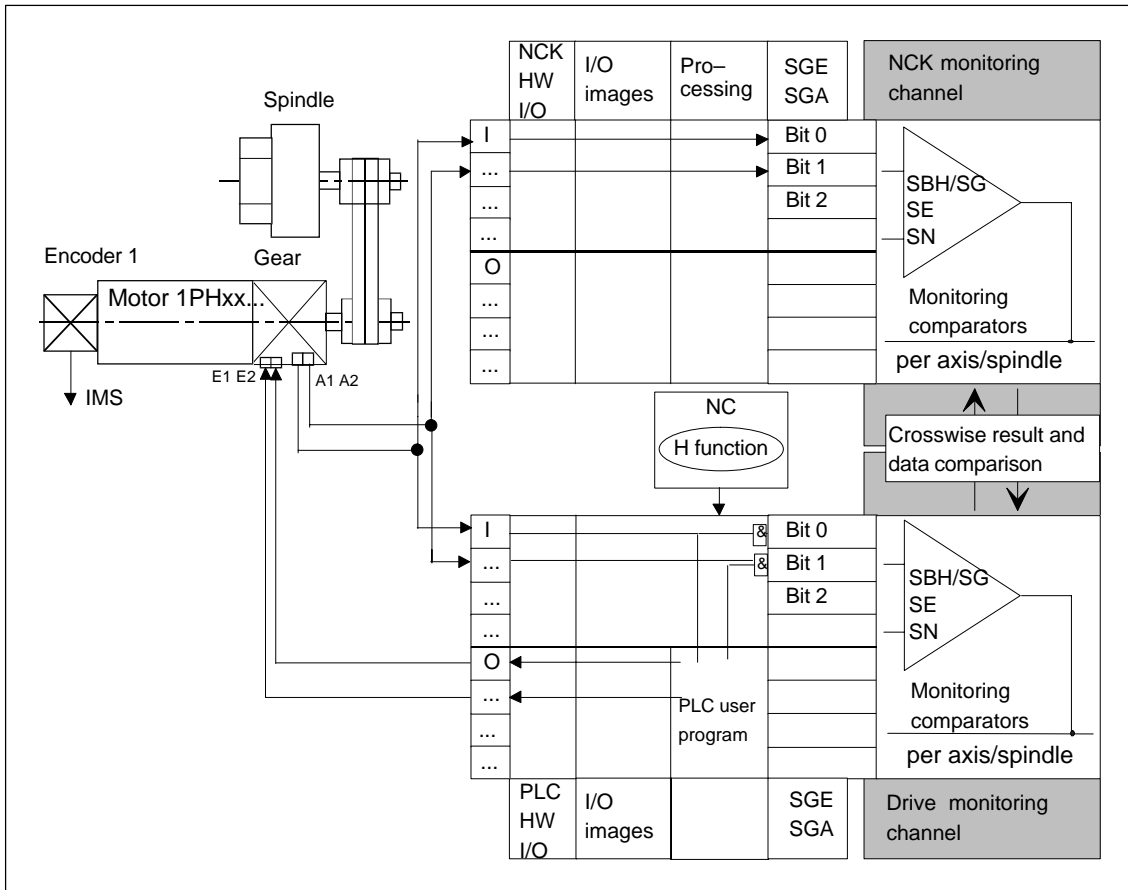

Fig. 10-57 Spindle with a 1-encoder system

Note

Using the circuit above (Fig. 10-57) it is guaranteed that the request signals E1/E2 to changeover the gearbox stage for the NCK/PLC and drive are simultaneously initiated. As a result of the different processing times of the two channels (generally, the NCK detects the signal change earlier than the PLC due to the PLC cycle time), then an offset (in time) does occur for the internal gearbox stage selection. As this cannot be avoided, gear stage changeover without errors is only possible under the following conditions:

1. The gearbox stage is selected at standstill. This means that the offset in time does not result in an offset between the two SI actual values
2. The gear stage is selected when the motor is moving (e.g. oscillating), i.e. the time delay also cause an offset of the SI values. In this particular case, the following measures are possible:
MD 36942/and MD 1342 SAFE_POS_TOL should be parameterized to be appropriately high and after the gearbox stage has been changed-over, the spindle is re-synchronized (<axis-DB>.DBX 16.6) (if this isn't already carried-out). This then re-aligns the SI actual values.

Table 10-10 Assignment, gearbox stage/ratio selection

Selection and feedback of the gearbox stage					Assignment, ratio selection for NCK and PLC/drive			Spindle motor/load
Gearbox stage	E1	E2	A1	A2	SGE gearbox ratio selection			
					Bit 2	Bit 1	Bit 0	
1	0	0	0	0	0	0	0	4 : 1
2	0	1	0	1	0	0	1	2.5 : 1
3	1	0	1	0	0	1	0	1.6 : 1
4	1	1	1	1	0	1	1	1 : 1

Input assignment for selecting gearbox ratios

Table 10-11 Supplying the machine data for the SGEs for 840D

Signal SGE/SGA	Name	Assignment	
		MD No.	Value
SGE	Ratio selection, bit 0	36974[0]	01 05 03 01
SGE	Ratio selection, bit 1	36974[1]	01 05 03 02

10.16 Example for spindles with 2 encoders and drive with slip

Table 10-12 Entering the gearbox stage ratio in the machine data

	Stage	840D		611digital	
		MD No.	Value	MD No.	Value
Denominator of the gearbox ratio Encoder/load	1	36921[0]	10	1321.0	10
	2	36921[1]	10	1321.1	10
	3	36921[2]	10	1321.2	10
	4	36921[3]	10	1321.3	10
Numerator of the gearbox ratio Encoder/load	1	36922[0]	40	1322.0	40
	2	36922[1]	25	1322.1	25
	3	36922[2]	16	1322.2	16
	4	36922[3]	10	1322.3	10

10.16 Example for spindles with 2 encoders and drive with slip

General information

When subject to crosswise data comparison the actual values between the NCK and drive must lie within an actual value tolerance specified in the MD. If the tolerance value is violated, STOP F is output.

Note

It is not possible to activate the safe SE and SN functions for an axis/spindle where slip can occur between the motor and the load.

System behavior

For the configuration shown in Fig. 10-58 "Problem for drives subject to slip", the following behavior is manifested:

The SI actual values for the drive and the NCK are each provided from a separate encoder. Due to the slip produced by the belt drive, the actual value between the two encoders drifts apart. This means that the actual value tolerance is violated with the relevant stop response.

10.1 Example for spindles with 2 encoders and drive with slip

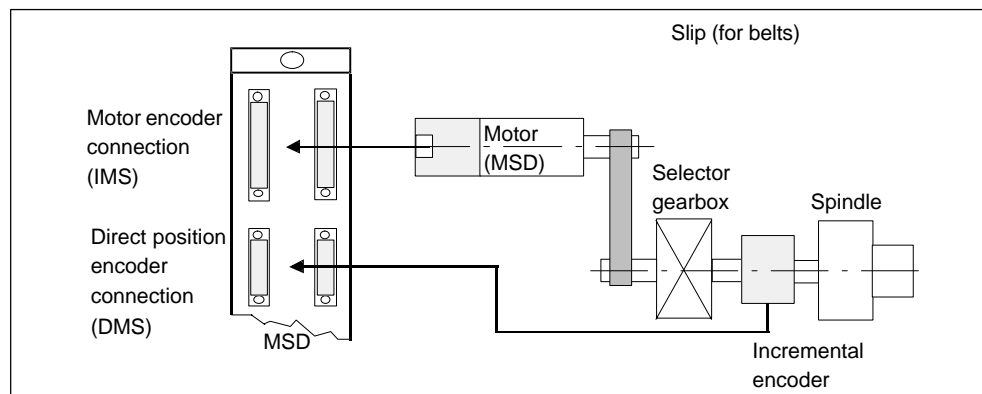

Fig. 10-58 Motor for a drive subject to slip

Configuring options

In the configuration shown in Fig. 10-59, the SI actual values for the NCK and drive are taken from one encoder (this is the motor encoder).

As the actual value of the motor encoder is used for both monitoring channels, the slip is ignored in this particular configuration (this is the same behavior as for a 1-encoder system).

If there is no free actual value input, an additional module must be used.

An actual value input on another drive module must be used for spindle positioning. This drive may not be an SI axis.

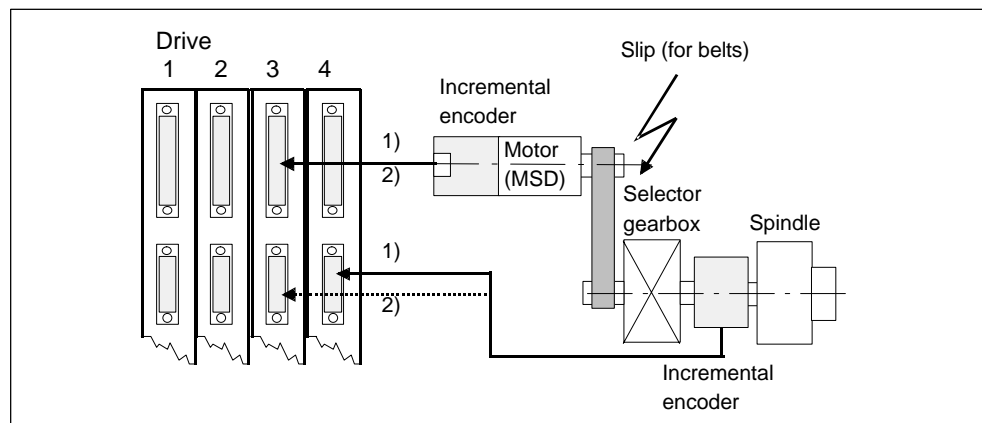

Fig. 10-59 Configuration for a spindle with a drive subject to slip and 2 encoders

10.16 Example for spindles with 2 encoders and drive with slip

Machine data for 840D/611digital

The MD values refer to 2 cases (refer to Fig. 10-59):

Slip may exist between load and motor (belts) and is ignored.

Slip may not exist between the load and motor (toothed belts)

Table 10-13 Overview of the machine data

MD No.	MD name	MD value	
		for 1)	for 2)
30110	CTRLOUT_MODULE_NR[0]	3	3
30200	NUM_ENCS	1	1
30220	ENC_MODULE_NR[0]	4	3
30230	ENC_INPUT_NR[0]	2	2
32110	ENC_FEEDBACK_POL[0]	-1	-1
36912	SAFE_ENC_INPUT_NR	1	2
36925	SAFE_ENC_POLARITY	1	-1
1316	SAFE_ENC_CONFIG	0	4

10.17 Example for combining SI with ESR

General

If the ESR functionality (refer to the Description of Functions, Special Functions) is to be used on a machine together with Safety Integrated, then frequently, problems are encountered with the responses when a fault or error develops. The shutdown responses from Safety Integrated (safe state, pulse cancellation) prevent the required retraction motion or delayed stopping of the axes. This example shows a possible parameter assignment for Safety Integrated functionality that still guarantees optimum machine protection in the automatic mode.

Required configuration

ESR:

If a fault or error situation is detected in the automatic mode, the X axis should make a retraction movement – the other axes should continue to move for a short time and then should be braked along the parameterized braking ramp of the interpolator. If communications to the drive are faulted, then the X axis should retract – also in the automatic mode. ESR should not become active if personnel are in the hazardous zone of the machine.

This is the reason that ESR should be parameterized as follows at the machine (the following doesn't provide a complete parameterization of the ESR function, only that part required to obtain an understanding):

Parameterization of the channel-specific ESR machine data (NC controlled retraction)

MD 21380 \$MC_ESR_DELAY_TIME1=0.1; Continue to move for a short time
MD 21381 \$MC_ESR_DELAY_TIME2=3.0; Time for the braking ramp

Parameterizing the axis-specific ESR machine data (NC controlled retraction)

MD 37500 \$MA_ESR_REACTION[AX1]=21; Retraction motion of the X axis
MD 37500 \$MA_ESR_REACTION[AX2]=22; Stopping the Y axis

Parameterizing the drive-specific machine data (retraction that is executed independently in the drive)

MD 1638 \$MD_RETRACT_TIME[DR1]=200
Retraction time, function executed independently in the drive, X axis
MD 1639 \$MD_RETRACT_SPEED[DR1]=400000
Retraction speed, X axis
MD 1637 \$MD_GEN_STOP_DELAY[DR2]=200
Stopping time, function executed independently in the drive, Y axis

10.17 Example for combining SI with ESR

Safety Integrated

The safely-reduced speed should be monitored for the X and Y axes as soon as anybody has entered or is in the hazardous zone of the machine. This is detected if the protective door is opened or closed. Further, the safe limit switches are activated for Y axis and SPL is also used. SG2 is active in the automatic mode (with an extremely high speed limit); SG1 is active when the protective door is open.

Hazardous situations

The following hazardous situations can occur in the automatic mode where Safety Integrated can prevent the required ESR:

- The protective door switch fails in one channel. This is the reason that as a result of the crosswise data comparison of the SPL, a Stop D is initiated after 1 s.
- The protective door switch fails in one channel. This is the reason that as a result of the crosswise data comparison of the NCK and drive, a Stop F with subsequent Stop B/A is initiated at the earliest after the time specified in MD \$MA_SAFE_MODE_SWITCH_TIME.
- Any other failure results in a crosswise data comparison error for the NCK and drive and therefore, in turn, to a Stop F/B/A.
- If communications to the drive fail (drive bus failure), then the pulses are immediately cancelled. This therefore prevents ESR being autonomously executed in the drive (as drive-based function).

Eliminating the hazardous situations

These hazardous situations can be resolved as follows:

1. **Stop E is activated as response to the speed being exceeded in SG2 and for SPL crosswise data comparison errors:**

MD 10097 \$MN_SAFE_SPL_STOP_MODE = 4

Default value 3. For errors in the crosswise data comparison of the SPL (Alarm 27090), with the value 4, a Stop E is initiated instead of a Stop D. At the same time, bit DB18.DBX36.1 must be set in the PLC:

SET

= DB18.DBX36.1 (enable Stop E)

MD 36901 \$MA_SAFE_FUNCTION_ENABLE[AX1]=51;

X axis: SG/SBH + external Stop E

MD 36901 \$MA_SAFE_FUNCTION_ENABLE[AX2]=53;

Y axis: SG/SBH + SE + external Stop E

Note:

All axes with \$MA_SAFE_FUNCTION_ENABLE not equal to 0 must have enabled the external Stop E, if \$MN_SAFE_SPL_STOP_MODE = 4 was parameterized.

MD 36961 \$MA_SAFE_VELO_STOP_MODE[AX1]=5

\$MA_SAFE_VELO_STOP_REACTION

MD 36961 \$MA_SAFE_VELO_STOP_MODE [AX2]=5;
becomes effective for axes X and Y

MD 36963 \$MA_SAFE_VELO_STOP_REACTION [1,AX1]=3;
Stop D for SG1, axis X

MD 36963 \$MA_SAFE_VELO_STOP_REACTION [2,AX1]=14;
Stop E for SG2, axis X, pulses are not cancelled when the bus fails

MD 36963 \$MA_SAFE_VELO_STOP_REACTION [1,AX2]=3;
Stop D for SG1, axis Y

MD 36963 \$MA_SAFE_VELO_STOP_REACTION [2,AX2]=14;
Stop E for SG2 axis Y, pulses are not cancelled when the bus fails

2. Parameterizing a Stop E:

MD 36954 \$MA_SAFE_STOP_SWITCH_TIME_E[AX1] = 3.5;
3.5 s because ESR was parameterized to be 3.1 s

MD 36954 \$MA_SAFE_STOP_SWITCH_TIME_E[AX2] = 3.5;
3.5 s because ESR was parameterized to be 3.1 s

Note:

The safe operating stop is activated after this time expires.
This is the reason that this transition time for the Stop E must correspond to the ESR times (\$MC_ESR_DELAY_TIME1 + \$MC_ESR_DELAY_TIME2). If this time is selected to be too short, then the retraction motion will not be correctly executed and depending on the safe functions, hard stops will be initiated (Alarm 27024 Stop A/B).

3. Delaying stops following a Stop F:

MD 36955 \$MA_SAFE_STOP_SWITCH_TIME_F[AX1] = 3.5;
3.5 s because ESR was parameterized to be 3.1 s

MD 36955 \$MA_SAFE_STOP_SWITCH_TIME_F[AX2] = 3.5;
3.5 s because ESR was parameterized to be 3.1 s

An ESR can be executed in this time. This is the reason that here it makes sense to use the same time as in \$MA_SAFE_STOP_SWITCH_TIME_E.

4. Delaying pulse cancellation when the drive bus fails:

MD 10089 \$MN_SAFE_PULSE_DIS_TIME_BUS_FAIL[AX1] = 0.5;
0.5 s because ESR was parameterized to be 0.2 s

An ESR can be autonomously executed in the drive (drive-based function) in this time. This time should therefore be adapted to the parameterization of the drive MD \$MD_RETRACT_TIME (in this particular example, 200 ms).

In this example, the system does not wait for this time to expire in the following specific cases:

10.17 Example for combining SI with ESR

- Active SBH
- When an external Stop A is selected
- Active SG1: For SG1, \$MA_SAFE_VELO_STOP_REACTION is parameterized so that when the bus fails, the pulses should be immediately cancelled.

5. Input assignment of the SGE "de-select external Stop E"

```
MD 36977 $MA_SAFE_EXT_STOP_INPUT[3,AX1]=04010109
```

```
Assignment to the SPL: OUTSI[09]
```

```
MD 36977 $MA_SAFE_EXT_STOP_INPUT[3,AX2]=04010109
```

```
Assignment to the SPL: OUTSI[09]
```

DB axis DBX32.5	De-select the external Stop E from the PLC:
U DB18.DBX63.0	(corresponds to OUTSIP[09])
= DB31.DBX32.5	(ext. Stop E axis X)
= DB32.DBX32.5	(ext. Stop E axis Y)

DB axis DBX111.7 includes the checkback signal "Stop E active"

6. Delay time for the SG/SBH changeover:

```
MD 36951 $MA_SAFE_VELO_SWITCH_DELAY[AX1]=4.1 s
```

```
MD 36951 $MA_SAFE_VELO_SWITCH_DELAY[AX2]=4.1 s
```

A value (1s + retraction time) must be entered, for all axes, in MD 36951 (delay time SG and SBH changeover). After 1 s, the defective door switch is detected with Alarm 27090, crosswise data comparison and Stop E is initiated. Depending on the selected SG stage, retraction motion is executed. If this time is significantly shorter than the required retraction time, then the retraction – after this time has expired – is only carried-out at the reduced speed SG1.

7. Initiating ESR:

a) ESR must be enabled in the machining program:

```
$AA_ESR_ENABLE[X] = 1 ; enables ESR for X axis
```

```
LFPOS ;
```

```
POLF[X] = IC(25) ; retraction distance, axis X
```

```
POLFMASK(X) ; Axis X is declared as retraction axis
```

b) ESR must be triggered in synchronous actions (e.g. in SAFE.SPF):

An X axis retraction is initiated if at least one axis detects Stop E:

```
IDS = 250 WHENEVER ($AC_MARKER[20] == 1) AND ($A_STOPESI<>0) DO
$AC_ESR_TRIGGER=TRUE
```

Retraction is automatically initiated if Safety Integrated has detected a problem associated with the actual value sensing (Alarm 27001 with Codes 3 or 44 to 57 has occurred), or a Stop F is present that will result in a subsequent Stop B/A:

```
ID = 251 WHENEVER ($AC_MARKER[20] == 1) AND ($A_XFAULTSI <> 0)
DO $AC_ESR_TRIGGER=TRUE
```

Marker 20 is only used to interlock the retraction, e.g. when testing the external Stop E.

It is possible to respond to fault/error states by using the axis-specific system variables \$VA_STOPSI[axis name] and \$VA_XFAULTSI[axis name].

8. Hardware prerequisites

The pulse enable (terminal 663) must be controlled from an onboard output (MD 36986 \$MA_SAFE_PULS_ENABLE_OUTPUT = 1 or 2 or 3 or 4), as otherwise the pulse cancellation delay time is not effective when the drive fails.

Appendix

A

A.1 Customer Support

The Centre of Competence Service (CoCS) – Sinumerik Safety Integrated® offers users a wide range of services.

Contact addresses

Hotline: Tel.: +49 (0)180–5050–222
 Fax: +49 (0)180–5050–223
 E-mail: <mailto:ad.support@siemens.com>
 Enquiry with subject 840D Safety Integrated

Contact: Tel.: +49 (0)9131 98 4386
 Fax: +49 (0)9131 98 1359

Table A-1 Range of services for machinery construction OEMs and end customers

Portfolio	Description of the services available
Concept development	The safety functions are adapted to the machine based on the hazard analysis and the customer's operating philosophy. This includes e.g.: <ul style="list-style-type: none">• Planned operating modes• Safety functions when the protective doors are closed• Safety functions when the protective doors are open• Emergency stop concept• A study of the safety-related external signals and elements
Standard engineering	Based on the concept developed, the standard functions <ul style="list-style-type: none">• Safe standstill (SH), safe operating stop (SBH)• Safely-reduced speed (SG)• Safe software limit switch (SE), safe software cam (SN) are integrated into the circuit diagram of the machine. External safety elements (e.g. door interlocking, Emergency Stop button, ...) are either configured conventionally or logically combined using the "safe programmable logic" (SPL) function.
SPL configuration	Based on the standard configuration, the following objects are created: <ul style="list-style-type: none">• Function diagram• Logic program for the PLC area• Logic program for the NC area• Data blocks required (e.g. DB 18) These objects are incorporated/linked into the complete system.

A.1 Customer Support

Table A-1 Range of services for machinery construction OEMs and end customers

Portfolio	Description of the services available
Start-up (commissioning)	The safety functions are commissioned based on the configuration that has been created. The customer provides the machine so that the drives can be traversed and the control cabinet is wired according to the configuration.
Acceptance report	<p>Based on the submitted configuration documentation and commissioning, an acceptance report for the safety functions is drawn-up. This includes:</p> <ul style="list-style-type: none"> • Description of the machine (name, type, ...) • Description of the safety and operator concept • Description of the axis-specific safety functions • All of the safety functions are tested including the SPL logic • The test results are recorded <p>The customer receives the acceptance report as hard copy and on an electronic data medium.</p>
Approval procedure	Support with the handling and line of argument for the approval procedure by certified bodies (e.g. the appropriate regulatory bodies/institutes for safety and health) or large end customers.
Workshop	<p>Workshops are held on the subject of machine safety adapted to customer-specific requirements; if required, these workshops can be held at the customer's site. Possible contents:</p> <ul style="list-style-type: none"> • Machinery Directive, Standards in general • C Standards (machine-specific) • Hazard analysis, risk analysis • Control categories (acc. to EN 954-1) • SINUMERIK Safety Integrated[®] – function and system description • Configuration, machine data • Start-up (commissioning) • Acceptance report
Hotline	An expert for "SINUMERIK Safety Integrated [®] " can be reached at the Hotline number should series errors or problems occur during installation and commissioning (start-up).
On-site service (local)	Experts analyze problems that are encountered on-site. The causes are eliminated or counter-measures are drawn-up and implemented where necessary.

A.2 Fault analysis tables

Based on the appropriate Directives and Standards, a detailed fault analysis is carried-out using SINUMERIK Safety Integrated[®]. The subsequently listed brief summary lists the various disturbances and system faults controlled by SINUMERIK Safety Integrated with an extremely low residual risk; whereby the basis was disturbances that are already known.

Table A-2 Fault analysis in the setting-up mode

Assumed fault	Fault causes	Fault control	MDIR, Appendix 1)	Comments
Spindle speed too high	Defect in the drive or control system, encoder fault in 2-encoder operation, operator error etc.	Safe limitation of speed or axis velocity with SG; configurable stop functions according to Cat. 2	Chap. 1.2.4 Chap. 1.2.7 Chap. 1.3.6	According to currently applicable standards (TC143), the SG function – depending on the technology – is only permissible in combination with agreement, jog mode, start button and Emergency Stop
Axis speed too high				According to currently applicable standards (TC143), the SG function – depending on the technology – is only permissible in combination with jog mode, start button and Emergency Stop
Axis or spindle has inadmissibly moved away from standstill position	Defect in the drive or control system, operator error etc.	Safe standstill monitoring for position control with SBH; configurable stop functions acc. to Cat. 0/1 (acc. to 60204)	Chap. 1.2.6 Chap. 1.2.7 Chap. 1.3.6 Chap. 1.4.2 Chap. 1.4.3	Low-wear safe disconnection of the energy feed to the drive, This function does not replace the main machine breaker/switch regarding electrical isolation
		Safe standstill with SH Stop function Cat. 0		
Axes have inadmissibly exited operating range	Defect in the drive or control system, operator error, etc.	"Safe software limit switches" SE; configurable stop functions according to Cat. 2 (acc. to EN 60204)	Chap. 1.2.4 Chap. 1.2.7 Chap. 1.3.7 Chap. 1.3.8	Essentially used for machinery protection. It can also be used to restrict working zones in conjunction with personnel protection.

A.2 Fault analysis tables

Table A-2 Fault analysis in the setting-up mode

Assumed fault	Fault causes	Fault control	MDIR, Appendix 1)	Comments
Response of machine control to incorrect position signal	Defect in the control, operator error, etc.	"Safe software cams" SN; safe signal and position data output	Chap. 1.2.4 Chap. 1.2.7 Chap. 1.3.8 Chap. 1.4.2 Chap. 1.4.3	Wear-free "safe software cams" (SN) used to safely detect the position of axes, can be used to demarcate physical areas
Error relating to the input/output of process data	Defective cable, incorrect information, or similar	Two-channel input/output of safety-related signals (SGE/SGA), crosswise data comparison; initiation of stop functions according to Cat. 1 (acc. to EN 60204)	Chap. 1.2.5 Chap. 1.3.8 Chap. 1.4.2 Chap. 1.4.3	External two-channel inputs or further processing required if function is intended to protect operating personnel

1) Refer to: Attachment, References, General /1/

Table A-3 Error analysis in the test mode

Assumed fault	Fault causes	Fault control	MDIR, Appendix 1)	Comments
Spindle speed too high	Defect in the drive or control system, encoder fault for 2-encoder operation, operator error, part program error,	Safe limitation of speed or axis velocity with SG; configurable stop functions according to Cat. 2	Chap. 1.2.4 Chap. 1.2.7 Chap. 1.3.6	According to currently applicable standards (TC143), the SG function – depending on the technology – is only permissible in combination with agreement, jog mode, start button and Emergency Stop
Axis speed too high	or similar			According to currently applicable standards (TC143), the function – depending on the technology – is only permissible in combination with jog mode, start button and Emergency Stop

Table A-3 Error analysis in the test mode, continued

Assumed fault	Fault causes	Fault control	MDIR, Appendix 1)	Comments
Axis or spindle has inadmissibly moved away from standstill position	Defect in the drive or control system, operator error, part program error, or similar	Safe standstill monitoring for position control with SBH; configurable stop functions acc. to Cat. 0/1	Chap. 1.2.6 Chap. 1.2.7 Chap. 1.3.6 Chap. 1.4.2 Chap. 1.4.3	Wear-free safe disconnection of energy feed to the drive to allow manual intervention in danger zone; function does not replace the main machine breaker regarding electrical isolation
		Safe standstill with SH Stop function Cat. 0		
Axes have inadmissibly exited operating range	Defect in the drive or control system, operator error, part program error, or similar	"Safe software limit switches" SE; configurable stop functions according to Cat. 2	Chap. 1.2.4 Chap. 1.2.7 Chap. 1.3.7 Chap. 1.3.8	Wear-free safe limit switch, essentially used for machinery protection. It can also be used to restrict working zones in conjunction with personnel protection.
Response of machine control to incorrect position signal	Defect in the control, operator error, part program error, or similar	"Safe software cams" SN; safe signal and position data output	Chap. 1.2.4 Chap. 1.2.7 Chap. 1.3.8 Chap. 1.4.2 Chap. 1.4.3	Wear-free "safe software cams" used to safely detect the position of axes, can be used to demarcate physical areas
Error relating to the input/output of process data	Defective cable, incorrect information, or similar	Two-channel input/output of safety-related signals (SGE/SGA), crosswise data comparison, initiation of stop functions according to Cat. 1	Chap. 1.2.5 Chap. 1.3.8 Chap. 1.4.2 Chap. 1.4.3	External two-channel inputs or further processing required if function is intended to protect operating personnel

1) Refer to: Attachment, References, General /1/

A.2 Fault analysis tables

Table A-4 Fault analysis in the automatic mode

Assumed fault	Fault causes	Fault control	MDIR, Appendix 1)	Comments
Spindle or axis speed/velocity too high	Defect in the drive or control system, Encoder fault in 2–encoder operation, operator error, part program error, or similar	Safe limitation of speed or axis velocity with SG; configurable stop functions according to Cat. 2	Chap. 1.2.4 Chap. 1.2.7 Chap. 1.3.6	According to the status (TC143), the SG function is only permissible with protective safety devices/guards (e.g. protective doors)
Axis or spindle has inadmissibly moved away from standstill position	Defect in the drive or control system, operator error, part program error, or similar	Safe standstill monitoring for position control with SBH; configurable stop functions Cat. 0/1	Chap. 1.2.6 Chap. 1.2.7 Chap. 1.3.6 Chap. 1.4.2 Chap. 1.4.3	Low–wear safe disconnection of the energy feed to the motor to allow manual interventions in the hazardous zone (safe location), This function does not replace the main machine breaker/switch regarding electrical isolation
		Safe standstill with SH Stop function acc. to Cat. 0		
Axes have inadmissibly exited operating range	Defect in the drive or control system, operator error, part program error, or similar	"Safe software limit switches" SE; configurable stop functions according to Cat. 2	Chap. 1.2.4 Chap. 1.2.7 Chap. 1.3.7 Chap. 1.3.8	Wear–free safe limit switch, essentially used for machinery protection. It can also be used to restrict working zones in conjunction with personnel protection.
Response of machine control to incorrect position signal	Defect in the control, operator error, part program error, or similar	"Safe software cams" SN safe signal and position data output	Chap. 1.2.4 Chap. 1.2.7 Chap. 1.3.8 Chap. 1.4.2 Chap. 1.4.3	Wear–free safe software cams for safety–related detection of axis positions, can be used to demarcate physical areas
Error relating to the input/output of process data	Defective cable, incorrect information, or similar	Two–channel input/output of safety–related signals (SGE/SGA), crosswise data comparison, initiation of stop functions according to Cat. 1	Chap. 1.2.5 Chap. 1.3.8 Chap. 1.4.2 Chap. 1.4.3	External two–channel inputs or further processing required if function is intended to protect operating personnel

1) Refer to: Attachment, References, General /1/

Table A-5 General fault analysis

Assumed fault	Fault causes	Fault control	MDIR, Appendix 1)	Comments
Error has not been detected because function is not active	Defect in the drive or control system, or similar	Time-controlled request or automatic forced-checking procedure and crosswise data comparison, initiation of stop functions according to Cat. 0	Chap. 1.2.7	Forced-checking procedure must be supported by the user depending on the process
Incorrect safety machine data (MD)	Incorrect information, operator error, or similar	Visual check with Accept softkeys, crosswise data comparison, checksum, initiation of stop functions according to Cat. 0/1	Chap. 1.2.7	Must be confirmed using acceptance test during start-up
Incorrect absolute position of axis or spindle	Incorrect information, axis mechanically influenced, or similar	User agreement after referencing or after power-up	Chap. 1.2.7 Chap. 1.3.8	The assignment to machine zero must be carried-out during start-up

1) Refer to: Attachment, References, General /1/

Fault control enables easy and cost-effective implementation of the requirements of Machinery Directive 98/37EC (MDIR column, Appendix 1).

Topics and Chapter headings of MDIR, Appendix 1

- 1.2.4¹⁾ Stopping, normal stopping and stopping in an emergency
- 1.2.5¹⁾ Mode selector switches
- 1.2.6¹⁾ Power supply fault
- 1.2.7¹⁾ Control circuit fault
- 1.3.6¹⁾ Risks relating to variations in tool speeds
- 1.3.7¹⁾ Preventing risks relating to moving parts
- 1.3.8¹⁾ Selecting protective equipment against risks relating to moving parts
- 1.4.2¹⁾ Special requirements placed on isolating protective equipment
- 1.4.3¹⁾ Special requirements placed on non-isolating protective equipment

1) Refer to: Attachment, References, General /1/

A.3 References

/ASI/

Low-Voltage Switchgear and Systems
Catalog 1995/1996
Siemens Drives and Standard Products
Order No.: E20002-K1002-A101-A6

/1/

Richtlinie 89/392/EWG (Maschinenrichtlinie) Bundesanzeiger Verlag, 1993.

/2/

Positionspapier des AK 226.03 im DKE: Sicherheitsgerichtete Funktionen elektrischer Antriebssysteme in Maschinen.

/3/

Schaefer, M./Umbreit, M.: Antriebssysteme und CNC-Steuerungen mit integrierter Sicherheit, BIA-Report Nr. 4/97.

/4/

Kategorien für sicherheitsbezogene Steuerungen nach EN 954-1, BIA-Report 6/97.

/5/

ZH1/419. Prüf- und Zertifizierungsordnung der Prüf- und Zertifizierungsstellen im BG-Prüfzert. (Prüf- und Zertifizierungsordnung), Ausgabe 10/97.

/6/

Reinert, D./Schaefer, M./Umbreit, M.: Antriebe und CNC-Steuerungen mit integrierter Sicherheit (Antriebe und CNC-Steuerungen), in: ETZ-Heft 11/98.

/7/

Johannknecht, A./Warlich, H.-J.: Maschinenschutz in Europa – BG (Maschinenschutz).

/SHB/

Safety Integrated: Safety Integrated: The Safety System for Industry,
Application Manual, 4th Edition
Order No.: 6ZB5 000-0AA02-0BA0

Documentation

An overview of publications that is updated monthly is provided in a number of languages in the Internet at:

<http://www.siemens.com/motioncontrol>

Follow menu items → "Support" → "Technical Documentation" → "Overview of Documents" or "DOConWEB".

A.4 Abbreviations

AB	Output byte
AS1/AS2	Starting inhibit ½ (terminals on 611D performance control module)
ASUB	Asynchronous subroutine
ASIC	Application Specific Integrated Circuit (semiconductor module developed for special applications)
BAG	Mode group
BAG–STOP	Stop in corresponding mode group
β	Susceptibility to common cause failure
BG	Berufsgenossenschaft (Trade Association)
BGIA	Berufsgenossenschaftliches Institut für Arbeitssicherheit (German Institute for Occupational Safety)
BiCo	Binector–Connector (technology)
BOF	Bedienoberfläche
CCF	Common Cause Failure
CFG	Configuration telegram
CPU	Central Processing Unit
CRC	Cyclic Redundancy Check
CU	Control Unit
DB	Data block
DC	Diagnostic Coverage
DDS	DRIVE DATA SET
DI	Digital Input
DKE–AK	German Electrotechnical Working Committee
DL	Data Left
DMP	Distributed machine I/Os
DMS	Direct Measuring System
DO	Digital Output
DP	Distributed I/O
DPM	DP master
DPR	Dual Port RAM
DR	Data Right
DW	Data Word

ENDAT	Encoder Data (interface for absolute encoder)
EQN/ERN	Part of an order code for absolute/incremental encoders made by Heidenhain
ESD	Electro Static Discharge
ESR	Extended Stop and Retract
F-...	Failsafe-...
F-DI	Failsafe input module
F-DO	Failsafe output module
FD	Feedrate Drive
FOC	Force control, travel with limited torque/force
FV	Failsafe Values
FXS	Fixed stop, travel to fixed stop
HHU	Handheld unit
HMS	High-resolution Measuring System
HW	Hardware
I/RF	Infeed/Regenerative Feedback Unit
IBN	Start-up
IEC	International Electrotechnical Commission
IMP	Pulse cancellation
IMS	Indirect Measuring System
IPO	Interpolator
IS	Interface signal
KDV	Crosswise data comparison
λ	failure rate
LIFTFAST	Fast retraction from contour
LSB	Least Significant Bit
MAKSIP	Maschinen-Koordination-System-Istposition [Machine Coordinate System Actual Position]
MD	Machine Data or Marker Doubleword
MDD	Machine Data Dialog
MDIR	Machinery Directive
Mixed-IO	I/O module with analog and digital signals
MLFB	Machine-readable product designation

A.4 Abbreviations

MMC	Man Machine Communication (operator interface for man–machine communication)
MSB	Most Significant Bit
MSD	Main Spindle Drive
MT	Machine Tool
MTTF _d	mean time to dangerous failure
NC	Numerical Control
NCK	NC Kernel
NE	Line infeed module
OA	Operator Acknowledge
OB	Organization block
OP	Operator Panel
PFH _D	probability of a dangerous failure per hour
PL	Performance Level
PLC	Programmable logic controller
PM E–F	Power Module Electronic Failsafe
PS	Power supply
PSC	PROFIsafe cycle
QVK	Peer–to–peer data transfer
R	Gear Ratio
RPM	Revolutions Per Minute
SA–Link	Sensor–actuator–link
SBC	Safe Brake Control
SBH	Safe operating stop
SBM	Safe Brake Management
SBR	Safe braking ramp
SBT	Safe Brake Test
SE	Safe Limit Switch
SG	Safely–reduced speed
SGA	Safely–relevant outputs
SGE	Safely–relevant inputs
SH	Safe standstill
SI	SINUMERIK Safety Integrated [®]
SIL	Safety Integrity Level

SILCL	SIL claim limit
SK	Softkey
SN	Safe cams
SPL	Safe Programmable Logic
SSFK	Leadscrew Error Compensation
STOP	Stop response:
A, B, C, D, E, F	In the event of a fault, the system reacts depending on the configured STOP response
SW	Software
T1	Lifetime
T2	Diagnostic test interval
TCP	Tool Center Point
TEA	Testing Data Active
UG	Lower limit
UL	Upper limit

A.5 Terms

Actuator

Converter that converts electrical signals into mechanical or other non-electrical quantities.

Category

Used in EN 954-1 to "Classify safety-related parts of control with reference to their immunity to faults and their behavior when a fault condition exists due to the structural arrangement of the parts/components and/or their reliability".

Channel

Element or group of elements that execute function(s) independently of one another.

2-channel structure

This is a structure that is used to achieve fault tolerance.

For instance, a 2-channel protective door control can only be achieved if at least two enable circuits are available and the main circuit is redundantly shut down or a sensor (e.g. Emergency Stop switch) with two contacts is interrogated and these are separately routed to the evaluation unit.

Fail-safe

The ability of a control system, also when faults occur (failure), to maintain a safe condition of the controlled equipment (e.g. machine, process), or to bring the equipment into a safe condition.

Failure/fault

Failure

A piece of equipment or device can no longer execute the demanded function.

Fault

Undesirable condition of a piece of equipment or a device, characterized by the fact that it is unable to execute the demanded function.

Note: "Failure" is an event and "fault" is a condition.

Fault tolerance

Fault tolerance N means that a piece of equipment can still execute the required task even if N faults are present. For N+1 faults, the equipment can no longer execute the required function.

Redundancy

Availability of more than the necessary equipment to execute the required tasks.

Requirement Class

Measure for the safety-related performance of control equipment, defined in DIN V 19250 and DIN VDE 0801.

Risk

Combination of the probability of damage occurring and the extent of the damage.

Safety

Freedom from an unacceptable risk.

Functional safety

The part of the safety of a piece of equipment (e.g. machine, plant) that depends on the correct function.

Safety function

Function, (e.g. of a machine or a control) whose failure can increase the risk/risks.

Safety functions of controls (EN 954)

A function "initiated by an input signal and processed by the safety-related parts of controls, that allows the machine (as system) to reach a safe condition".

Safety goal

To keep the potential hazards for personnel and the environment as low as possible without restricting more than absolutely necessary, industrial production, the use of machines or the manufacture of chemical products.

Safety Integrity Level (SIL)

Measure, defined in IEC 61508, for the safety-related performance of an electrical or electronic control device.

Stop Category

Term used in EN 60204-1 to designate three different stopping functions.

Stopping

Function that is intended to avoid or reduce impending or existing hazards for personnel, damage to the machine or the execution of work. This has priority over all operating modes.

Index

Symbols

\$A_STOPESEI, 5-110
\$MN_INFO_PROFISAFE_CYCLE_TIME,
5-240
\$VA_STOPSI, 5-110

A

Absolute encoders, 4-73
Acceptance test, 7-354, 7-359
Acceptance test support, 7-369
Acknowledge/save monitoring data, 7-354
Actual value and measuring circuit assignment,
7-353
Actual value synchronization, 4-84
Actuator, A-662
Adjusting the motor encoder, 4-75
Alarms
for 840D, 8-391
for 611digital, 8-447
Assigning priorities to alarms, 8-465
Axes, vertical, 9-475
Axial checksum, 5-249
Axis not referenced, 4-78
Axis referenced (homed), 4-78
Axis safely referenced, 4-79

B

Basic Standards, 1-28
Brake test, 10-602

C

Calibrating the machine, 4-75
Cam signals, 5-155
Cam synchronization, 5-157
Enabled for 840D, 6-271
Category, A-662
Changing SI data, 7-357
Changing-over the speed limit values, 5-140
Channel, A-662
Circuit examples, 10-489
Clock cycle overruns, 5-240
CNC controls, 1-43
Coding of the input assignment, 6-288
Coding of the output assignment, 6-294

Commissioning 840D
First commissioning, 7-352
Series commissioning, 7-356
Communications, NCK and PLC-SPL, 5-215
Comparison clock cycle, for 840D, 6-262,
6-268
Configuration for 840D, 7-350
Connecting-up the drives, 10-512, 10-556
Control category 3, A-655
Crosswise data comparison, 4-70, 5-187
Cut-off frequency, 5-137

D

D/A converter output, 7-359
Data, changing, 7-357
Defining the cam positions, 5-156
Delete password, 7-355
Different channel run times, 5-178
Digital PLC inputs/outputs for 840D, 5-182
Direct measuring system, 4-74
Diverse structure, 1-45
DMP compact modules, 5-179
DMS, 4-74
Door safety contactor, 10-561
Downloading standard motor data, 6-306
Drive with slip, 10-640

E

Electrical safety, 1-35
EMC Directive, 1-27
EMERGENCY STOP, 10-516, 10-557
Enable, functions for 840D, 6-271
Enable option, for 840D, 7-352
Enabling functions, 4-87
Encoder limit frequency, 5-137
Encoder limit frequency, parameterizable,
5-137
Encoder type combinations, 4-73
Encoder types, 4-73
2-encoder system, 4-74
Performance closed-loop control module,
4-73
Engineering, 10-487
Enter the monitoring clock cycle, for 840D,
7-352
Error code, Detailed fault coding, 5-112

ESR, 5-109
 ET200S PROFIsafe components, Parameterization, 10-567
 ET200S PROFIsafe module, Connecting-up, 10-567
 EU Directives, 1-27
 External STOPS, Machine data, 5-125

F

F master, 5-243
 NCK, 5-238
 PLC, 5-250
 F net data filter, 5-244, 5-247
 Fail-safe, A-662
 Failure/fault, A-662
 Fault tolerance, A-662
 Force due to weight, 6-307
 Forced checking procedure, 5-224
 Forced checking procedure, safety relay, 5-206

G

Gantry axis, 9-474
 Group Standards, 1-29

I

Incremental encoders, 4-73
 Initialization, Safety relay, 5-203
 Interface signals, 6-338
 to the drive, 6-339
 from the drive, 6-344
 Internal pulse cancellation, 5-94

L

Limiting the speed setpoint, 9-469
 Linear motors, 1-44
 Local inputs on the NCU, 6-289, 6-295
 Logbook, 7-354

M

Machine data for 611digital, Description, 6-307
 Machine data for 840D
 Description, 6-259
 Overview, 6-255
 Machinery Directive, A-655
 Measuring system changeover, 9-474

Module type, 5-249
 Modulo display, 5-158
 Modulo value for SN, 6-272
 Monitoring channel, 5-173
 Monitoring clock cycle, 4-69
 for 611digital, 6-307
 for 840D, 6-261
 Monitoring functions – standard, 3-51
 Multiple assignment, 5-181
 Multiple distribution, 5-180

N

NC/PLC interface, 6-338
 NCK SGEs/SGAs, 5-178
 NCK-RESET for 840D, 7-350
 NCK-SPL programming, 5-191
 NCU onboard I/Os, 5-199
 NCU terminal block, 5-179
 NCU-local inputs/outputs, 5-199

O

OEM applications, 9-476
 Override factor, safely-reduced speed, 5-143, 6-341

P

Parking an axis, 9-475
 Parking an axis with absolute reference, 9-475
 Performance closed-loop control module, 5-126
 PLC SGEs/SGAs, 5-178
 Powering-up, 4-89
 Product Standards, 1-29
 Profibus connection, 10-577
 PROFIBUS-DP, 5-228
 PROFIsafe clock cycle overruns, 5-240
 PROFIsafe, system prerequisites, 3-59
 PROG_EVENT mechanism, 5-193
 PROG_EVENT.SPF, 5-194
 Protective door, 10-496
 Protective door interlocking, 10-535, 10-560
 Protective mechanisms, 5-192
 Pulse cancellation, 5-98
 Internal, 5-94

R

Redundancy, A-662
 Reference point reached, 4-78
 Replacing a motor, 10-626
 Replacing an encoder, 10-626
 Requirement Class, A-662
 Risk, A-663
 Risk analysis, 1-35
 Risk assessment, 1-35
 Rotary axis, 6-271, 6-308

- Cam actual value range, 5-158
- Endlessly turning, 5-158
- Modulo display, 5-158
- Safe software cams, 5-158

S

Safe brake test (SBT), 10-602
 Safe braking ramp, 5-167
 Safe cams, 5-155
 Safe limit switches, 5-151
 Safe operating stop, 5-129

- De-selection, 5-132
- Features, 5-129
- Prerequisites, 5-130
- Selection, 5-130

 Safe operating stop, test, 7-364
 Safe signal processing, 5-175
 Safe software cam, test, 7-365
 Safe software cams

- Defining the cam positions, 5-156
- Features, 5-155
- Hysteresis, 5-157
- Machine data, 5-165
- Output assignment, 5-158
- Prerequisites, 5-155
- Special case, 5-156
- Synchronization, 5-157
- Tolerance, 5-156

 Safe software limit switch, test, 7-365
 Safe software limit switches

- Configurable stop responses, 5-152
- Features, 5-151
- Limit values, 5-151
- Machine data, 5-154
- Prerequisites, 5-152

 Safe standstill Prerequisites, 5-127
 Safe stop, 5-126

- Features, 5-127
- Selecting/de-selecting, 5-127

 Safely-reduced speed, 5-136

- Changing-over the limit values, 5-140
- Configured stop responses, 5-141
- Features, 5-136
- Override for, 5-143, 6-341
- Prerequisites, 5-136
- Selection, 5-138

 Safely-reduced speed, test, 7-365
 Safety, A-663
 Safety function, A-663
 Safety goal, A-663
 Safety Integrity Level (SIL), A-663
 Safety relay, 5-202
 Safety relay, test, 5-206
 Save data, 7-355
 Save standstill position, 4-80
 Saved standstill position, 4-80
 Saving boot files, for 840D, 7-351
 SBH, 5-129
 SBR, 5-167
 SE, 5-151
 Selecting speed limit values, 5-139
 Sensor/actuator connection, 5-172
 Series commissioning, 7-356
 Service display, 5-175
 Service display for 840D, 8-376
 Servo trace, 7-359, 8-383
 Set axis monitor, 7-353
 Setting the password, 7-352
 SG, 5-136
 SG override, 5-143, 6-341
 SG specific STOPS, 5-143
 SGA, SBH active, 5-132
 SGE/SGA

- How many are required as a minimum?, 5-177
- Machine data, 5-184
- Signal run times, 5-178

 SGE/SGA assignment, for 840D, 7-353
 SGE/SGA test, 7-364
 SGEs, Standstill via STOP, 5-116
 SH, 5-126
 Shutdown path of the drive CPU, 5-93
 Shutdown path of the NCK-CPU, 5-94
 Shutdown paths, 5-92

- Prerequisites, 5-96
- Stop responses, 5-103
- Test, 5-96

 Shutdown paths for a dual-axis module, 5-100
 Shutdown paths for several axes without SPL, 5-100

- SI relay, 5-202
- SI with ESR, 10-643
- SIRELAY, 5-205
- Slip, between motor and load, 10-640
- Slip for 2–encoder system, 4-84
- SN, 5-155
- Softkey
 - Acknowledge SI data, 7-351
 - Copy SI data, 7-351
- Speed setpoint, 9-469
- Speed/standstill monitoring, 1-43
- SPL, Coupling to the I/O, 5-199
- SPL data on the PLC side, 5-212
- SPL start without axial safety enable, 5-187
- SPL system errors, 5-188
- SPL–SGA, PROFIsafe, 5-248
- SPL–SGE, PROFIsafe, 5-245
- Standstill tolerance, 5-129
- Standstill via SGEs, 5-116
- Start SPL, 5-196
- STOP A, Description, 5-106
- STOP B, Description, 5-107
- STOP C, Description, 5-108
- Stop Category, A-663
- STOP D, Description, 5-109
- STOP E, Description, 5-109
- STOP F, Description, 5-111
- Stop response, SG specific, 5-143
- Stop responses
 - Assignment table, 5-105
 - Machine data, 5-169
 - Priority, 5-105
 - Sequence, 5-106
- Stop responses, configurable, 5-105

- Stopping, A-663
- Sub–slot, 5-243, 5-246
- Synchronizing cam signals
 - Description, 5-157
 - Enable, 5-157
- System variable \$VA_IS, 6-328
- System variables, 5-209
- System variables \$A_XFAULTSI,
\$VA_XFAULTSI, 6-329

T

- Test stop, 10-522, 10-559
 - for external STOPs, 5-120, 6-342
 - Instant in time, 5-96
 - Sequence, 5-97
- Testing the external pulse cancellation, 5-98
- Timing when the cam position is passed, 5-160
- Tolerance for SN, 5-156
- Troubleshooting, for 840D, 8-375
- Two–channel structure, 1-45
- Two–encoder system, 4-74

U

- User agreement, 4-76, 7-354
- User agreement Interlock, 4-77
- User agreement, saved, 4-79

V

- Velocities and speeds, 5-137
- Vertical axes, 9-475

To
 SIEMENS AG
 A&D MC MS
 Postfach 3180
 D-91050 Erlangen
 (Tel. +49 (0) 180 / 5050 222 [Hotline]
 Fax +49 (0) 9131 / 98 – 63315 [Documentation]
 e-mail: mailto:motioncontrol.docu@siemens.com)

<p>From</p> <p>Name _____</p> <p>Company/Dept. _____</p> <p>Address _____</p> <p>Postal code: _____ City: _____</p> <p>Phone: _____ / _____</p> <p>Telefax: _____ / _____</p>	<p>Suggestions</p> <p>Corrections</p> <p>For Publication/Manual:</p> <p>SINUMERIK 840D/ SIMODRIVE 611 digital SINUMERIK Safety Integrated (FBSI)</p> <p>Order No. 6FC5 297-7AB80-0BP1</p> <p>Edition: 03.2006</p> <p>Should you come across any printing errors when reading this publication, please notify us on this sheet. Suggestions for improvement are also welcome.</p>
--	--

Suggestions and/or corrections